

J. ASTON.
Breech-Loading Fire-Arm.

No. 201,216.

Patented March 12, 1878.

FIG. 1

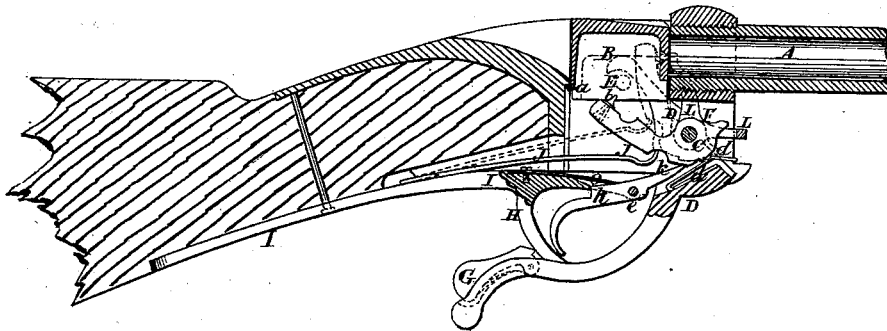

FIG. 2

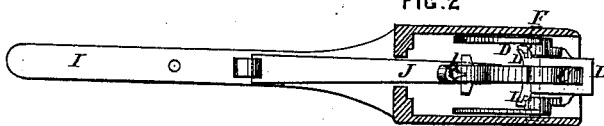

FIG. 3

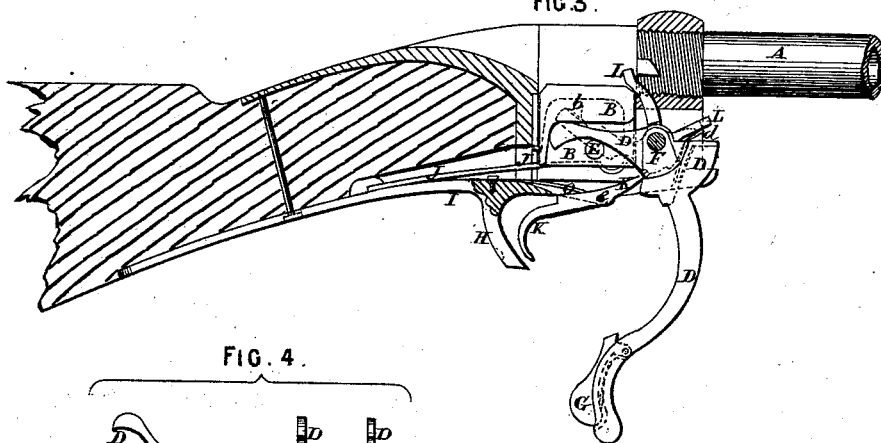

FIG. 4

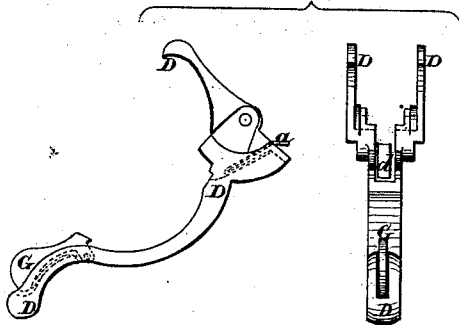

FIG. 6

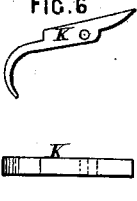

FIG. 5

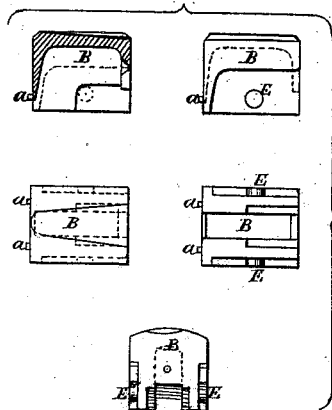

FIG. 7

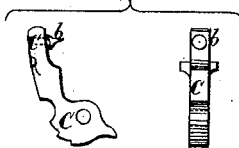

FIG. 7^a

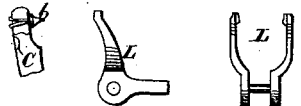
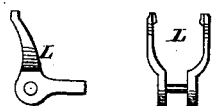

FIG. 8



Witnesses
C. Wells
M. C. Bial

Inventor
James Aston

UNITED STATES PATENT OFFICE.

JAMES ASTON, OF HYTHE, ENGLAND.

IMPROVEMENT IN BREECH-LOADING FIRE-ARMS.

Specification forming part of Letters Patent No. **201,216**, dated March 12, 1878; application filed November 26, 1877; patented in England, February 19, 1876.

To all whom it may concern:

Be it known that I, JAMES ASTON, of Hythe, in the county of Kent, England, have invented new and useful Improvements in Breech-Loading Fire-Arms, which improvements are fully set forth in the following specification, reference being had to the accompanying drawings—that is to say:

This invention refers to the construction of the action of fire-arms, whereby the arrangement is greatly simplified, and a reduction effected in the number of parts and cost of production.

My invention consists in an improved construction and arrangement of the breech-block, hammer, and trigger-guard of breech-loading fire-arms; and also in the combination, with the trigger-guard and breech-block operator, of an improved shell-extractor.

And, in order that my said invention may be properly understood, I will now proceed to describe the same with reference to the accompanying sheet of drawings, and to the letters and figures marked thereon.

Figure 1 is a vertical section of my improved breech-loading action shown applied to a gun-stock. Fig. 2 is a sectional plan of part of the same, while Fig. 3 illustrates the position of the parts of the action when the breech-block has been lowered for the introduction of a fresh cartridge into the barrel A.

The interior of the breech-block B is fashioned so as to allow of the stroke of the hammer C, and each of its sides (where it is embraced by the double-claw lever D) is recessed, so as to present a shoulder, against which the upper part of the double-claw lever D bears and acts, so as to raise the breech-block. To provide for its depression by the same means projecting studs E are arranged on each side, so as to be acted upon by the double-claw lever on its downward stroke.

To steady the breech-block in its movements, two small projections or snugs, *a*, are provided at the back, and arranged to slide in a recess or slot formed for their reception. The front part of the block has a hole, through which the needle *b* on the hammer C passes to impinge on the cartridge. Several detail views of the breech-block are shown at Fig. 5 of the drawings.

The combined double-claw lever and trigger-guard D (the construction of which will be better understood by reference to the detailed views at Fig. 4) is centered upon the stud F. The upper part or claw-lever proper is forked, so as to embrace the breech-block, and the curved trigger-guard portion is provided with a sneek, G, upheld by a spring, and arranged so that when the guard is closed—that is to say, when in the position shown at Fig. 1—the sneek G will take into a recess in a horn or projection, H, formed on the trigger-plate I, and which abuts upon the guard. The combined claw-lever and trigger-guard D is thus locked in position, and can only be released by pressing upon the sneek G, so as to lift its toe out of the recess in the projection H. A flat spring, *d*, is secured between the arms of the claw-lever, and a projection or toe is formed upon the hammer C opposite to the said flat spring, so that when the firing action takes place the percussive action of the hammer is softened by the said toe coming into contact with the spring, whereby breakage is avoided.

In certain cases the spring *d* may be further utilized to cause the action to rebound to half-cock.

The hammer C, detail views of which are shown at Fig. 7, is also centered upon the stud F, and I propose to make the needle or striker point *b* easily removable by splitting the shank which passes through the hammer-head, and making the hole tapered, so that when the split shank is compressed and passed through the hammer-head it expands and fills the enlarged part of the hole, and is thus prevented from coming out.

The shank may be made round, square, triangular, or polygonal; but I prefer that it should be oval.

A modification is shown in Fig. 7^a. The split shanks are provided at each side with a projection, so that when the shanks are compressed and passed through the hammer-head the shanks expand, and the projections catch on the back part of the hammer-head. These projections are to be pressed together when it is desired to remove the striker-point. The hammer is actuated by a flat spring, J, and it is retained at full or half cock by means of the trigger K in the ordinary manner.

The extractor L, the duty of which is to eject the spent cartridge from the barrel, is of the form most clearly shown at Fig. 8. It is also centered upon the main stud F, and is actuated by the same movement which depresses the breech-block and cocks the hammer, for, in swinging round the movable trigger-guard into the position shown at Fig. 3, the tail of the spring *d* comes into contact with the extractor, and throws it into the position shown at Fig. 3, thereby jerking out the exploded cartridge, and leaving the barrel ready to receive a fresh case. The extractor is replaced in the position shown at Fig. 1 by the action of closing the trigger-guard D.

The trigger K, which is of the ordinary construction, and which is shown more fully at Fig. 6, is centered on the trigger-plate I by the pin or stud *e*, and is kept up against the bottom of the hammer C by a flat spring, *o*.

The mode of operation is as follows: Supposing the fire-arm, as shown at Fig. 1, to be loaded; then, by pulling the trigger K, the hammer C is released, and thrown by the pressure of the flat spring J into the position indicated by dotted lines. The needle-point *b*, by smiting on the end of the cartridge, causes it to explode and expel the projectile.

To reload, the sneck G is depressed and the trigger-guard D thrown into the position shown at Fig. 3, by which movement three operations are performed—that is to say, the

breech-block B is lowered, the hammer C is recocked, and the extractor L caused to expel the spent cartridge, all in the manner hereinbefore described and shown. A fresh cartridge having been introduced into the barrel A, the trigger-guard is replaced in the position shown in Fig. 1, and the piece is again ready for use.

Having now particularly described my said invention, and the mode of carrying the same into practical effect, I claim and desire to be secured to me—

1. The combination, with the pivoted trigger-guard or breech-block operator, of the shell-extractor L and spring *d*, substantially as and for the purpose set forth.

2. The combination of the breech-block B, reciprocating in a right line, and provided with lugs *a*, fitting in suitable guides in the breech-block passage, the swinging forked trigger-guard D, and the pivoted hammer C, swinging between the forwardly-separated side walls of said breech-block, substantially as described.

JAMES ASTON.

Witnesses:

G. H. ROBINSON,

*Clerk to Messrs. Collette, 23 Lincoln's
Inn Fields.*

WILMER M. HARRIS,

17 Gracechurch street, London, E. C.