

A. CAMPBELL.
Printing-Press.

No. 201,226.

Patented March 12, 1878.

Fig. 2.

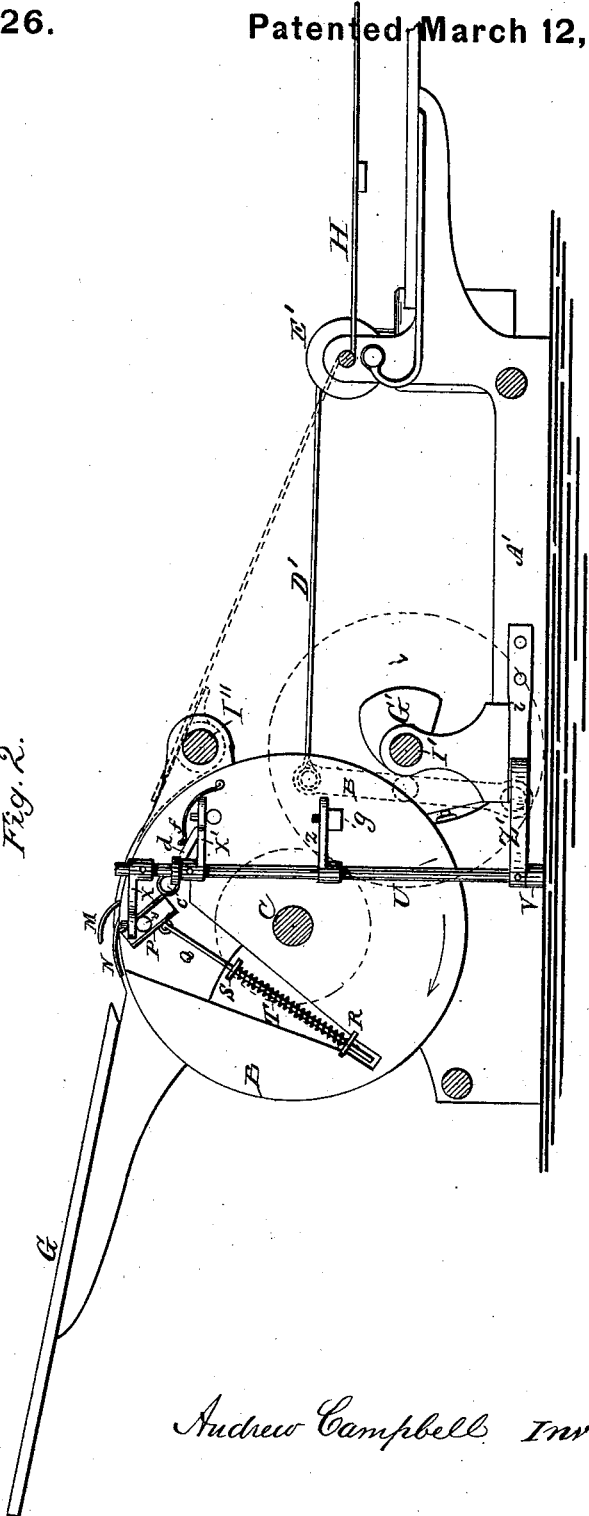

Attest:
 John Tyler.
 Geo. J. Bonner.

Andrew Campbell Inventor

By Wm. C. Whitcomb
 Atty.

A. CAMPBELL.
Printing-Press.

No. 201,226.

Patented March 12, 1878.

Fig. 3.

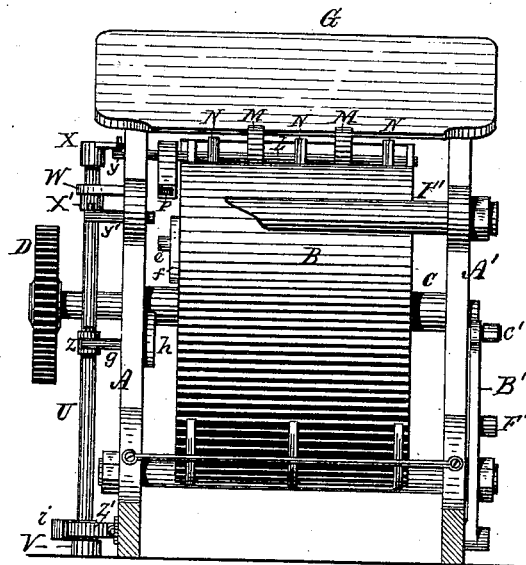

Fig. 4.

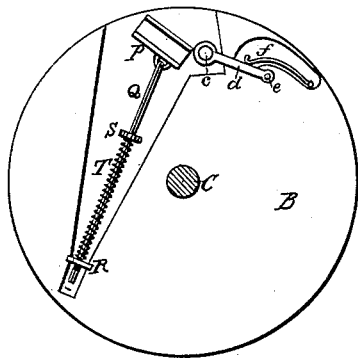
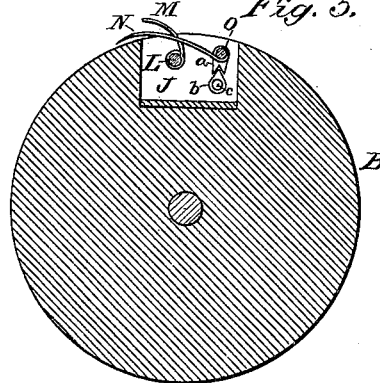

Fig. 5.



Attest
 John Tyler.
 Geo. J. Bonner.

Inventor:
 Andrew Campbell

by American Att'y.

UNITED STATES PATENT OFFICE.

ANDREW CAMPBELL, OF BROOKLYN, NEW YORK.

IMPROVEMENT IN PRINTING-PRESSES.

Specification forming part of Letters Patent No. **201,226**, dated March 12, 1878; application filed July 27, 1877; patented in England, January 18, 1872.

To all whom it may concern:

Be it known that I, ANDREW CAMPBELL, of Brooklyn, in the county of Kings and State of New York, have invented certain new and useful Improvements in Printing-Presses; and I do hereby declare that the following is a full and exact description thereof, reference being had to the accompanying drawings, making a part of this specification.

My invention relates to certain improvements in that class of printing-presses in which the sheet, after it is printed, instead of being discharged at the rear of the machine is carried up on the cylinder, and is discharged after it has passed the summit of the same and commenced its descent on the front side of the machine.

The object of my invention is to deliver the sheet from the front of the cylinder direct to the fly without the use of tapes, and with the clean side next to the fly, whereby the smutting of the sheet is avoided, as shown and described in Letters Patent of Great Britain, granted to me in the year 1872, and numbered 169.

With these objects in view, my invention consists in the combination, with the cylinder of a press such as described, of sheet-lifters and a fly so arranged and operating that the sheet, as it is released from the grippers, will have its edge elevated and be discharged onto the fingers of the fly with the clean side next to the fly, and without the use of other intervening appliances, such as tapes, &c., as will be hereinafter more fully set forth.

My invention also consists in the construction and arrangement of the particular devices employed, as will be hereinafter more fully set forth.

To enable those skilled to fully understand my invention, I will proceed to describe the same, referring by letters to the accompanying drawings, in which—

Figure 1 is a top or plan view of a machine embodying my invention. Fig. 2 is a side elevation, with the driving-gearing and side frame removed. Fig. 3 is a front-end view, with a portion of the frame and the fly cut away. Fig. 4 is an end view of the cylinder; and Fig. 5 is a central cross-section of the cylinder and griper and lifting-finger shafts.

Like letters of reference refer to like parts in the several figures.

A A' are the side frames of the machine, bolted together in the usual manner. B is the impression-cylinder, mounted upon a shaft, C, on the one end of which is secured a pinion, D, meshing with the driving-gear E, the inner disk-face of which has formed thereon or secured thereto a cam or double incline, F, for the purpose presently explained. G is the feed-table; H, the fly, and I the receiving-table.

The cylinder is formed with a longitudinal slot or recess, J, with end plates *k*, which form a portion of the cylinder-heads, and in which the griper and lifting-finger shafts have their bearings.

L is the griper-shaft, and M the grippers, secured thereto. N are the lifting-fingers, and O the shaft to which they are attached.

The griper-shaft L extends a short distance through one head of the cylinder, and is provided with a griper-cam, P, one end of which is pivoted to a vibrating rod, Q, the lower end of which reciprocates within a bearing or guide-plate, R, between which and a collar, S, on the rod Q is located a spiral spring, T, which serves to hold the griper-shaft in either of its extreme positions when rocked by the cam, as presently explained.

The rod Q and its guide-plate, &c., are located within a V-shaped recess in the head of the cylinder, and within which the rod is free to vibrate.

The shaft O of the lifting-fingers N is furnished at one end with a collar, *a*, the under side of which projects downwardly, and is bifurcated or grooved, as seen at Fig. 5, to receive a correspondingly-shaped finger, *b*, secured to a short rock-shaft, *c*, to the outer end of which is secured a crank, *d*, with wrist-pin *e* at the free end. *f* is a spring, one end of which is secured to the head of the cylinder, and the other bearing upon the edge of the crank-arm *d*, the effect of which is to hold the fingers N down upon the cylinder.

U is a vertical rock-shaft, mounted in a step-bearing, V, at its lower end, and passing through a bracket-bearing, W, near the top, both of which project from the side frame A. At the top end of this shaft, above and below the bracket W, are keyed two arms, X X', the outer ends of which are slotted and fit over vertical pins upon two short reciprocating bolts, *y y'*. Near the center of the shaft U is another arm, *z*, similar to the arms X X', and

connected to the outer end of a square bolt, *g*, adapted to reciprocate through the side frame A, and furnished on its inner end with a cam, *h*. To the lower end of the shaft U is secured another arm, Z', the end of which is slightly curved, and which is forced outwardly against the driving-gear by a spring, *i*.

To the side frame A', and near the base thereof, is pivoted a vibrating lever, B', provided at its upper end with a short wrist-pin, C', which receives one end of a strap, D', the other end of which is secured to a fast pulley, E', secured to the rock-shaft of the fly. Just below the center of the lever B' is another short pin, F', which is periodically struck by a cam, G', secured to the end of the driving-shaft I', the effect of which is to cause the arm B' to vibrate during every revolution of the drive-shaft, and, pulling the strap D', causes the fly-fingers to approach the cylinder at the time the sheet is to be delivered therefrom, the fly being returned to deposit the sheet by means of a strap, H', and weight K', secured to a second fast pulley, L', on the fly-shaft.

I have shown the fly-fingers as resting on the front upper bolt I'', that secures the side frames in position, and so arranged that the ends of the fingers will come nearly in contact with the surface of the cylinder and immediately under the edge of the sheet as it is raised by the sheet-lifters. Of course other means may be employed for holding the fly-fingers at exactly the proper position to receive the raised sheet—such, for instance, as a stop on the fly-shaft or the regulated throw of the lever B'; and in lieu of the fingers taking the sheet direct from the cylinder, fixed strippers may be secured to the bar I'', and the fly-fingers, resting upon said bar, take the sheets as they are stripped by the strippers, as clearly shown in dotted lines at Fig. 2 of the drawing.

Having described the construction of my improved machine, I will now describe its operation. As the sheet is fed from the table G the grippers M are slightly open, as seen in all the figures of the drawings, and the lower arm Z' of the vertical shaft U is forced out to its extreme limit by the spring *i* against the face of the drive-wheel E, which has rocked the said shaft so as to force inwardly the bolt *y*, which has entered the griper-cam P. A continuation of the rotation in the direction of the arrow, Fig. 2, causes the cam P and its shaft to rotate and force the grippers against the cylinder, binding the sheet thereto, the spring-rod Q holding the grippers in such position until released again by a positive action. The continuation of the rotation of the cylinder carries the sheet around to receive the impression, and just before the gripped edge of the sheet reaches the point where the grippers took hold of it, one of the inclines F on the drive-gear comes in contact with the curved end of the arm Z', and, forcing it inwardly, rocks the shaft U, so as to draw the bolt *y* and allow the cam P to pass unmolested. As the bolt *y* is drawn, the bolt

y' is obviously forced inwardly toward the head of the cylinder, as is also the square bolt *g* with its cam *h*. As the cylinder proceeds, the cam P is entered by the bolt *y'*, and the griper-shaft rocked to open the grippers, (the spring-bar Q holding them open until bolt *y* again acts to close them,) and at or about the same instant of time the wrist-pin *e* on the crank-arm *d* strikes the cam on the square bolt *g*, and forces the end of the arm toward the periphery of the cylinder, and, through the medium of the finger *b* on short shaft *c*, and bifurcated collar *a* on the finger-shaft, causes the latter to rock and slightly lift the fingers, which raise the edge of the sheet so that it will pass on top of the fly-fingers, which have been brought in tangential relation to the cylinder through the vibrating arm B' and its connection with the drive-shaft and fly-shaft, as heretofore described. It will be readily understood that by this operation the sheet is delivered to the fly with the clean side against the fly, or with its printed side uppermost. At the time of the discharge of the sheet from the cylinder the fly and cylinder are in such relative position, as seen at Fig. 2, that both centrifugal force and gravity combine to freely slide the sheet completely onto the fly, which is thrown back (while the cylinder continues its revolution preparatory to receiving another sheet) by the action of the weight and strap, the cam G' having in the meantime moved away from the vibrating arm B'.

I am aware that it is old to rotate the impression-cylinder to bring the sheet or card in position to be printed, and to then reverse the cylinder and deliver the sheet, tail first, directly to a fly, and I do not wish to be understood as laying claim to such construction; but

Having thus fully described my invention, what I claim as new, and desire to secure by Letters Patent, is—

1. In a printing-press having a continuously-rotating impression-cylinder, the combination, with the cylinder, of a fly arranged substantially as described, so that the sheet will be stripped by the fingers of the fly from the cylinder, after the impression, head first, and with the printed side up, substantially as and for the purposes described.
2. The combination of the sheet-lifters with the fly and impression-cylinder, substantially as hereinbefore set forth.
3. The combination, with the griper-shaft and cam, lifting-finger shaft, and crank-arm *d*, of the vertical rock-shaft U, bolts *y y' g*, spring *i*, and double incline F, substantially as and for the purposes described.

Witness my hand this 29th day of June, 1877.

ANDREW CAMPBELL.

Witnesses:

GEO. E. LLOYD,
J. L. BROWER.