

J. MILLER, Jr.
Gas-Regulator.

No. 201,270.

Patented March 12, 1878.

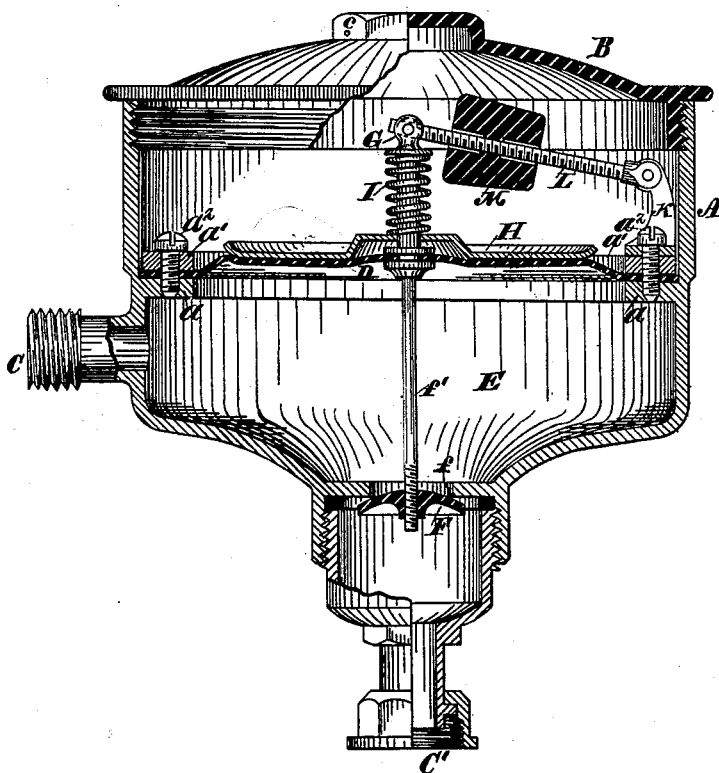

Fig. 1

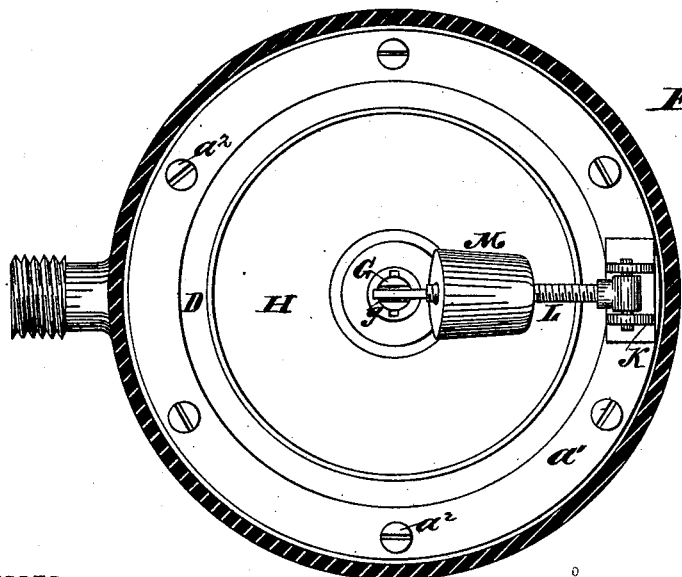

Fig. 2

WITNESSES:

Saml. J. Van Stavoren

Jos. B. Connolly

INVENTOR

John Miller Jr.

Jos. B. Connolly *By Connolly Bros.* ATTORNEYS.

UNITED STATES PATENT OFFICE.

JOHN MILLER, JR., OF PHILADELPHIA, PENNSYLVANIA.

IMPROVEMENT IN GAS-REGULATORS.

Specification forming part of Letters Patent No. 201,270, dated March 12, 1878; application filed November 13, 1877.

To all whom it may concern:

Be it known that I, JOHN MILLER, Jr., of Philadelphia, in the county of Philadelphia and State of Pennsylvania, have invented certain new and useful Improvements in Gas-Regulators; and I do hereby declare the following to be a full, clear, and exact description of the invention, such as will enable others skilled in the art to which it pertains to make and use it, reference being had to the accompanying drawings, which form part of this specification, in which—

Figure 1 is a longitudinal vertical section, and Fig. 2 is a horizontal section, of my invention.

My improvements have for their object to provide a gas-regulator which shall be more efficient in its operation, more durable, and less liable to get out of order than any device for the same purpose heretofore produced.

This invention has relation to gas-regulators; and consists in the novel construction, combination, and arrangement of parts hereinafter fully described and claimed.

Referring to the accompanying drawings, A designates the main shell or body of the regulator, having a removable top, B. C and C' are, respectively, the inlet and outlet passages for the gas, and *c* is an orifice in the top B for the admission and expulsion of air. D is a flexible diaphragm, located at or about the middle of the body A, and fastened on an internal annular flange, *a*, on said body by a ring, *a*¹, and screws *a*², as shown.

The diaphragm is composed of enameled leather, (or other equivalent material having an enameled surface similar to such leather,) which I have found to be impervious to hydrocarbon gas, and not subject to deleterious effects from said gas or its resultant vapors, as leather or other material not enameled is.

The enameled side of the leather is turned down—that is, the enameled side is underneath, and adjacent to the gas-chamber E, of which said diaphragm forms the top.

F is the valve, having its seat at *f*, and a stem, *f*', which passes through and projects some distance above the diaphragm D, ter-

minating in a threaded end, for receiving a nut, G.

H is a metallic plate or disk, which rests, as shown, on the diaphragm D, and I is a coiled spring, surrounding the stem *f*' between the nut G and disk H, and exerting pressure upon the latter.

K is a bifurcated standard, rigidly secured on the annular flange *a*, and L is a threaded rod, pivoted in the said standard and in the nut G, which is slotted at *g* for the reception of said rod. M is a weighted screw-nut fitted to the rod L, so as to be moved to and fro on the latter by turning.

Gas, being admitted from the meter through the inlet C, raises the diaphragm D, which expands or inflates against the plate or disk H. The disk H is thus elevated or slid upwardly on the stem *f*', compressing the spring I and drawing up the valve F against the seat *f*. The nut or weight M is now moved forward in the direction of the nut G sufficiently to load the valve F or depress it far enough away from its seat *f* to permit the gas to escape through the outlet C' to the service-pipe at the required pressure.

The rod L serves not only as a support for the weight M, but also as a steadying-bar for the valve-stem, and, through the latter and the disk H, for the diaphragm D, preventing the fluttering of the latter and the flickering of the light at the burner.

What I claim as my invention is—

In a gas-regulator, the combination, with the flexible diaphragm D and plate H, of the central valve-stem *f*' attached to the valve F, the spring I encircling said stem, the pivoted steadying-bar attached to the valve-stem, and the weight M, adjustable on said bar, as shown and set forth.

In testimony that I claim the foregoing I have hereunto set my hand this 19th day of October, 1877.

JOHN MILLER, JR.

Witnesses:

M. D. CONNOLLY,
SAM'L. J. VAN STAVOREN.