

G. VINCENT.  
Locomotive.

No. 201,308.

Patented March 12, 1878.

Fig. 1.

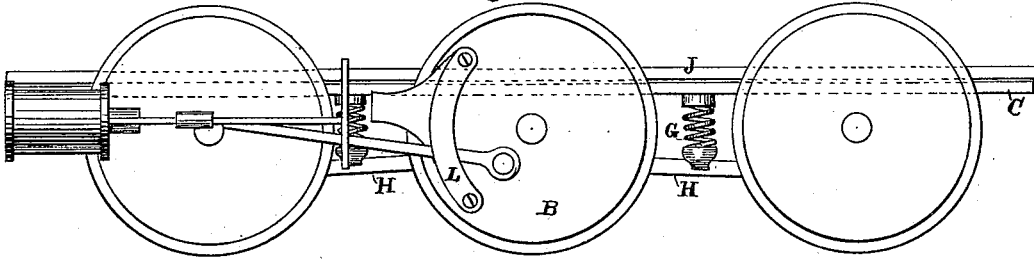

Fig. 2.

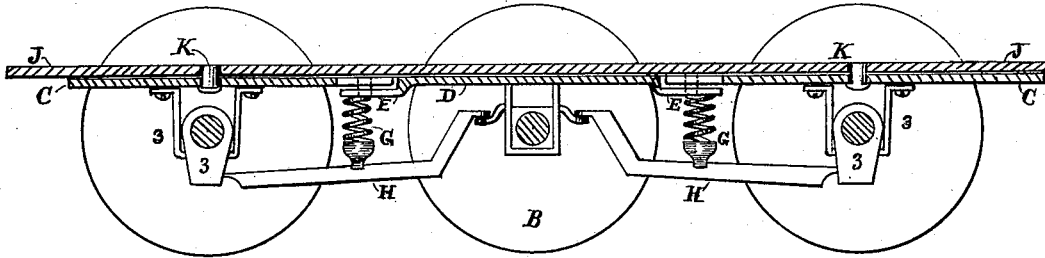
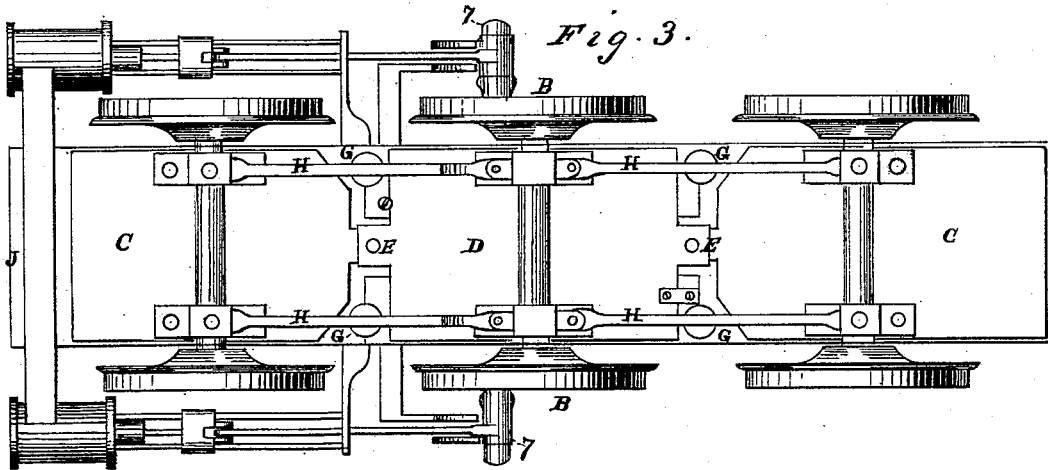

Fig. 3.



Witnesses

*Edw. Smith*  
*Chas. J. Shook*

Inventor

*George Vincent*

G. VINCENT.  
Locomotive.

No. 201,308.

Patented March 12, 1878.

Fig. 4.

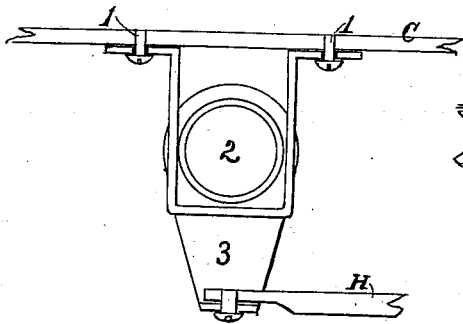

Fig. 5.

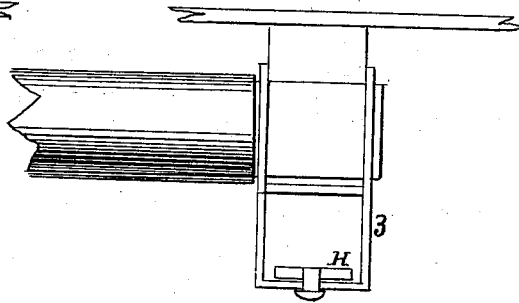

Fig. 6.

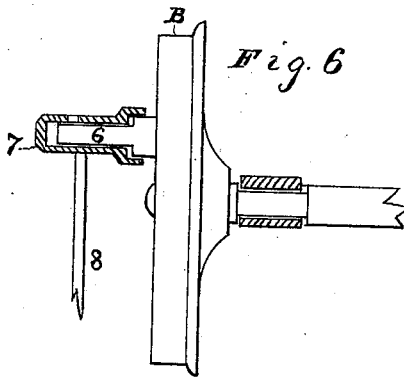
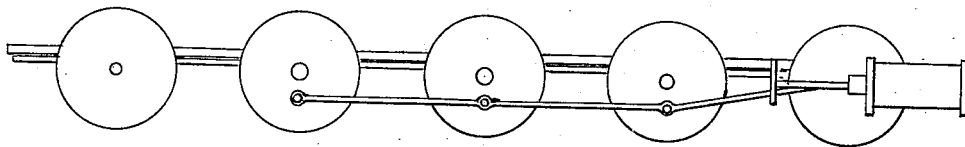

Fig. 7.



Witnesses .

*Edgworth*  
*Geo. T. Shuck*

Inventor

*George Vincent*

# UNITED STATES PATENT OFFICE.

GEORGE VINCENT, OF STOCKTON, CALIFORNIA.

## IMPROVEMENT IN LOCOMOTIVES.

Specification forming part of Letters Patent No. **201,308**, dated March 12, 1878; application filed November 12, 1877.

*To all whom it may concern:*

Be it known that I, GEORGE VINCENT, of Stockton, San Joaquin county, and in the State of California, have invented certain new and useful Improvements in Locomotives; and do hereby declare that the following is a full, clear, and exact description thereof, reference being had to the accompanying drawings, and to the letters of reference marked thereon, making a part of this specification.

My invention relates to improvements in locomotives and other railroad-trucks, by means of which they more easily pass around the curves in railroad-tracks. This I accomplish by such construction and arrangement of the parts that the wheels upon each side of the locomotive will follow each other in the line of the track on which they are running, whether such line of track is straight or curved.

In the drawings, Figure 1 is a side view of the running part of a locomotive, showing my invention. Fig. 2 is a longitudinal section of the same. Fig. 3 is a bottom view. Fig. 4 is an end view of one of the boxes in which the end axles turn, with the link or stirrup connected with them, in which is carried one end of the equalizing-bars; and Fig. 5 is a side view of the same. Fig. 6 is a horizontal sectional view of the wrist-pin of the driving-wheels and the box at the end of the connecting-rod, in which the wrist-pin works, with a part of the connecting-rod. Fig. 7 shows the application of my invention with three pairs of driving-wheels.

In the drawings, Fig. 2, C C are horizontal flat thin plates carried upon the end axles, and D is a similar plate carried upon the middle axle. All of these plates are carried underneath another main plate or frame, J, the edge of which is shown in Fig. 1. H are equalizing-bars, Figs. 1, 2, 4, and 5, upon which rest carrying-springs G. The main plate or frame J is carried upon the springs G, and the boiler and its appurtenances are carried upon the main plate or frame J. Short arms extend from the independent end plates C, so as to overlap at the points E similar arms extending from the independent middle plate D. At the points E vertical pivot bolts or pins extend from the short arms of D upward through slots in the short arms of C C. By these con-

nections, as the middle axle is shoved endwise, by impinging against the curved railroad-track which is being passed, it carries with it the middle independent frame or plate D, and thereby the plates C C and the end axles to which they are attached are revolved horizontally around the pivot-bolts at K K, Fig. 2, far enough to throw all the axles in line with the radii of a circle, a part of whose circumference is represented by the curve being passed. At the points K K, immediately over the middle of the end axles, pivot-bolts connect the independent plates C C with the main plate or frame J.

These movements cause the wheels upon each side of the locomotive to follow each other in the line of the track over which they are running.

Proper guards or guides are attached to the main plate or frame J, in which the middle independent plate D may slide.

The boxes in which the middle axle turns have extensions forward and back, and one end of each of the equalizing-bars rests upon one of these extensions, and is fastened to it by a vertical pivot bolt or pin.

As the locomotive changes from a straight track to a curved one, and vice versa, the sliding motion of the center axle and plate D is always directly across the locomotive, and the relative position of the center axle is always at right angles with the length of the locomotive. The end axles, on the contrary, do not move endwise across the locomotive, but partially revolve or swivel in a horizontal direction.

In order to allow the end axles to make this partial swiveling or revolving motion in a horizontal direction freely, and avoid friction which would be caused by allowing the outer ends of the equalizing-bars to rest and slide upon bearings carried by the end axles, I construct links or stirrups to connect with said boxes by a joint that allows the stirrups to swing backward and forward freely. The outer end of each one of the equalizing-bars is placed or swung in the bottom of one of the stirrups, and fastened to it by a vertical pivot bolt or pin.

By these means each end of the end axles may move freely backward and forward over

the outer ends of the equalizing-bars, and the ends of the equalizing-bars may turn horizontally a short but sufficient distance around the pivot bolts or pins that fasten or pivot their outer ends to the bottoms of the stirrups, to allow freedom of motion in the operation of my improvements herein described.

Figs. 4 and 5 show one form of constructing the said boxes and stirrups. Any skilled workman will, however, at once know how to construct them in other forms. In these figures 1 1 are bolts that fasten the boxes to the independent plates C C, and 2 is the hole through the box in which the axle turns. Each end of the box is made round, and extends a short distance along and around the axle, so that a stirrup may be hung to the round extensions of the boxes and swing backward and forward. 3 is the stirrup, and H a portion of an equalizing-bar.

In order to allow the driving-wheels B to move the necessary distance laterally in the locomotive, I construct a wrist-pin of considerable length, and largest for a short distance next to the driving-wheel. This enlarged part may, however, be dispensed with.

In Fig. 6, B is a driving-wheel, and 6 a wrist-pin. 8 is a portion of the connecting-rod that is driven by the engine, and turns the driving-wheel, and 7 is a sleeve or box at the end of the connecting-rod. The wrist 6 works in said sleeve or box. The wrist-pin 6 is made long enough to move endwise in box 7 as the drive-wheels move laterally in the locomotive without imparting any part of the lateral motion to the box 7 or the connecting-rod 8. The outer end of the box 7 is covered and made tight, so that no dust or oil can go through it. The inner end of the box 7 is enlarged to form a sleeve around the large part of the wrist-pin 6, next to the driving-wheel. This sleeve assists largely in keeping dust out of the box 7, and, as the oil with which the wrist-pin is lubricated cannot escape at the outer end of the box, it forms a slow current toward the other end of the box, and prevents dust from entering there.

L, Fig. 1, is a stationary guide, through which the connecting-rod 8 works. This guide L

prevents the connecting-rod 8 from partaking of any of the lateral motion of the wheel B and wrist-pin 6.

Any person skilled in the manufacture of locomotives will understand the proper sizes, proportions, and materials to be used in adopting my invention.

Instead of one pair of driving-wheels being used, two or more pairs may be attached to the middle independent frame, as shown in Fig. 7. In such case the relative positions of all the driving-wheels toward each other remain always the same, and the additional driving-wheels can be connected with the first pair in the ordinary manner. When more than one pair of driving-wheels are used, a part of them can be made without flanges, and thus avoid a large part of the impinging side friction which would be, to some extent, produced by using more than one pair.

My invention applies as well to street-railroads as any other.

The stirrups may be used with equalizing-bars on railroad-trucks that carry the cars.

Having thus described my invention, what I claim, and desire to secure by Letters Patent, is—

1. The wrist-pin 6, with the box or sleeve in which it turns, constructed to operate in combination with the laterally-moving driving-wheels, substantially as and for the purpose herein specified.

2. The guard L, in combination with connecting-rod 8, wrist-pin 6, and the laterally-moving driving-wheels, substantially as and for the purposes herein set forth.

3. The swinging stirrup 3, jointed to the axle-box, in combination with the equalizing-bars H, both in locomotives and other railroad-trucks, substantially as and for the purpose herein set forth.

In testimony that I claim the foregoing I have hereunto set my hand this 20th day of October, 1877.

GEORGE VINCENT.

Witnesses:

ED. J. SMITH,  
M. A. WHEATON.