

W. H. WARD.  
Car-Coupling.

No. 201,312.

Patented March 12, 1878.

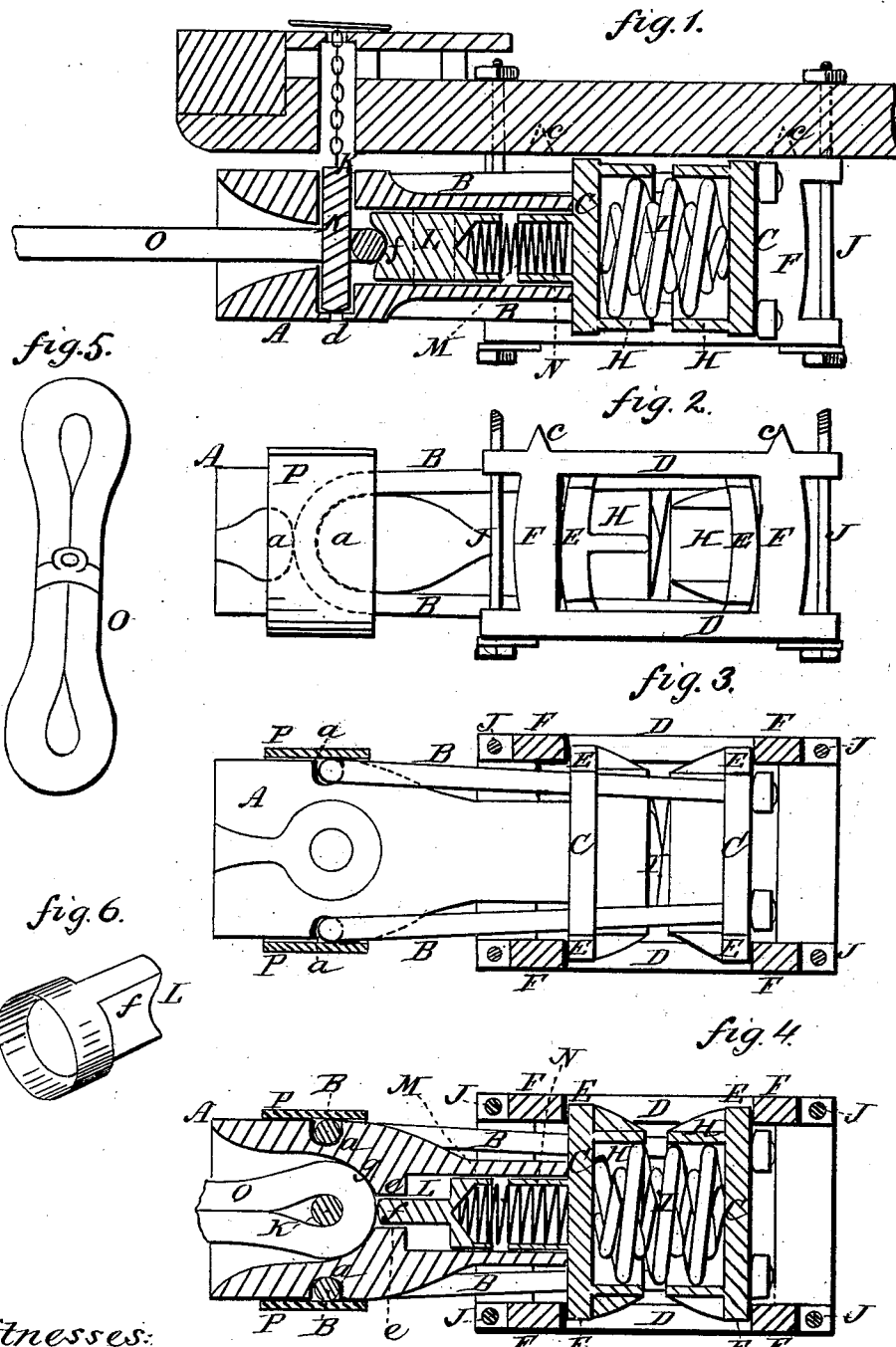

Witnesses:  
Floyd Norris  
A. P. Cowell

fig. 7.

William H. Ward  
by his Attys  
Johnson & Johnson

# UNITED STATES PATENT OFFICE.

WILLIAM H. WARD, OF AUBURN, NEW YORK.

## IMPROVEMENT IN CAR-COUPINGS.

Specification forming part of Letters Patent No. **201,312**, dated March 12, 1878; application filed August 30, 1877.

*To all whom it may concern:*

Be it known that I, WILLIAM H. WARD, of Auburn, in the county of Cayuga and State of New York, have invented certain new and useful Improvements in Railway-Car Self-Couplers, of which the following is a specification:

My improved coupler is designed for use on passenger and freight railway-trains, and is of the class known as "self-couplers." It is also adapted for use with cars of different height. It involves in its construction and combinations important advantages in the particulars of making the draft-connections of the draw-head near or in front of the coupling-pin, and, by means of draft-yokes adapted to each side of said draw-head by interlocking groove or shoulder connections, for operation with followers at the inner end of said draw-head, and connected to the inner ends of the side interlocking yokes in such a manner as to make a strong and simple construction.

The advantages derived from a front draft-connection of the draw-head or coupler are that it prevents all danger of a separation of the parts, and renders the pulling and pushing parts as of a solid piece with great strength.

The bearings of the followers upon their frame or housing are such as to give a center draft at all times, in connection with a draw-head adapted for vertical freedom, in a manner to relieve the yoke groove or shoulder connections with the draw-head from friction and wear, so that, whether the draft upon the draw-heads be upward or downward either in pulling or pushing, the line will be central, thus preventing the followers from unequal draft upon their corners. This is accomplished by making the bearings of said followers upon their housings convex or the segments of circles.

The frame or housing for the followers is provided with dogs or projections, which interlock with the housing-timbers or draft-head plank beneath the platform; and these, in connection with bolts and suitable straps, make a firm fastening for said housing, in a manner to relieve the screw-bolts from the great strain to which they would otherwise be constantly subjected.

The socket for the coupling-link is adapted for close connection for what is known as

"stiff trains," and is formed with a suitable concave seat for the end of the link, so that the latter can only have a working-joint action to conform to the requirements of the cars.

The draw-head is cast with a through-opening to receive a shouldered plug or detent, the front portion of which is of a thickness adapted to move in a slot and top and bottom grooves in the socket of the draw-head, to prevent the detent from turning therein.

A coiled spring bears against the shouldered end of said plug and a socket-neck from the front follower, fitted into the through-opening of the draw-head, to project the detent or plug forward in position beneath the coupling-pin, to maintain the latter in position for coupling, and, when the coupling-connection is effected, to press against the inner end of the coupling-link.

The followers are permanently secured to the side yokes, and the neck of the inner follower forms a brace and support for the inner end of the draw-head, so that all the parts are made separate, to be easily fitted and secured together; and the draw-head, the yokes, and the followers form a single structure of fixed parts, in which the pulling or pushing is borne by springs or cushions arranged between said followers.

In the drawings, Figure 1 represents a vertical longitudinal section of a draw-head embracing my invention, the parts being shown in positions when the cars are coupled; Fig. 2, a side view of the same; Fig. 3, a top view of the same, the housing being in section; Fig. 4, a horizontal section of the parts shown in Fig. 3; Fig. 5, the strapped coupling-link; Fig. 6, the detent or plug for the coupling-pin; and Fig. 7, a coupling-link for high and low cars.

The draw-head A is cast with grooves or double shoulders *a a*, one on each side, adapted to receive yoke draft-rods B, which are long enough to extend back of the draw-head a sufficient distance to connect with and carry followers C C, the rear one of which is secured thereto by screw-nuts.

The open ends of the yoke-rods pass through openings in the corners of said followers, while their front ends are rounded to fit over the

corresponding shoulders *a* of the draw-head at a point near or in advance of the coupling-pin, so that the draft is directly from the solid front end of the draw-head, and not from piece connections at the rear end, as heretofore.

It is by this construction that I am enabled to use two side-draft yokes having a fixed connection with the followers, and making a very strong coupling attachment, adapted for freight or passenger trains.

The yoke draft-rods B, while drawing from the front end of the draw-head, serve also as supports and braces for the draw-head at the points where the yokes pass over its shoulders.

The followers C are adapted to work within a housing or metal frame, D, secured to the draft-head plank, their opposite sides being extended to form bearings E E, fitted to bear upon the standards F F of said housing, and held in place by the horizontal top and bottom bars D D, which connect said standards.

The followers are provided with cup-sockets H, to receive a strong coil spring or springs, I, which I prefer to have a double spring, one within the other, with reversed coils, and upon which the draw-heads pull or push the cars. There is a peculiarity in the bearings E of these followers C upon the housing, in being made convex or segments of a circle, Fig. 2, so that the draw-head, which is adapted to have a certain amount of vertical freedom, will always pull in a direct line, and thereby relieve the corners of the followers from all strain, and make the draft upon them uniform at all points.

The housing is secured to the draft-head plank by vertical bolts J J; and to relieve these of undue strain, the side plates of the housings are provided with projections or dogs *c* at their upper edges, which fit into corresponding notches in the under side of the draft-head plank, giving a very firm connection.

The coupling-pin K works through a vertical opening in the draw-head, and, when in place, is supported upon a shouldered seat, *d*, in the lower side of said draw-head.

The coupler is adapted for automatic coupling; and for this purpose the coupling-pin is supported, when uncoupled, by a plug or detent, L, arranged within the draw-head in position to be forced out beneath the coupling-pin when it is raised to release the coupling-link.

In coupling the cars, the link presses the plug or detent, and, pushing it back, allows the pin to drop and effect the coupling.

The draw-head has a through-opening, the middle portion of which opens into the link-receiving end, forms a slot, *e*, with an upper and a lower groove, within which the narrow straight end *f* of the plug or detent L works, while its rear end is cylindrical with a socket, and works within the through-opening back of the slot, and receives one end of a coiled spring, M, whose opposite end is fitted in a

neck-socket, N, of the pushing-follower, which fits into the rear end of the draw-head. This connection joins said follower to the inner end of the draw-head by a firm bracing union, and gives the advantage of fitting the plug or detent and its operating-spring in place from the rear end of the draw-head, and forming an interior shoulder, against which the shoulder-detent strikes to limit its outward projection.

It is the particular construction of these parts which is new, so far as I know, and it is not intended to claim, broadly, a detent-slide by which to effect the automatic coupling.

The bracing-neck N of the follower co-operates with the bracing action of the draft-yoke shoulders to render the parts rigid, as if of a single piece.

The draw-head has a flaring mouth, the inner end of which forms a close seat or socket, *g*, Fig. 4, for the coupling-link O, so as to form, when coupled, a stiff connection—that is, allowing the link horizontal or side play—the draw-head itself having a suitable vertical freedom, and so constructed as to prevent accidental uncoupling.

The coupling-link may be adapted for cars of different height in connection with the flaring mouth of the draw-head.

There is a great advantage in having all the parts of the coupler adapted for ready attachment, and especially in having the draw-head, its side-draft yokes, and followers united to form a single device or structure, which draws or pushes upon the springs between the followers.

The usual draw-head strap P embraces the forward ends of the yoke-rods and the draw-head, retaining said yoke-rods upon their seats or within the grooves of the draw-head.

To make the connecting-link a rigid pushing-driver, it has its sides closed together and strapped in such manner as to prevent them from separating, as in Fig. 7. A chain-connection with the strap serves to secure the link to the car.

For extreme difference in platform heights, the link is bent, as shown in Fig. 8.

The short coupling-pin, Fig. 1, being headless, or a straight piece of ordinary round metal of suitable size, I form in the bottom of the draw-head a seat, *d*, so that in the event of the breaking of the pin or its uncoupling-chain, the pin or its parts will be retained in working position.

The purpose of the cups H, projecting toward each other from the followers C, is to inclose and form seats for the spring I, and to allow the followers to have a limited movement against the spring, and when brought together, either in pulling or pushing, to serve as abutments in protecting the spring from being crushed, which action would be liable were it not for the protection afforded by said follower-cups.

I claim—

1. The draw-head of a car-coupler having

projecting shoulders *a a* on its opposite sides, as a means for connecting said draw-head with the spring-followers.

2. The draft-yokes *B*, in combination with side projecting shoulders *a a* and the spring-followers *C*, as herein set forth.

3. The followers having segmental end bearings *E E*, for the purpose stated.

4. The combination, with the convex or segmental bearings of the followers and the draft-yokes, of the vertical housing-bearing, substantially as set forth.

5. The combination, with the projecting side shoulders at or near the front end of the draw-head, and the draft-yokes interlocking therewith, of the retaining-strap, as set forth.

6. The draw-head having the projecting side shoulders, the draft-yokes interlocking therewith and connected with the followers, in combination with the fixed housing, as set forth.

7. The draw-head having the concave socket-bearing *g*, and the coupling-link *O*, having a corresponding bearing fitting end, in combination with the plug or detent *f L*, whereby lost motion of the coupling is obviated.

8. The followers *C C* having the cups *H*, in combination with the inclosed spring *I* and the coupling draw-head, whereby the spring is prevented from being crushed by the followers, as set forth.

9. The draw-head having a through-opening, shouldered to form the plug-seat, in combination with the follower-neck, fitting in said opening, whereby the draw-head is braced and supported, and the plug and its spring inserted at the rear end thereof.

10. The housings provided with dogs, in combination with the fastening-bolts, as set forth.

11. The coupling-link having its sides closed together and strapped, for the purpose set forth.

12. The headless coupling-pin *K*, in combination with the seat *d*, as and for the purpose described.

In testimony whereof I have hereunto set my hand.

W. H. WARD.

Witnesses:

A. E. H. JOHNSON,

J. W. HAMILTON JOHNSON.