

A. F. FOSTER.
 Device for Finishing the Sockets of Sewer-Pipes.
 No. 201,342. Patented March 19, 1878.

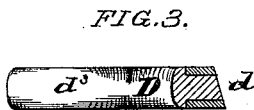
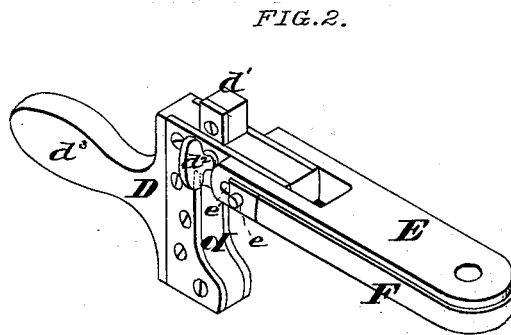
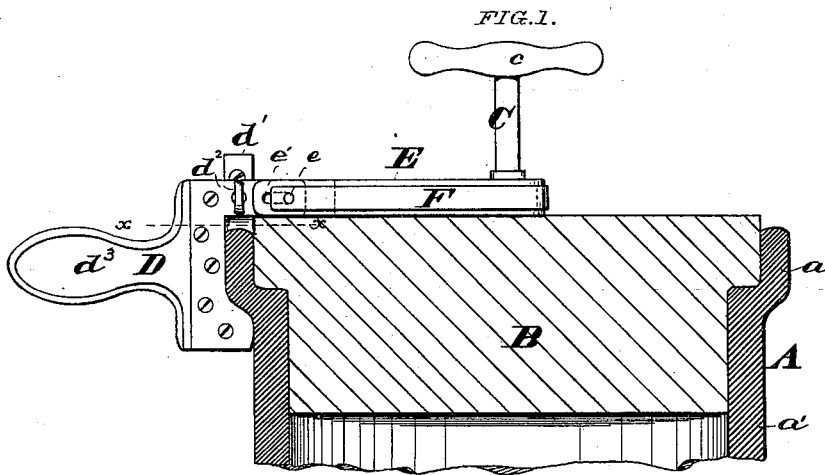

ATTEST:
Samuel Marsden
Saml. S. Boyd

INVENTOR:
Alfred F. Foster,
 by *Chas. S. Moody,*
att'y

UNITED STATES PATENT OFFICE.

ALFRED F. FOSTER, OF ALTON JUNCTION, ILLINOIS, ASSIGNOR OF ONE-THIRD HIS RIGHT TO MARIANNE LEVIN, OF ST. LOUIS, MO.

IMPROVEMENT IN DEVICES FOR FINISHING THE SOCKETS OF SEWER-PIPES.

Specification forming part of Letters Patent No. 201,342, dated March 19, 1878; application filed October 22, 1877.

To all whom it may concern:

Be it known that I, ALFRED F. FOSTER, of Alton Junction, Madison county, Illinois, have invented a new and useful Device for Finishing the Sockets of Sewer-Pipes, of which the following is a full, clear, and exact description, reference being had to the annexed drawing, making part of this specification, in which—

Figure 1 is a longitudinal section of the socket end of a sewer-pipe, showing the invention in position; Fig. 2, a view, in perspective, of the device; and Fig. 3, a detail, being a cross-section of the finisher proper, taken on the line *x x*, Fig. 1.

Similar letters refer to similar parts.

Heretofore it has been customary to finish the sockets of sewer-pipes by hand. Thus finished, the operation is expensive, necessitating skilled labor. The sockets are not always accurately formed, and the clay used in their formation is not compressed as thoroughly as that in the body of the pipe.

By means of the present improvement the difficulties referred to are overcome. The sockets are readily, neatly, and uniformly finished, even by unskilled persons, and the clay in them is subjected to considerable pressure, sufficient to express the air.

Referring to the annexed drawing, A represents the socket end of an ordinary sewer-pipe. B represents a plug, in shape and size corresponding to the interior of the pipe, and extending from the outer end, or thereabout, of the socket *a* inwardly into the body *a'* of the pipe. C represents a bearing arranged longitudinally and centrally in the plug, and projecting from it, as shown. D represents what I term the "finisher proper." It is pivoted at *e* to an arm, E, that, in turn, is arranged to rotate upon the bearing C. The distance from the center of the bearing C to the inner corner of the face *d* of the finisher (when the latter is in position) is one-half of the exterior diameter of the socket *a*. The inner face *d* of the finisher is shaped to conform to that of the intended socket.

In operation, the various parts are arranged

as in Fig. 1—that is, the plug, having the arm and finisher attached, is placed centrally within the pipe, and far enough into the body of the pipe to insure its being steadily held. The arm and finisher are then swept around upon the bearing C, bringing the inner face of the finisher repeatedly against the outside of the socket, and compressing the clay against the plug within. The face *d* of the finisher is beveled, as shown more distinctly in Fig. 3, to enable the finisher, as it moves around, to ride upon the clay and gather it between the finisher and the plug. That portion, *d*, of the finisher that is used in forming the end of the socket-flange *a'* is preferably made adjustable to suit flanges of different depths, and also to provide for wear. It can be set up or down to any desired height, and is then fastened by the set-screw *d*². Its face—or that surface that comes against the clay—is also beveled, to serve the same purpose as the bevel of the face *d*. The pin *e*, that forms the connection between the finisher and arm, is preferably arranged in an elongated bearing, *e'*, in the arm E, and made to project therefrom. To these projecting ends an elastic band, F, is attached, passing thence around the inner end of the arm, and adjusted so as to cause a tension upon the pin *e*, and operating to hold the finisher up against the pipe. It not only aids in sustaining the finisher, but enables the latter to accommodate itself to any unyielding part of the clay.

When the socket is finished, the finisher is, by means of the handle *d*³, upturned on the bearing *e'*, so as to clear the socket, and then the entire device, by means of the handle *c*, is withdrawn from the pipe.

I claim—

1. The combination of the plug B, bearing C, finisher D, and arm E, substantially as described.
2. The finisher D, having the adjustable part *d*¹, as and for the purpose described.
3. The finisher D, having the beveled face *d*, substantially as and for the purpose described.
4. The combination of the arm E, having

the elongated bearing *e'*, the pin, the finisher D, and the elastic band F, substantially as described.

5. The combination of the finisher D and the arm E, substantially as described.

6. The combination of the bearing C, arm E, and finisher D, substantially as described.

7. In making sewer-pipes, a finisher, D, ar-

ranged to swing around the center of the pipe, and to compress and finish the socket, substantially as described.

ALFRED F. FOSTER.

Witnesses:

CHAS. D. MOODY,

HEYMAN LEVIN.