

G. H. LITTLE & J. S. SMART.

Valve.

No. 201,352.

Patented March 19, 1878.

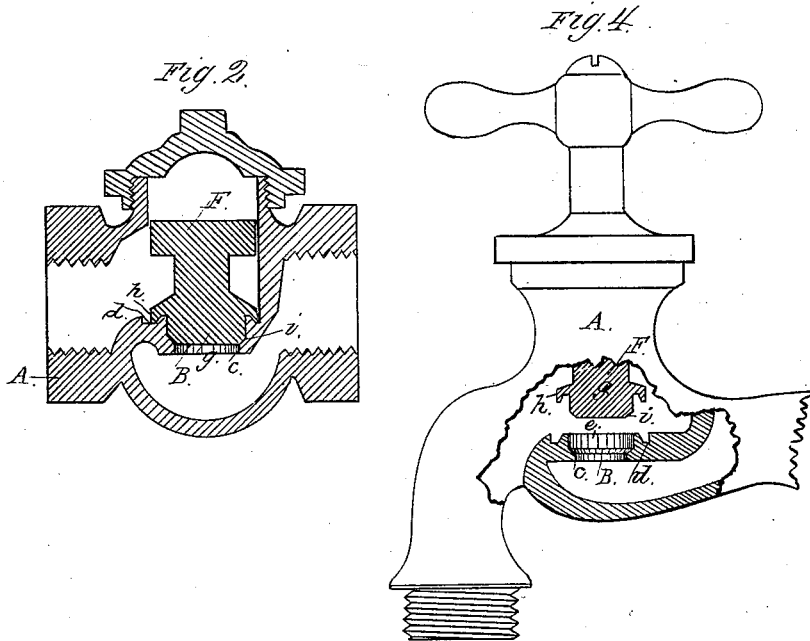
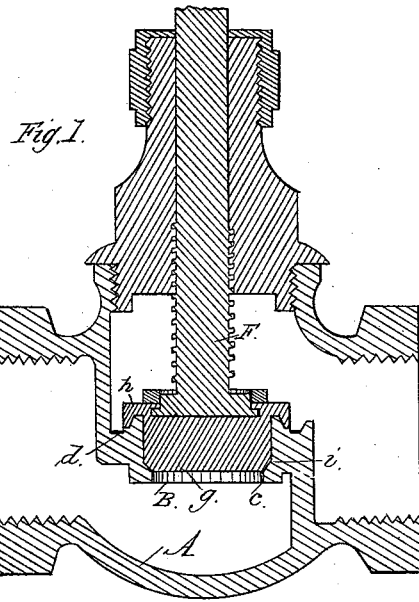

Attest
Geo. T. Smallwood Jr.
Permy & Co.

Inventors
George H. Little &
James S. Smart
By John J. Halsted
Atty

G. H. LITTLE & J. S. SMART.
Valve.

No. 201,352.

Patented March 19, 1878.

Fig. 3.

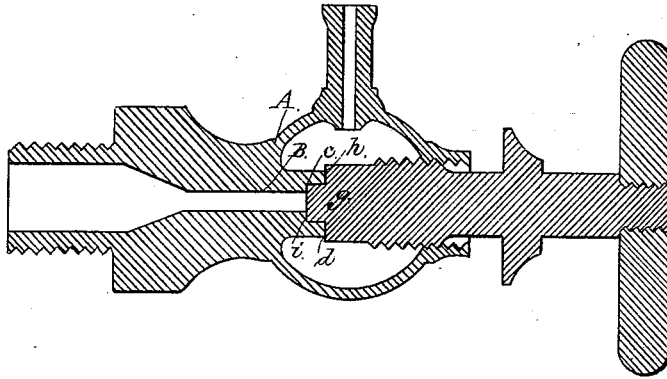
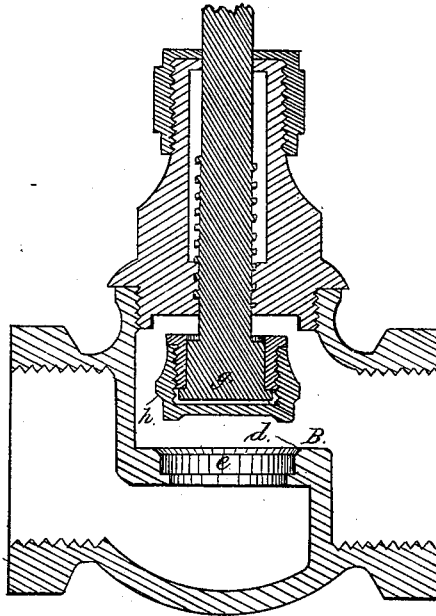

Fig. 5.



Attest:
Geo. T. Smallwood Jr.
Per Halsted

Inventors:
George H. Little &
James S. Smart.
By John J. Halsted
Atty.

UNITED STATES PATENT OFFICE.

GEORGE H. LITTLE, OF PEABODY, AND JAMES S. SMART, OF SALEM,
MASSACHUSETTS.

IMPROVEMENT IN VALVES.

Specification forming part of Letters Patent No. **201,352**, dated March 19, 1878; application filed
December 27, 1877.

To all whom it may concern:

Be it known that we, GEORGE H. LITTLE, of Peabody, and JAMES S. SMART, of Salem, both in the county of Essex and State of Massachusetts, have invented certain new and useful Improvements in Valves, which improvements are fully set forth in the following specification.

Our invention has for its object the making of a tight valve which steam or liquids will not cut, and it is applicable to valves generally, including check-valves, gage-cocks, and faucets; and to this end it consists in a double-seated valve, both of the seats seating at the same time, one being of larger diameter than the other, and with an expanding chamber located between them, and a plug, which, while adapted to seat upon both said seats, also fills, or nearly fills, the expanding chamber.

It has long been a desideratum to produce devices which would make a satisfactory tight valve for steam and liquids; but, so far as we are aware, it has not hitherto been done. But our present invention accomplishes this end or purpose, and overcomes the difficulties heretofore experienced. Among these difficulties may be named the cutting of the valve, and also the cutting of the valve-seat.

In some cases means have been devised seeking to remedy the cutting of the valve, and in other cases means for avoiding the cutting of the seat; but in our invention we provide for both, and construct and arrange both the valve and its seat, as hereinafter described, so that the steam or liquid will not cut either of them.

In the drawings we have shown valves adapted for different uses, but to each and all of which our improvement is applicable.

The same letters refer to similar parts in all the figures.

Figure 1 represents a valve embodying our invention, A being the body of the valve; B, the passage or opening through the same connecting the inlet with the outlet; *c*, the lower seat, which is also the smaller and inner one; *d*, the upper seat, and which is also the outer one, and of the larger diameter; *e*, the expanding chamber located between these two seats, it being, of course, understood that this cham-

ber may be of any desired dimensions and the distance or height between these two seats varied, as circumstances or the character of the valve may demand, but always provided that the passage B be of lesser diameter than the chamber *e*.

F represents the double valve stem or plug, of which *g* represents the tight or nearly tight fitting plug portion of the valve, and which fills, or nearly fills, the expanding chamber *e*; and *h* and *i* represent, respectively, the two valve-seats of this plug, of which *h* (the upper and larger one) is adapted to seat upon the seat *d*, above described, and *i* (the lower and smaller one) is adapted to seat upon the seat *c*, above described.

As shown in Fig. 1, the seats are beveled in form, *c* beveling inward and *d* beveling outward, and the plug F has its seats also beveled correspondingly; but these seats may be flat, instead of beveled, both in the body of the valve and in the plug, provided there be two seats, and that the seating be simultaneously made by both seats. The beveled form, however, I prefer, because it affords a tapering contact of the surfaces, acting in the nature of a wedging action when tightening or closing the valve.

From this construction the following advantageous results follow, as will be readily seen, namely: First, the valve has not only a double-seating but also a tight-fitting plug, and this plug located between the two seats; second, the upper seat *d* is made in such manner that the steam will not come in contact with it; third, the plug *g*, being tight fitting in the expanding chamber *e*, allows but a very small amount (if any) of steam to escape until the valve is wholly removed from said chamber, and is away from the opening B of the valve-seat. Therefore it allows the steam to pass up and out of the valve without cutting either of the two seats.

The seats may be made of any metal or composition adapted or suitable for making a tight joint.

In Fig. 1 is shown a valve. In Fig. 2 is shown a check-valve; in Fig. 3, a gage-cock; in Fig. 4, a faucet, all having our invention applied therein, the double seat and the inter-

vening chamber being shown in all. In Fig. 5 the valve shows our expanding chamber having one seat instead of two, but with the tight-fitting plug adapted to fill said expanding chamber below the seat.

In all the figures it will be observed that the expanding chamber *e* is of greater diameter than the opening B, which latter determines the size of the valve.

In a one-inch valve—that is, one in which the opening B has a diameter of one inch—the diameter of the expanding chamber *e* and of the plug which fills it will be greater. Upon moving or raising the plug away from the opening B it does not permit the steam or liquid to cut or rake the valve as the plug is being raised out of the expansion-chamber; but it checks it in part before it leaves the chamber, and reduces the harshness of the steam, and it is not so liable to cut.

It will be seen that if the opening B were of the same diameter as the part *e*, the latter would cease to be a chamber, and the advantages incident to such a chamber could not attach to a valve of such construction.

It will also be seen that in no instance, in our mode of construction, need the plug project through and beyond the opening.

We are aware that valves have been made in which the steam will not pass the valve at the instant the latter commences to lift or to be lifted; but this does not constitute an expansion-chamber in the sense in which we employ that term.

To form our expansion-chamber, it is necessary that the inlet to the space in which the valve-body moves shall be of smaller diameter than the main part of the space, so that the steam expands substantially at right angles to the direction in which the valve moves.

We claim—

1. A valve provided with an expansion-chamber of diameter greater than the valve-opening, and with a plug or stem adapted to fit tightly in such chamber, substantially as and for the purpose described.

2. A double-seated valve having one opening for both seats, and both seating-surfaces adapted to seat simultaneously, in combination with a tight or nearly tight fitting plug for the chamber between such seats, substantially as and for the purpose set forth.

3. The two valve-seats *c* and *d*, and the expanding chamber provided with the opening B therein, substantially as shown and described.

4. The plug-valve *g*, constructed with its two seating-surfaces *h* and *i*, and the tight-fitting plug portion *g*, in combination with the spindle for operating the valve, substantially as shown and described.

5. A valve having a tight-fitting plug in an expanding chamber located above the valve-opening.

6. A valve provided with an opening or chamber, *e*, of larger diameter than that of the hole through the valve, and provided with a tight or nearly tight fitting plug, operating to prevent the steam from passing beyond it until it is removed from such expanding chamber, for the purpose described.

7. A double-seated valve and plug, either with a bevel or a flat seat, and provided with an expansion-chamber between the seats, substantially as shown and described.

GEORGE H. LITTLE.
JAMES S. SMART.

Witnesses:

L. W. KELLEY,
WILLIAM A. PITTS.