

A. H. UFFORD.
Land-Roller.

No. 201,368.

Patented March 19, 1878.

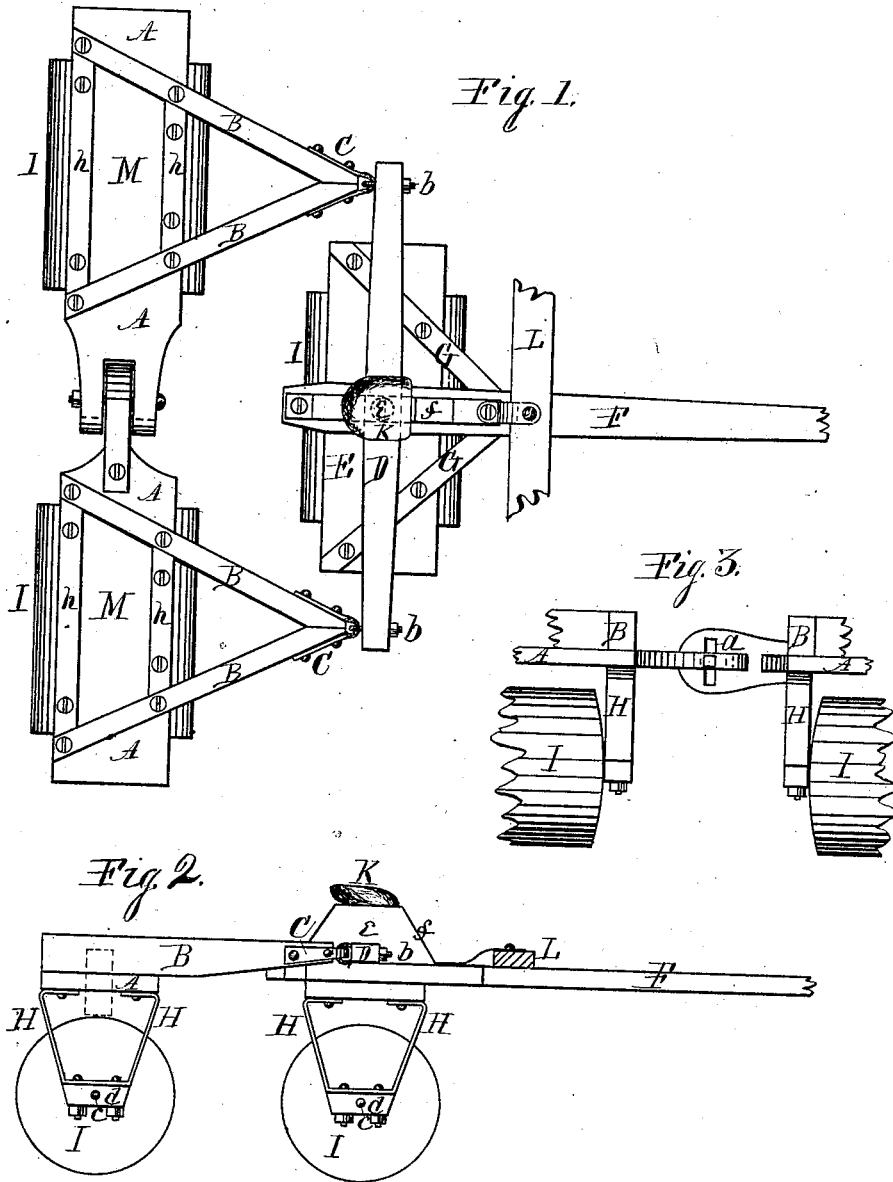

Witnesses:
A. O. Behel
C. C. Hill.

Inventor:
Alfred H. Ufford.
Per Jacob Behel.
Atty

UNITED STATES PATENT OFFICE.

ALFRED H. UFFORD, OF ROCKFORD, ILLINOIS.

IMPROVEMENT IN LAND-ROLLERS.

Specification forming part of Letters Patent No. **201,368**, dated March 19, 1878; application filed February 5, 1878.

To all whom it may concern:

Be it known that I, ALFRED H. UFFORD, of the city of Rockford, in the county of Winnebago and State of Illinois, have invented a new and useful Improvement in Land-Rollers, of which the following is a specification:

This invention relates to that class known as "three-section rollers."

The object of my invention is to produce a cheap and efficient three-section roller, in which each roll is fitted to revolve on central end journals in bearings on separate supporting-frames, which are connected to each other by hinge-joints to form a flexible frame, in such a manner as to permit the several rolls, respectively, to operate on the same or different horizontal or inclined planes, to more perfectly adapt themselves to the irregular surface of the ground. These and other improvements, which will be hereinafter described, constitute the subject-matter of this patent.

In the drawings, Figure 1 is a plan view of a three-section land-roller embodying my invention, of which Fig. 2 is a side elevation, and Fig. 3 is a rear elevation, of the central portion of the rear rollers.

In the figures, A are bed-pieces, of suitable material and of proper size, which form the base of the rear-roll frames. B are bracing-beams, secured crosswise to the upper side of the base-pieces, in such oblique position that their forward ends meet at a proper distance in front of the forward edge of the base-pieces, where they are fitted and connected by a clasp, C, of V form, embracing their outer sides and secured firmly thereto. These frames are placed end to end, in such a manner as to bring the base-pieces in line, which are connected at their contiguous ends by a loose hinge-joint, constructed with a vertical slot, *a*, to permit of an independent and joint vertical movement of the ends of the frames.

The V-formed clasps C, at their forward ends, are of ring-loop form, to receive a hook-eye, *b*, forming hook-and-eye joints, by which they are connected to the outer ends of an equalizing-bar, D. These parts constitute the frame of the rear rolls.

E is the bed-piece of the frame of the forward roll, and is of proper material and size. F is the tongue, the rear end of which is se-

cured to the upper surface of the bed-piece E crosswise, in the center of its length, and is supported by braces G, which meet the tongue in advance of the forward edge of the bed-piece, and extend rearward and outward obliquely across the upper face of the bed-piece, to which they are firmly secured. These parts constitute the frame of the forward roll. These frames are fitted at each end with down-hangers H, which, in this instance, are made from suitable bar material, bent into proper form, and depend from the under side of the ends of the bed-pieces, to which they are firmly secured.

I are rolls of proper size, and, in this instance, are of wood, with parallel sides, and of cylindrical form, solid, provided centrally with end journals *c*, fitted to revolve in bearings *d*, secured to the lower ends of the down-hangers, in such a manner as to be readily removed when worn, and new ones substituted. These frames, with the rolls in place, are connected in a flexible manner by means of a king-bolt, *e*, which is passed through the center of the equalizing-bar D into the tongue and the frame of the forward roll.

K is a driver's seat, mounted on the forward-roll frame, on a bracket secured to the tongue, spanning the equalizing-bar D. The evener L, to which the team is to be attached, is pivoted to the tongue in the usual manner. Weight-boxes M are formed on the frames of the rear rolls by bars *h*, fitted between the angling braces B at the front and rear edges of the bed-pieces A.

In the use of my improved land-roller the beam is attached in the usual manner, and the driver is carried mounted on the machine in the seat; and, if required, the rear rolls may be loaded by placing weights in the boxes M to increase their crushing force.

By means of the above-described devices, their construction, arrangements, and several combinations, I am enabled to produce a flexible land-rolling machine in which each of the several rolls employed will be free to adapt itself to operate on the same or different horizontal or inclined planes, to adapt itself more perfectly to the inequalities of the surface; a roller that is easy to operate, and that can be readily turned in any direction, and

also produce a strong and reliable machine of cheap construction, and easily repaired when worn or broken.

I claim as my invention—

1. In a land-roller frame, the combination, with the converging braces, having their forward ends attached to the equalizing-bar, of the bed-pieces of each rear-roller frame and braces *h*, located on the front and rear edges of said bed-plates, whereby said braces *h* serve to strengthen the converging braces, and also constitute the sides of the weight-boxes, substantially as set forth.

2. A land-roller composed of three independently-adjustable rollers, the rear and front roller-frames having no connection with each other, the rear rollers being adjustably secured to the end of the equalizing-bar, and adjustably secured to each other by means of a single joint, located in line with the tongues of the roller, substantially as set forth.

ALFRED H. UFFORD.

Witnesses:

A. O. BEHEL,
C. C. HILL.