

C. EWING. Numbering Machine.

No. 201,401.

Patented March 19, 1878.

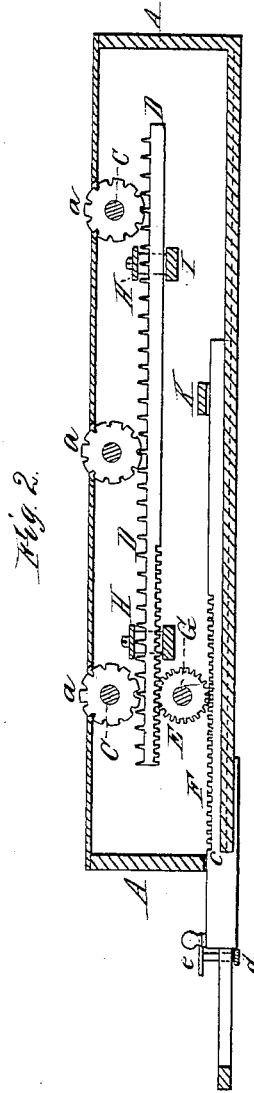
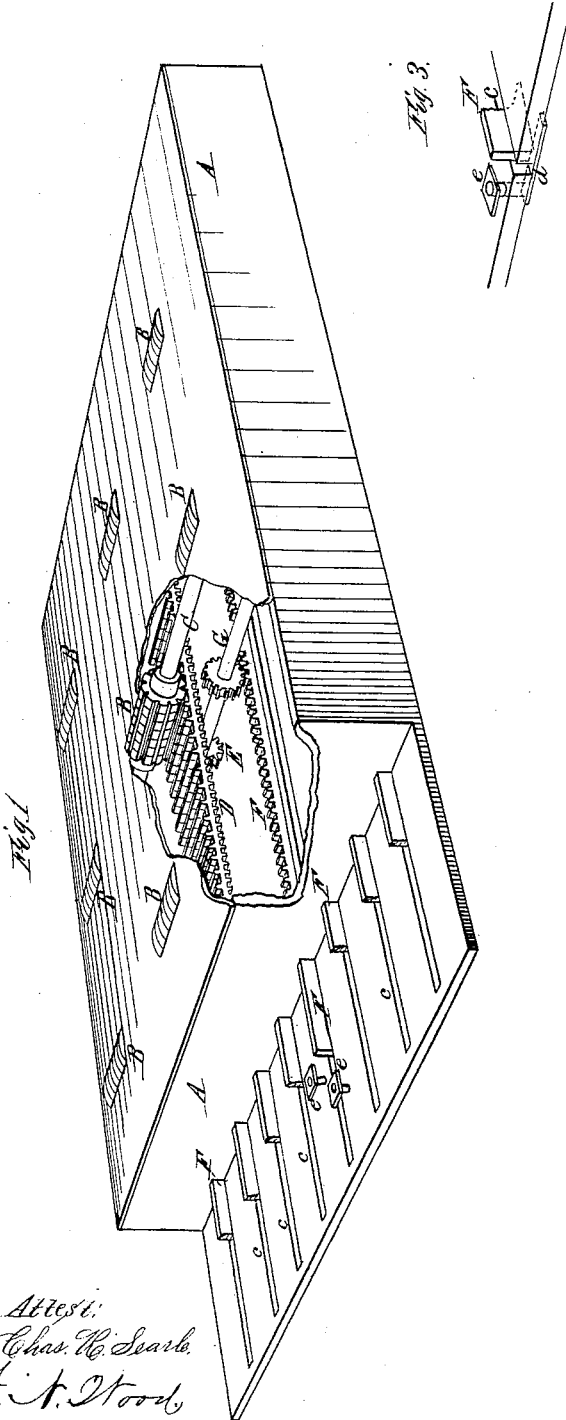

Attest:
 Chas. H. Seab.
 H. J. Wood

Charles Ewing,
 Inventor,
 By North Clifford,
 Attorney.

C. EWING.
Numbering Machine.

No. 201,401.

Patented March 19, 1878.

Fig. 6

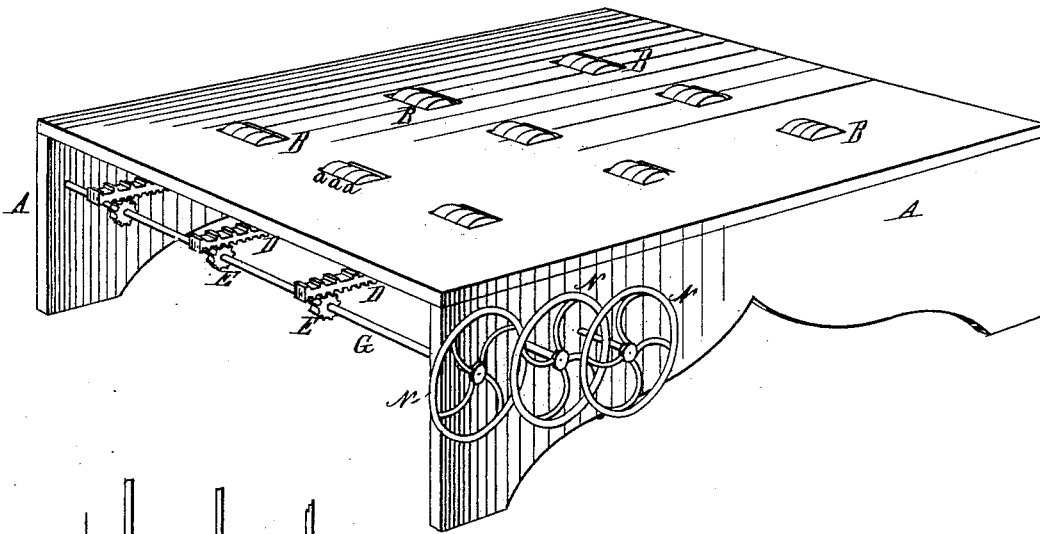
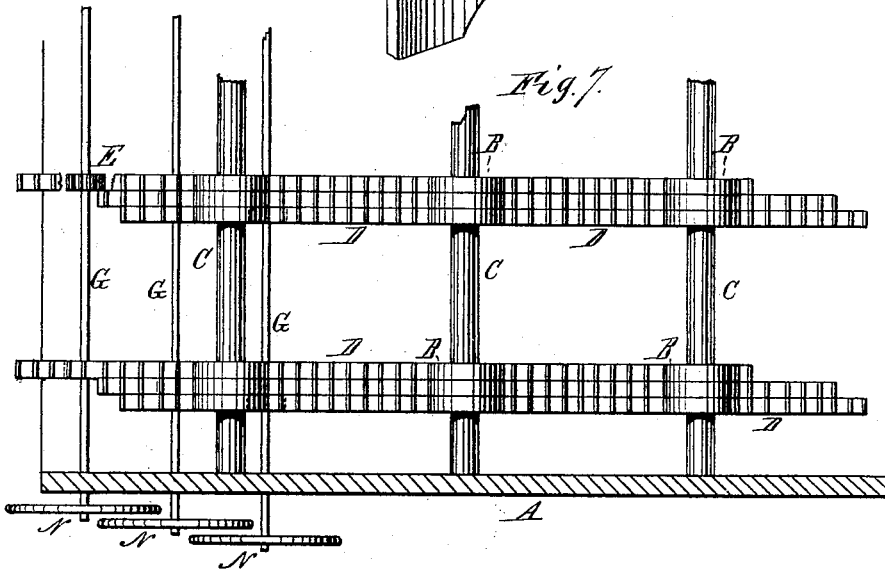

Fig. 7



Attest:
Chas. H. Searle,
W. A. Ford

Charles Ewing,
Inventor:
By North & Board,
Attorney.

UNITED STATES PATENT OFFICE.

CHARLES EWING, OF WASHINGTON, DISTRICT OF COLUMBIA.

IMPROVEMENT IN NUMBERING-MACHINES.

Specification forming part of Letters Patent No. 201,401, dated March 19, 1878; application filed December 3, 1877.

To all whom it may concern:

Be it known that I, CHARLES EWING, of Washington, county of Washington, and District of Columbia, have invented certain new and useful Improvements in Numbering and Printing Machines, of which the following is a full, clear, and exact description, reference being had to the accompanying drawings, and to the letters of reference marked thereon.

Figure 1 is a perspective view of the improved machine, a portion being broken out to show the relative arrangement of the several operating parts which are connected with one of the numbering-heads, and only two of the operating-keys being shown in position. Fig. 2 is a longitudinal section upon a plane passed between any two of the numbering-wheels. Fig. 3 is a detached view, in perspective, illustrating the location and arrangement of one of the springs for arresting the ratchet and its operating-key. Fig. 4 is a plan view of the machine completed, the cover or top plate being removed. Fig. 5 is a section upon line *xx* of Fig. 4. Fig. 6 is a perspective view, illustrating a modified means of moving the ratchets which engage directly with the numbering-wheels; and Fig. 7 is a plan view of a fragment of such modified machine.

Like letters in all the figures indicate corresponding parts.

The object of my invention is to produce a machine capable of printing a series of numbers or figures at one impression upon any desired number of stamps, coupons, tickets, &c., in order to reduce the cost of such numbering below that resulting from the employment of the common numbering-machines, and to render the improved device simple in construction, easy to be operated, not liable to get out of order, or to print an erroneous figure, and otherwise desirable and convenient for the purposes intended.

To accomplish this the invention consists, essentially, in arranging any desired number of groups of printing-wheels upon a continuous surface, whereon the paper is to be laid, the wheels in each group being operated by such mechanism as shall render each wheel perfectly independent of all the other wheels in the group, and yet make all the wheels corresponding to each denomination throughout

the system capable of being moved simultaneously; and it further consists in certain novel arrangements or combinations of operating mechanisms, as will be hereinafter fully described, and then pointed out in the claims.

The principal difficulties existing in the present styles of machines of this class which it is desirable to overcome are these:

First, the ordinary numbering-machine has but a single head or group of numbering-wheels, rendering it impossible to print but a single group of figures at one impression, and the use of this implement necessitates a vast amount of labor in numbering such articles as coupons for bonds, which, for instance, may be one hundred in number, and be required to bear the same characteristic figures as the bond itself.

Second, in all machines heretofore constructed which are capable of duplicating the above-named numbering-head, the several wheels in each head have been so connected as that one figure is brought into position by the movement of the one next preceding. This connection frequently causes the wrong figure to be brought uppermost—an error not capable of being corrected without considerable trouble and inconvenience; and, moreover, it practically prevents the omission of certain figures, which, for purposes of detecting fraud or counterfeiting, is frequently desirable in the printing of such matters as revenue-stamps and the like.

To illustrate the principles of my invention, I have chosen the devices shown in the accompanying drawings, wherein—

A is the frame-work of the machine, adapted to contain the several groups of numbering-heads B B, &c. Each of these heads are shown as composed of seven wheels each, so that numbers as high as millions may be printed.

The wheels *a a* are mounted upon the axles C, and are turned by the ratchet-bars D, the teeth of which engage in the spaces between the several numbers. Each of the ratchet-bars D has a ratchet cut in its under face to receive the teeth of the operating-wheels E, which wheels are turned by a second ratchet-bar, F, projecting out through the front of the box.

In order that the several wheels *a*, corresponding to the units-place of figures, may be simultaneously moved, all these operating-wheels *E*, which govern the units-wheels, are mounted upon a single shaft, *G*, and turn therewith.

From this construction and arrangement it is apparent that the several units-wheels are moved at the same time by simply pulling out or pushing in the corresponding ratchet *F*; and also that no movement of the unit-wheels can disturb the tens or any others throughout the system, since they are all held fast by their ratchets. The tens-wheels are similarly connected, as are also the hundreds, thousands, and so on throughout the system.

The operating-wheels are placed in regular procession, as shown in the plan, so as not to interfere with any other parts of the mechanism, and in order to afford a uniformity of space between the operating-ratchets upon the key-board, for convenience in manipulating them.

The shaft *G*, and all the other shafts which carry the manipulating-wheels, are intended to be provided with a coiled spring, *b*, the elasticity of which is increased when the wheels are at their starting-points, and which aids or completely moves said shaft when the under ratchet is released by means hereinafter to be referred to. These springs may be connected in any other desirable manner with the operating parts of the instrument.

The ratchets *D* are prevented from spreading by the bridges *H*, which are secured to the pieces *I*, whereon ratchets *D* find a support near each end; and ratchets *F* are similarly sustained in proper working position by being run in channels *c*, cut in the bed-plate or foundation-bars, in which channels they may be confined by the bridges *K K*.

The axles *C* are made sufficiently strong to withstand the pressure brought to bear upon the several heads; and they may be supported by suitable arms at intervals, if found desirable.

A top plate is intended, of course, to be placed upon the frame-work to complete the bed of the press. The heads project through this bed at the desired points; and the inking apparatus, as well as the means for producing the required impression, may be of any suitable character, it not being deemed necessary to illustrate them herein.

The ratchets *F* are arrested in their outward movement by springs *d*, attached to the under face of the key-board. These springs are pushed downward by the keys *e*, and when any one of them is so depressed it permits the ratchet to be moved onto the next one, either by the force of the coiled spring *b* or by the hand, if desired. For convenience, the several keys are arranged alternately upon the sides of the bar *F*, as shown in the plan, Fig. 4, and this arrangement operates to prevent the movement of the ratchet in case the wrong key be touched or depressed, or in case two

keys upon one side of the ratchet be depressed at the same time. It is not probable that the operator would touch two keys upon opposite sides of the bar without intending so to do; and one having been manipulated, the bar cannot pass beyond the spring upon the opposite side until it has been in like manner disturbed.

When either ratchet has been withdrawn to its fullest extent, it is only necessary to return it to its normal position in order to repeat the figures which it controls.

Instead of controlling the numbering-wheels by means of the second or lower ratchet-bar through the medium of the operating-wheels, as above described, the invention contemplates the employment of hand-wheels *N N N* upon the projecting extremities of shafts *G G*, as in Figs. 6 and 7; and these hand-wheels may be arrested at the desired points by suitably-applied springs or other stops.

In either form of machine it is obvious that, should an error occur in the printing, it is only necessary to properly adjust the ratchet or hand wheel which governs the denomination or place of figures in which the error is discovered, and this may be done without disturbing any of the other wheels.

The mechanism being of the simplest and most positive form, any errors which arise during its use must be the result of carelessness upon the part of the operator, and could scarcely be attributed to any disarrangement or complication in the machine itself.

With this device it is entirely practicable to omit any figure agreed upon for purposes of detecting counterfeiting, &c. For instance, it may be determined to print no figure 9 or 2 in the place of thousands, and no figure 7 or 3 in the place of hundreds. The operator has only to omit these figures, as in the ordinary adjustment of the printing-wheels, and the remaining wheels are not disturbed. With the forms of numbering-machines now in use this manipulation of the figures could not be accomplished without very considerable delay and difficulty.

If found desirable, as may be found in the printing of such matters as railroad-tickets, &c., in one color, and with raised type or forms, the forms may be arranged upon or as a part of the top plate, so that the numbering and printing may be completed at one operation.

Wheels with index-letters and other characters or symbols may be introduced in connection with the numbering-wheels in the ordinary manner.

Having thus fully described my invention, what I claim as new, and desire to secure by Letters Patent, is—

1. In a machine for printing several series of numbers or other characters at one impression, the combination, with the printing-wheels, of simultaneously-operating ratchets, constructed substantially as shown and described, whereby the ratchets are adapted at

all times to move the several wheels of any one denomination independently of all the other wheels, for the purposes explained.

2. The combination of two or more numbering or printing heads with operating wheels and ratchets, connected substantially as shown and described, said ratchets serving to move all the wheels of one denomination simultaneously, but independently of all the other wheels, and also serving at all times to adjust misplaced or other desired figure-wheels without disturbing the wheels and ratchets corresponding to a different denomination, for the purposes explained.

3. The combination, with the several printing-wheels in a numbering-head, of a ratchet-bar located beneath each wheel, and adapted to turn its corresponding wheel forward or backward, at pleasure, but independently of all the other wheels, substantially as shown and described.

4. In combination with the operating-ratchets of a numbering or printing machine adapt-

ed to print a series of numbers or other characters at one impression, a stop-spring controlled by a movable key, substantially in the manner and for the purposes set forth.

5. In combination with the springs which arrest the motion of the operating-ratchets, a series of keys arranged alternately upon opposite sides of the movable ratchet, substantially as shown and described.

6. The combination, with the ratchet F, of two or more operating-wheels, E, mounted upon a single shaft, and the ratchet-bars D, resting upon said wheels, whereby said ratchet-bars are simultaneously moved, substantially as set forth.

In testimony that I claim the foregoing I have hereunto set my hand in the presence of two witnesses.

CHARLES EWING.

Witnesses:

GEO. F. GRAHAM,
CHARLES R. SEARLE.