

T. HODGSON.
Saw-Sharpening Machine.

No. 201,416.

Patented March 19, 1878.

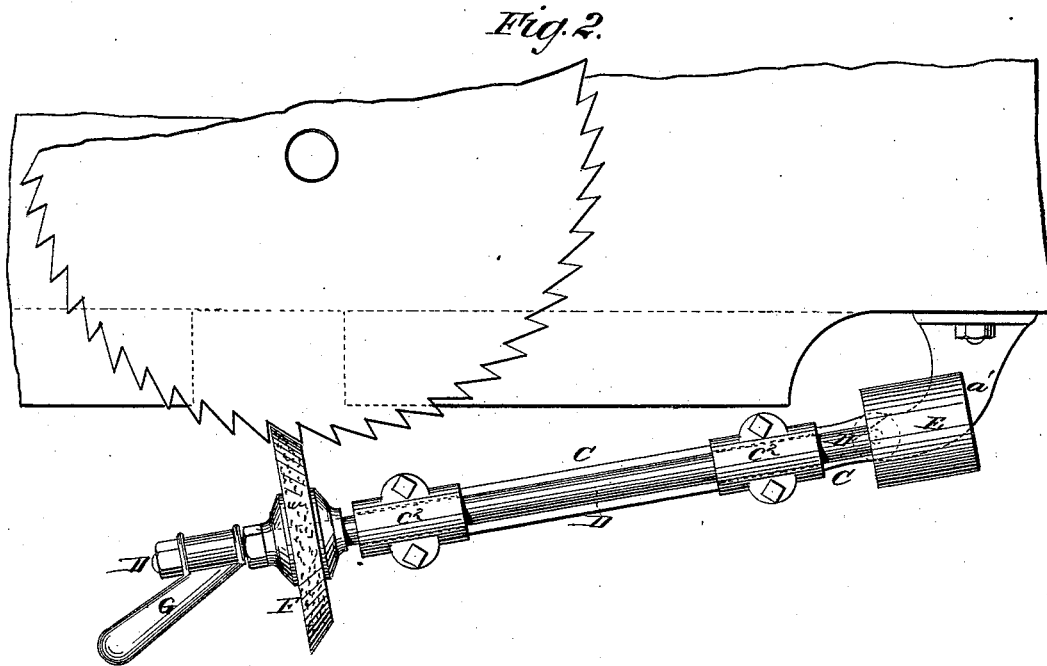
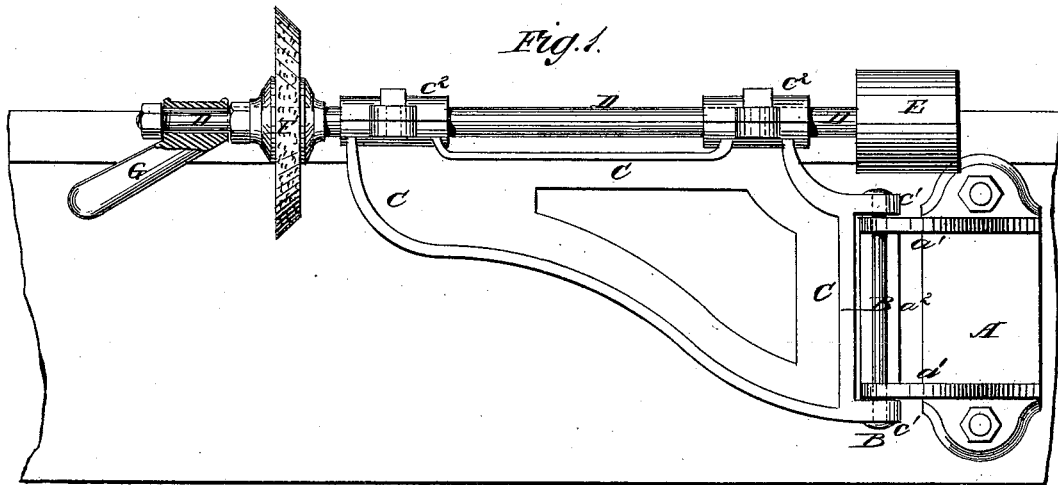

WITNESSES:
Francis McArdle
C. Sedgwick

INVENTOR:
T. Hodgson
BY *Almunt*

ATTORNEYS.

UNITED STATES PATENT OFFICE.

THADDEUS HODGSON, OF AMHERST, NOVA SCOTIA, CANADA.

IMPROVEMENT IN SAW-SHARPENING MACHINES.

Specification forming part of Letters Patent No. 201,416, dated March 19, 1878; application filed February 18, 1878.

To all whom it may concern:

Be it known that I, THADDEUS HODGSON, of Amherst, in the county of Cumberland, Province of Nova Scotia, and Dominion of Canada, have invented a new and useful Improvement in Saw-Grinders, of which the following is a specification:

Figure 1 is a front view of my improved machine, partly in section, to show the construction. Fig. 2 is a top view of the same.

Similar letters of reference indicate corresponding parts.

The object of this invention is to furnish an improved machine for gumming and sharpening saws, which shall be simple in construction, inexpensive in manufacture, easily guided and controlled, and effective in operation.

The invention consists in the combination of the plate, provided with the curved lugs, and the strengthening-bar, the pivoting-bolt, the pivoted arm, provided with the lugs and the bearings, and the sliding shaft provided with the pulley, the emery-wheel, and the handle, with each other, as hereinafter fully described.

A represents a plate, which is designed to be bolted to the front of the work-bench. Upon the upper and lower parts of the front of the plate A are cast two parallel lugs, a^1 , which are curved to one side, and have holes formed through their outer ends to receive the pivoting-bolt B. The lugs a^1 are connected at their outer ends by a bar, a^2 , cast upon them, so that each may be supported from the other.

C is an arm or bracket, upon the rear end of which are formed lugs c^1 , which are at such a distance apart as to overlap the lugs a^1 , and have holes formed through them to receive the bolt B, so as to hinge the said arm to the plate A.

Upon the upper edge of the arm C, at its outer and inner ends, are formed bearings c^2 , to receive the shaft D, which is made longer than the space between the bearings, so that it may have a longitudinal play in the said bearings.

To the inner end of the shaft D is attached a pulley, E, to receive the driving-belt, which may be driven from a shaft above or below the said pulley E, and which should be so arranged that the part of the driving-belt that is moving toward the said pulley E may be vertical. This arrangement of the driving-belt, and the arrangement of the pulley E over or nearly over the pivoting-bolt B, prevents the said driving-belt from running off; however much the shaft D may be slid in its bearings and the arm C swung upon its pivot.

To the shaft D, near its forward end and near the end of the arm C, is attached an emery-wheel, F, the face of which is so formed as to give the desired shape to the saw-teeth.

The outer end of the shaft D passes through and revolves in a socket in the inner end of the handle G, and has a nut screwed upon it to keep the said handle in place. The handle G enables the emery-wheel to be adjusted, guided, and controlled as may be required.

When a circular saw is to be ground, its eye is placed upon a pin attached to the work-bench, and upon which the said saw is turned to bring its teeth successively into position to be operated upon the emery-wheel.

When a straight saw is to be ground, it is laid upon the bench and moved longitudinally to bring its teeth successively into position to be operated upon by the emery-wheel.

Having thus described my invention, I claim as new and desire to secure by Letters Patent—

The combination of the plate A, provided with the curved lugs a^1 and the strengthening-bar a^2 , the pivoting-bolt B, the pivoted arm C, provided with the lugs c^1 and the bearings c^2 , and the sliding shaft D, provided with the pulley E, the emery-wheel F, and the handle G, with each other, substantially as herein shown and described.

THADDEUS HODGSON.

Witnesses:

J. WIEDLEY TOWNSHEND,
A. R. DICKEY.