

A. L. LARWILL.
Grapple.

No. 201,427.

Patented March 19, 1878.

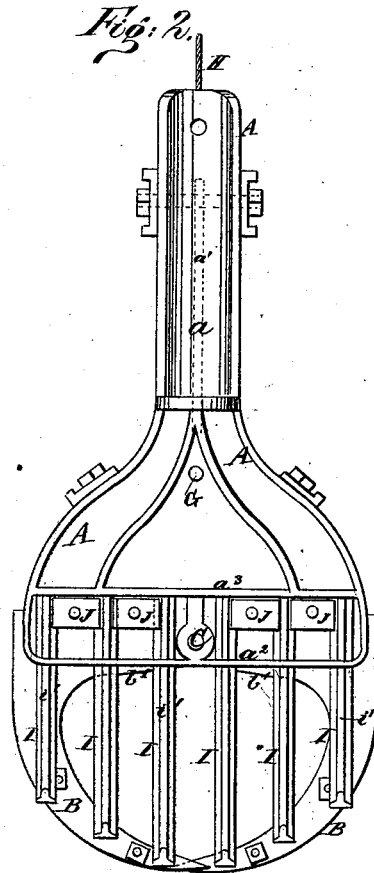
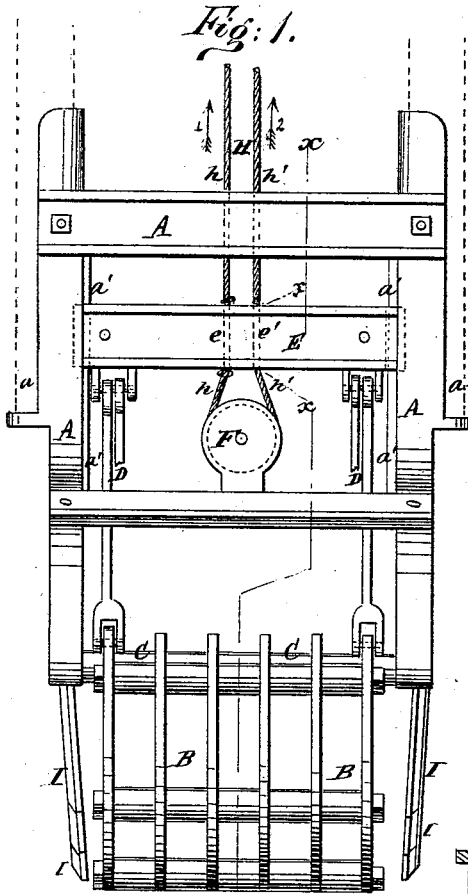
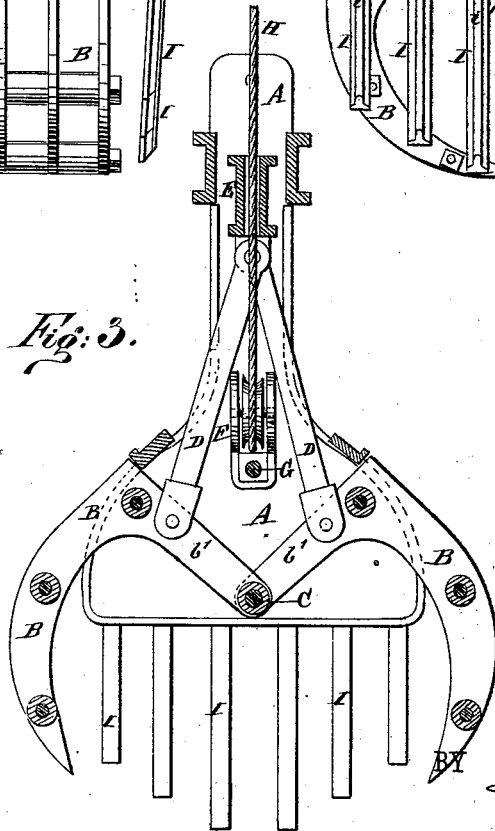

Fig. 3.



WITNESSES:

Chas. Nida
C. Sedgwick

INVENTOR:

A. L. Larwill
Mumford

ATTORNEYS.

UNITED STATES PATENT OFFICE.

ALFRED L. LARWILL, OF PORT ROYAL, ASSIGNOR TO HIMSELF AND GEORGE W. ROBERTS, OF BEAUFORT, SOUTH CAROLINA.

IMPROVEMENT IN GRAPPLES.

Specification forming part of Letters Patent No. **201,427**, dated March 19, 1878; application filed December 22, 1877.

To all whom it may concern:

Be it known that I, ALFRED L. LARWILL, of Port Royal, in the county of Beaufort and State of South Carolina, have invented a new and Improved Grapple, of which the following is a specification:

The object of my invention is to so improve the construction of grapples used for digging phosphate rock, or for other similar purposes, as to relieve the strain on the claws and bent arms of the same, and adapt it for cutting or separating from the rock at each dig or dip a suitable quantity to be embraced by its claws and raised to the surface of the water.

The invention consists in the combination, with a grapple, of one or more, or a series of, cutting-blades, bars, or chisels, for loosening or separating the rock, as will be hereinafter described.

In the accompanying drawings, Figure 1 represents a front view of my improved grapple. Fig. 2 is a side view of the same. Fig. 3 is a vertical section through the line $x x$ of Fig. 1.

Similar letters of reference indicate corresponding parts.

A is the frame of the grapple, provided with recesses and shoulders at a , for the attachment of the usual guide-rods by which the grapple is dipped and elevated. B are the two jaws or claws of the grapple, made and curved in the usual manner, and provided with the arms b' , which are bent off at right angles to the upper straight ends or bases of the claws, and by which they are pivoted on the central shaft C, secured with its ends at two opposite sides of the frame A. D are rods or links pivoted at their lower ends to the arms b' of the claws B, and at their upper ends with a common pivot to a lug on the cross-head E, which is fitted to slide on guides or ways a' on the frame A. F is a rope-pulley pivoted centrally underneath the cross-head E to a cross-bar, G, (or connection thereto,) secured to the frame A.

H is a rope or chain working on the pulley F for opening and closing the claws B. For this purpose one part, h , of the rope H is secured firmly to the cross-head E in a hole, e , made through the latter, and the other part h' (being the return part from the pulley F) slides loosely through another hole, e' , in the cross-head E.

By pulling the rope by the part h in the direction of arrow 1, the cross-head E will slide up on the ways a' , pulling the arms b' by the connecting-rods D and opening the claws B. By pulling the part h' of the rope in the direction of the arrow 2 the claws will be closed.

I are the chisels or cutters constituting the main point of my invention. In the drawing a series of these are shown at each side of the frame, extending across the whole opening of the claws B, and strengthened by being provided with ribs or feathers i' . They are fitted through suitable holes in the lower flange or web a^2 of the side frame, and made to butt with their upper ends against another web, a^3 , while being held and pressed to the side frame, for the prevention of any lateral deviation by the plates or cleats J, interposed between the ribs i' of each pair of them and riveted or bolted to the frame.

I do not, however, confine myself to any particular number, form, position, or mode of fastening, or size of the cutters or chisels I, as the grapples may be made with a single cutter extending all or part of the space across the opening of the claws or parallel with said opening, or may be made with bars or points, or otherwise, so long as they serve for the said purpose of striking, cutting, and breaking the rock or like material, thereby lessening the strain on the claws B and arms b' , making them less liable to be bent out of shape or broken. I prefer, however, the form shown, in which the chisels cut on two parallel lines, loosening from the rock the intervening surface to be grasped by the claws B.

Having thus described my invention, I claim

as new and desire to secure by Letters Patent—

1. The combination, with hinged claws B, of the side frames having chisel-cutters I, arranged to operate as and for the purpose described.

2. The cleats J, in combination with the

feathered chisels I, and with the frame A, provided with webs $a^2 a^3$, substantially as and for the purpose specified.

ALFRED LANGDON LARWILL.

Witnesses:

P. B. MORRIS,
SHEPARD D. GILBERT.