

E. D. LEAVITT, Jr., & W. JONES.
Steam Cylinder with Steam Jacket.

No. 201,429.

Patented March 19, 1878.

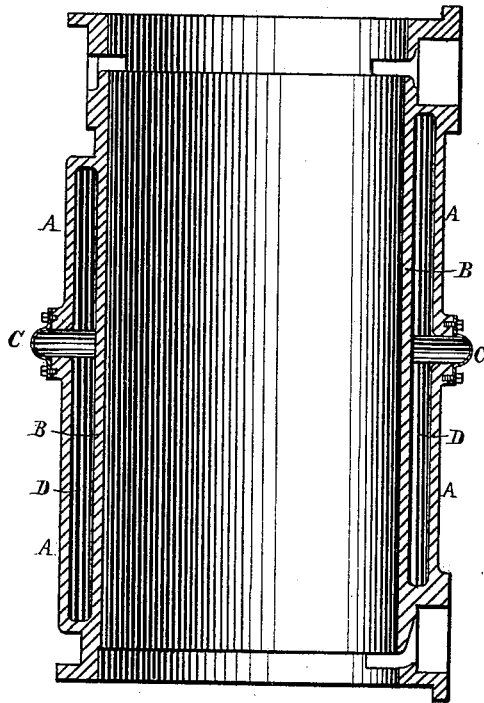

WITNESSES.

E. A. Kemmenway
G. H. Dodd

INVENTOR.

Wm. Hubbard Atty for
E. D. Leavitt Jr. & Washington Jones

UNITED STATES PATENT OFFICE.

ERASMUS D. LEAVITT, JR., OF CAMBRIDGE, MASSACHUSETTS, AND WASHINGTON JONES, OF PHILADELPHIA, PENNSYLVANIA.

IMPROVEMENT IN STEAM-CYLINDERS WITH STEAM-JACKETS.

Specification forming part of Letters Patent No. **201,429**, dated March 19, 1878; application filed January 15, 1878.

To all whom it may concern:

Be it known that we, ERASMUS D. LEAVITT, Jr., of Cambridge, in the county of Middlesex and State of Massachusetts, and WASHINGTON JONES, of Port Richmond Iron Works, in Philadelphia, in the State of Pennsylvania, have invented an Improvement in Casting Steam-Cylinders with Steam-Jackets; of which the following is a specification:

In the casting of steam-cylinders of considerable size which are made with a "steam-jacket," so-called, (which is an annular chamber extending entirely around the cylinder which contains the bore in which the piston works, and in which the steam is admitted to heat the cylinder,) the making of the cylinder proper and the jacket in one continuous casting, as is usually done, renders the casting, which is of considerable size and weight, and somewhat complicated, liable to be broken across the interior part, or cylinder proper, by the unequal shrinking of the metal in cooling, which frequently spoils the cylinder after it has left the hands of the mechanist by its unequal expansion and shrinkage in use.

This invention is for the purpose of obviating this difficulty; and it consists in making the outer wall of the jacket discontinuous, leaving an annular space entirely around the circumference, and joining the two parts of the jacket by a solid "expansion-joint," so-called, which makes an impervious inclosure of the steam-space of the jacket, and by its slight elasticity prevents the possibility of establishing any undue strain of the parts by the heating or shrinking of the metal.

The drawing represents a steam-cylinder

made with a jacket cast on it and an expansion-joint attached to it.

A is the outer wall of the jacket, and B the wall of the cylinder-bore. C is the expansion-joint, which connects the two parts of the jacket, and thus makes the entire wall of the jacket in effect continuous, while, by its slight flexibility or yielding capacity, it prevents the existence of undue strain in the wall of the cylinder proper or of the jacket by shrinkage.

When the cylinder is cast an annular space, D, is left open entirely around the cylinder, which entirely relieves the cylinder proper or the jacket of any lengthwise strain in cooling, and on either side of this space a belt is formed upon the jacket, upon which the expansion-joint C is fitted by boring and turning with a steam-tight joint, and is further secured thereto by bolting it to the belts, as shown.

This expansion-joint is, by preference, made of copper, or some metal that will not break by the slight flexure to which it is subjected.

We do not claim casting the steam-cylinder with its jacket in one piece, nor the use of an "expansion-joint," so-called, to avoid the effect of expansion by heat of two separate parts so connected, as they are both old and well-known devices.

We claim—

The combination of an expansion-joint with the steam-jacket when the jacket and cylinder are cast in one piece.

E. D. LEAVITT, JR.
WASHINGTON JONES.

Witnesses:

MORTON MORRIS,
ALBERT E. DOWNS.