

A. J. LYTLE.  
Button-Hole Cutters.

No. 201,432.

Patented March 19, 1878.

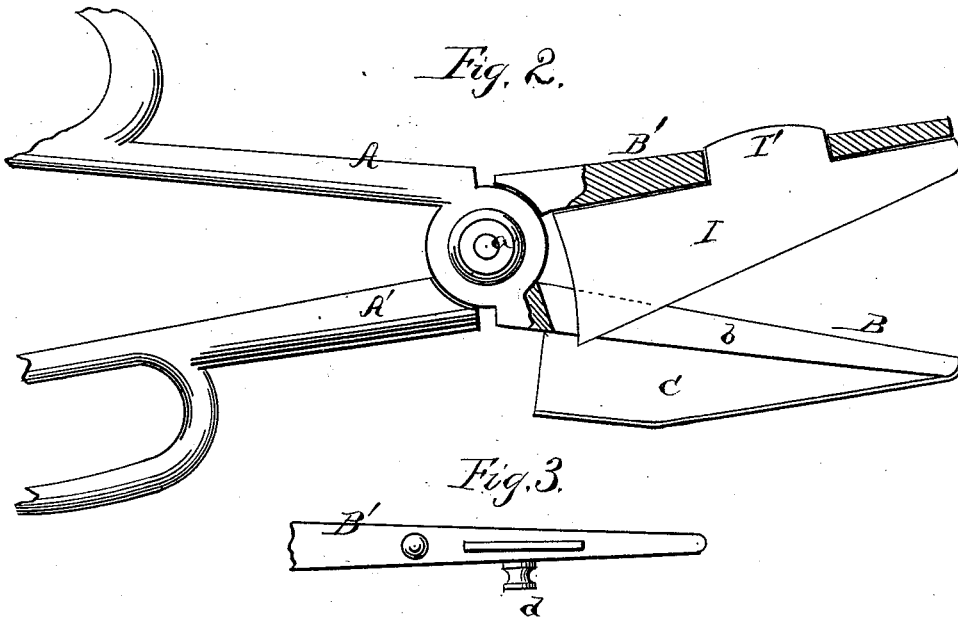
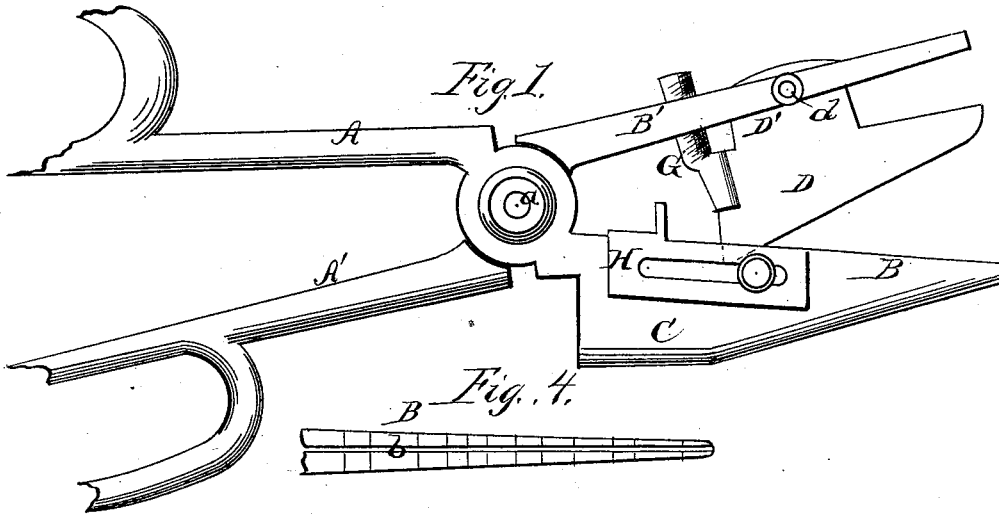

Witnesses:

H. C. Arthur  
C. F. Ewert

Inventor  
A. J. Lytle,

per

J. H. Alexander & Bellroth,  
Attorneys.

# UNITED STATES PATENT OFFICE.

ANDREW J. LYTLE, OF HILLSBOROUGH, OHIO.

## IMPROVEMENT IN BUTTON-HOLE CUTTERS.

Specification forming part of Letters Patent No. **201,432**, dated March 19, 1878; application filed August 22, 1877.

### *To all whom it may concern:*

Be it known that I, A. J. LYTLE, of Hillsborough, in the county of Highland and State of Ohio, have invented certain new and useful Improvement in Shears and Button-Hole Cutters; and I do hereby declare that the following is a full, clear, and exact description thereof, reference being had to the accompanying drawings, and to the letters of reference marked thereon, which form part of this specification.

The nature of my invention consists in the novel construction, combination, and arrangement of parts in a combined shears and button-hole cutter, as will be hereinafter more fully set forth and definitely claimed.

In order to enable others skilled in the art to which my invention appertains to make and use the same, I will now describe its construction and operation, referring to the annexed drawing, in which—

Figure 1 is a side view of my invention arranged as a button-hole cutter. Fig. 2 is a longitudinal section, showing it as ordinary shears. Figs. 3 and 4 are views of detailed parts thereof.

A A' represent the two handles, pivoted together at *a*, and formed with the jaws B B', respectively. The jaw B is slotted longitudinally, as shown at *b* in Figs. 2 and 4, and is formed with a hollow casing, C, on its outer side, made tapering, closed at the front, and open at the rear. The inner face of the jaw B is graduated, so as to set a gage, hereinafter described, for cutting button-holes the exact length required.

The jaw B' has a central slot for the insertion of a shank, D', formed on a shear-blade or cutter, D, which is held by means of a set-screw, *d*. This cutter is especially intended for use in cutting button-holes, and in connection therewith is used a tubular cutter, G, screwed into the jaw B' from the inner side. The front of the tubular cutter G is slotted,

and the back edge of the straight cutter D enters this slot.

It will readily be seen that when the shears are closed the tubular cutter G makes the round portion of the button-hole, and the straight cutter D makes the slit thereof. The length of this slit is gaged by the position of the two cutters, for the tubular cutter also acts as a stop in closing the shears, and the straight cutter can therefore not make any longer slit than said tubular cutter will permit according to its adjustment in the jaw.

On the jaw B is attached a slotted gage, H, fastened by a set-screw, *f*, for regulating the distance of the button-hole from the edge of the goods, and cause such distances to be uniform.

When the implement is to be used as shears alone the cutters D and G are removed, and a blade, I, with shank I', is inserted, and held in the jaw B' by the set-screw *d*. In either case the straight cutter, as it passes through the slot in the jaw B, enters the casing C and is concealed thereby, so as to protect the person using the implement from being injured thereby.

Having thus fully described my invention, what I claim as new, and desire to secure by Letters Patent, is—

In a button-hole cutter, an adjustable straight blade or cutter, D, provided with a shank, D', inserted in a mortise in one jaw of the shears, and held by a set-screw, *d*, in combination with the tubular adjustable cutter G, slotted jaw B, and adjustable gage H, all constructed substantially as and for the purposes herein set forth.

In testimony that I claim the foregoing as my own invention I affix my signature in presence of two witnesses.

A. J. LYTLE.

Witnesses:

J. B. HAWK,  
S. E. PARKER.