

A. REICHENBACH. Knitting Machine.

No. 201,447.

Patented March 19, 1878.

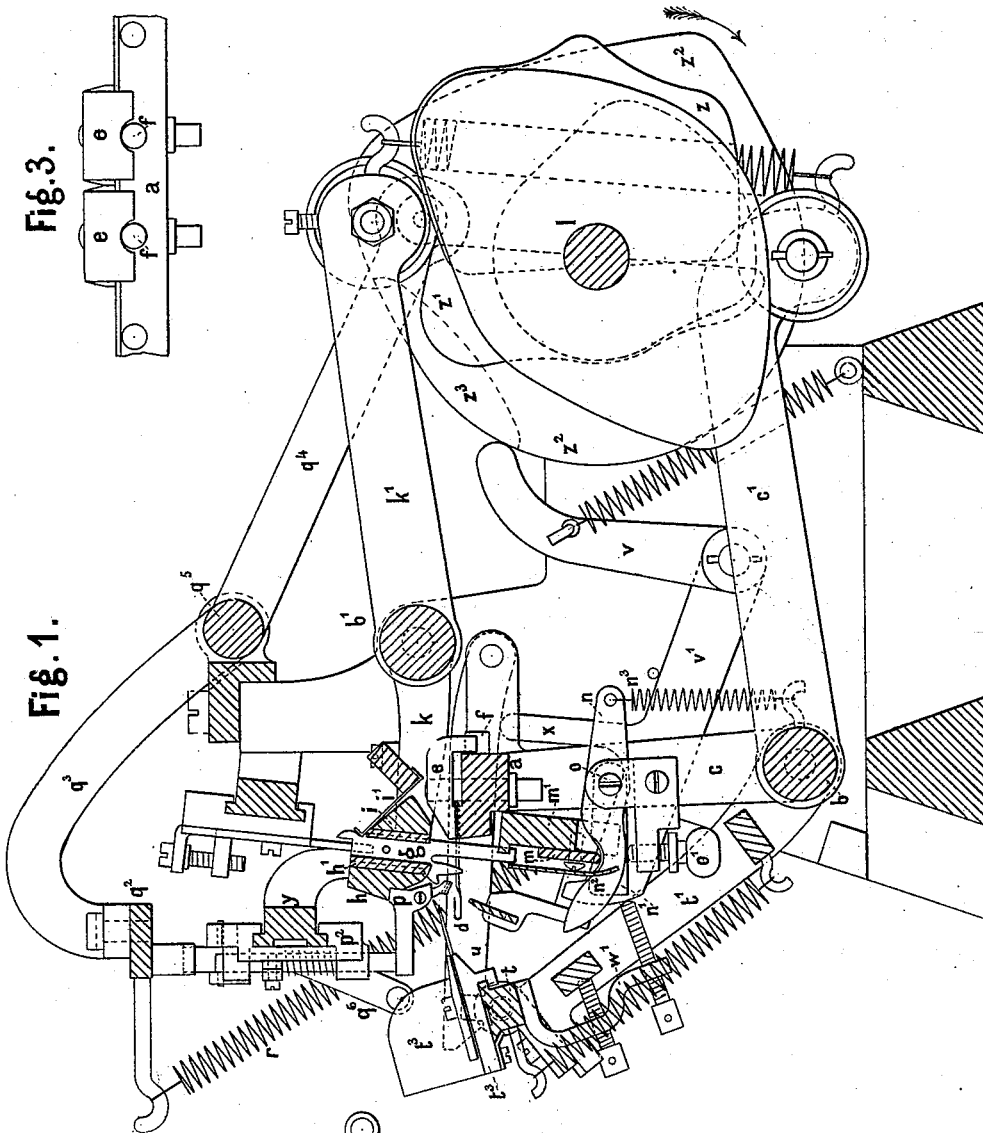

Fig. 3.

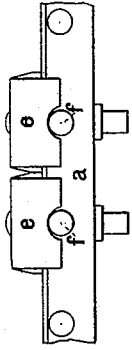
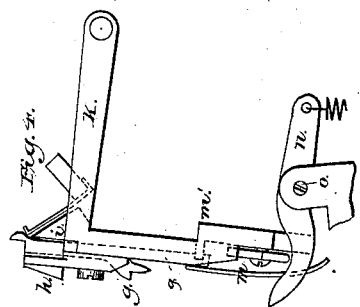

Fig. 1.

Attest
 Geo. H. Graham
 W. C. Haspe.



Inventor,
 A. Reichenbach,
 by Munson & Philipp.

Attorneys.

A. REICHENBACH.
Knitting Machine.

No. 201,447.

Patented March 19, 1878.

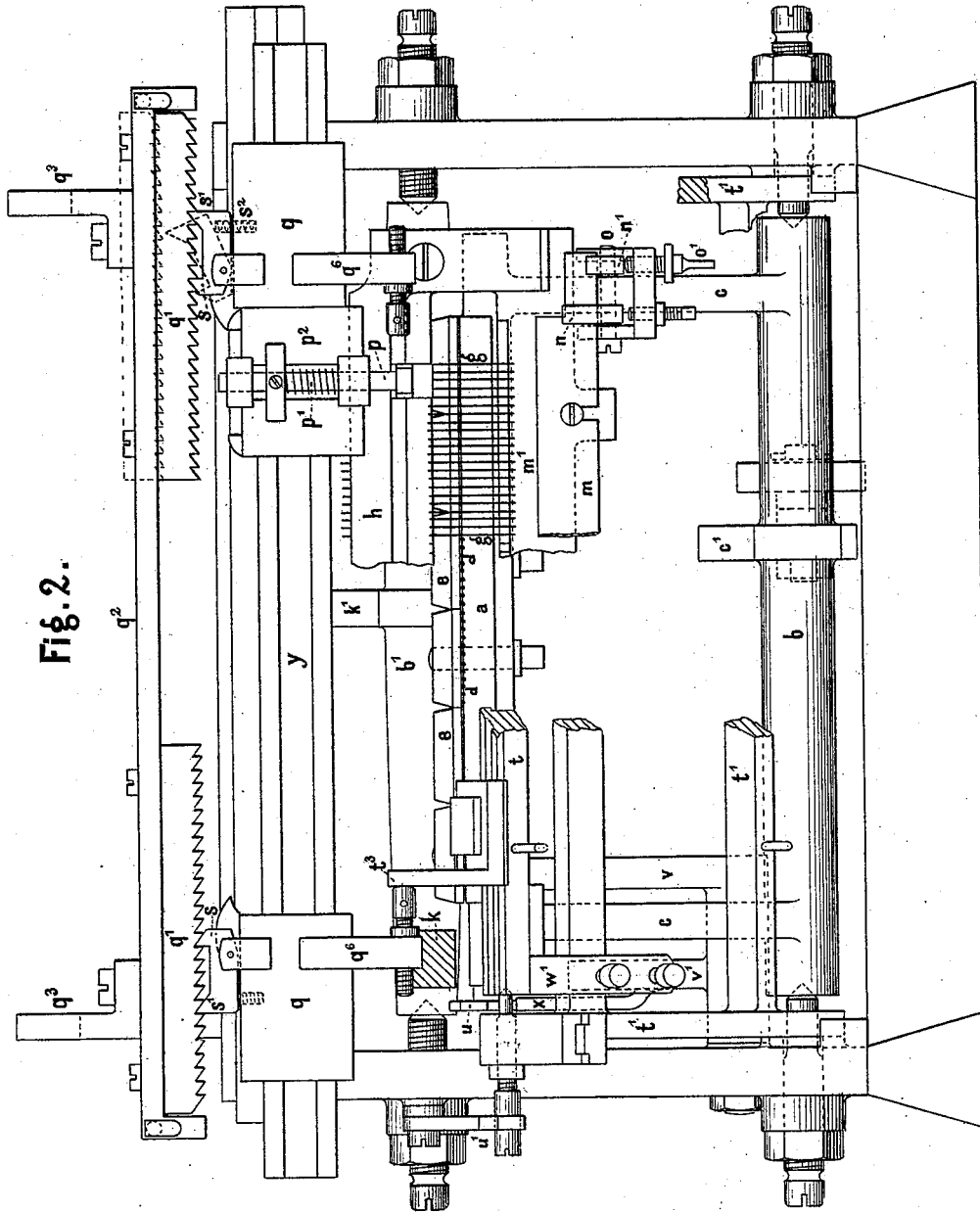

Fig. 2.

Attest:
Geo. H. Graham.
W. C. Haspe.

Inventor:
A. Reichenbach,
by *Munson & Phillips*,
Attorneys.

UNITED STATES PATENT OFFICE.

ADOLF REICHENBACH, OF LIMBACH, NEAR CHEMNITZ, ASSIGNOR TO GUSTAV HEINRICH NEUMANN, OF OEDERAN, NEAR CHEMNITZ, SAXONY.

IMPROVEMENT IN KNITTING-MACHINES.

Specification forming part of Letters Patent No. 201,447, dated March 19, 1878; application filed December 13, 1877; patented in Saxony, June 1, 1877, for five years.

To all whom it may concern:

Be it known that I, ADOLF REICHENBACH, of Limbach, near Chemnitz, Saxony, have invented an Improved Knitting-Machine, of which the following is a specification:

This invention relates to certain improvements in straight-knitting machines, by which important advantages are attained over other machines of the kind.

Figure 1 of the accompanying two sheets of drawings represents my improved machine in a transverse section, while Fig. 2 is a front view of the same, and Fig. 3 a back view of the needle-bar.

Several parts, which are not to be considered as new, have been omitted, and in Fig. 2 a number of parts have been represented broken off, so as to show others lying in their rear.

The bar *a*, carrying the frame-needles *d*, is fixed on two arms of a rocking shaft, *b*, which is actuated by the cam *z* and the lever *c'*. The needle-bar consequently oscillates horizontally in a short arc of a circle, instead of moving backward and forward in a straight line, as is frequently the practice.

The frame-needles *d* are fastened to the needle-bar in series of (by preference) from five to ten by the covering-plates *e*, each of which rests at the back on a stud or projection, *f*, of the needle-bar, Figs. 1 and 3, so that upon being screwed down its front edge will bear equally on all the needles of its series, and secure them firmly to the needle-bar.

The sinkers *g* are guided between two bars, *h* and *i*, constituting the sinker-frame, which is fastened to the arms *k* of the shaft *b'*. This shaft is oscillated by the cam *z'*, acting on the arm *k'*. The sinker-frame, instead of reciprocating up and down in a straight line, as usual, is by consequence moved in a short arc of a circle.

The guide-bar *h* presses near the end of its descent on the beards of the frame-needles, so as to close them, whereby a special presser-bar is dispensed with.

By preference the bars *h* and *i* are lined on the inside with brass plates, and in this case the lining-plate *h'* may be arranged to act on the needles, as shown in the drawing.

The bar *m*, which corresponds to the falling-bar of other knitting-machines, is used here also as a sinker-lifting bar. The same is guided on the bar *m'*, forming part of or attached to the sinker-frame, as more clearly shown in Fig. 4 of the drawing, and it is lifted during the back stroke of the needle-bar by the incline *n²* on the front end of the two levers *n*. These levers are pivoted at *o* to the arms *c*, and the springs *n³* serve to keep them in their acting position, while they allow them to yield to an accidental undue strain.

The descent of the bar *m* is limited by the two stops *n¹*, also pivoted at *o*, which can be adjusted by the screws *o'*, for the purpose of regulating the machine with regard to the desired closeness of the fabric.

The lifting-bar *m* raises the sinkers *g* after they have sunk down the loops between the needles. As soon, however, as the levers *n* move forward again the inclines *n²* allow the lifting-bar *m* to redescend until it rests on the stops *n¹*. The sinkers are, however, kept in their upper position by the springs *v'* catching into the notches of the sinkers.

The thread-guide holder *p* is free to slide vertically in the saddle *p²*, within which a spring, *p¹*, presses it upward, so that it bears with its foot against an edge of the bar *h*. The saddle *p²* slides horizontally on the bar *y*, fixed to the frame of the machine. As the sinker-frame approaches the end of its downward stroke the thread-guide is pressed down between the selvage-needles, while it rises with its holder *p* by the action of the spring *p¹* as soon as the sinker-frame reascends.

The saddle *p²* is actuated in the usual manner, and its course is limited by the adjustable stops *q*, Fig. 2, as in former machines; but the position of the stops is regulated by a new device, which will be described hereinafter.

The narrowing apparatus consists of the tickler-bar *t*, pivoted to the frame *t'*, which oscillates on the pivots of the shaft *b*; moreover, of the lever *v v'*, actuated by the cam *z²* of a hook, *u*; and, finally, of a mechanism for shifting the shaft *l* longitudinally.

Whenever narrowing is required, the main shaft *l* is shifted lengthwise, together with the

cams keyed on the same, as is usual in this class of machines. The cam z^2 now acts on the lever v , so as to cause the finger x of this lever to descend. In consequence, the hook u , being no more supported, catches with its notch on the pivot of the tickler-bar t . The narrowing apparatus thereby becomes connected with the needle-bar, so that both swing to and fro together. At its first forward oscillation the tickler-bar is drawn toward the sinker-frame. At the same time the end of the lever v' , acting on the arm w' of the tickler-bar, causes this bar to turn on its pivots, and to press the narrowing-needles on the frame-needles d , so as to make them enter into the corresponding loops on the latter. By the backward oscillation of the tickler-bar these loops are drawn off from the frame-needles, the narrowing-needles are shifted by the stops q when the tickler-bar is near the end of its back stroke, and at its following oscillation the loops are taken off from the narrowing-needles by the sinkers and retained on the frame-needles.

The shifting of the shaft l lengthwise, as before specified, causes the cam z^3 , attached to the cam-disk z^2 , to be brought into operation on the lever q^4 , so as to oscillate the shaft q^5 , and to make its two arms, q^3 , rise together with the bar q^2 , having a rack, q^1 , at either end. Each of these racks acts on a pawl, s s^1 , pivoted to the adjustable stop q . One end of the said pawl is pressed upward by a spring, s^2 , while an inclined tooth at either end catches into the nicks of the rack. The latter being lifted, the springs s^2 raise the ends s^1 of the pawls s s^1 and cause them to swing in a circle, in consequence whereof their teeth s^1 catch into the next nicks of the racks, as shown by dotted lines in Fig. 2. The racks being now depressed by the action of the two springs r , Fig. 1, both stops q are shifted toward the middle of the frame. After the shifting they are held securely in their place, as both teeth of the pawl s s^1 catch into the racks, thus preventing the pawls from turning.

The described movement of the stops q is transmitted by the arms q^6 to the slides t^3 , carrying the narrowing-needles, after these needles have receded from the frame-needles by the oscillation of the tickler-bar t . In consequence the loops on the narrowing-needles are brought opposite to frame-needles contiguous to those on which they were originally formed. The tickler-bar thereupon making the second forward oscillation, the loops are transferred, as has been stated above.

While the work is going on without narrowing, the cam z^2 is out of the way of the lever v , so that the latter is at rest. Conse-

quently the finger x keeps the hook u raised and the narrowing apparatus disconnected from the needle-bar. The said apparatus is retained in its non-acting position by a hook, u' , Fig. 2, fixed to the framing, so as to cause the needles to stand above the frame-needles d , and not to interfere with other working parts.

I am aware that in straight-knitting machines it is old to use a needle-bar having the needles clamped therein by bars in sections, which bar is moved in the arc of a circle; to use a vibrating sinker-frame in which the sinkers are carried, one part of which acting as a presser-bar to close the beard of the frame-needles; to use adjustable stops actuated by racks and pawls, and actuating, through bars, slides carrying narrowing-needles on a tickler-bar; and to move lengthwise the shaft carrying the actuating-cams; and I therefore make no claim, broadly, to any of said devices; but

What I do claim as of my invention, and desire to secure by Letters Patent, is—

1. In combination with the needle-bar a , provided with projections or studs f , needles, and covers e , each cover resting at the back on one of said studs or projections, as and for the purpose described.

2. The sinker-frame h i and sinkers guided therein, in combination with the shaft b' , a cam, z^1 , and arms k k' , as and for the purpose specified.

3. The sinker-lifting bar m , in combination with the levers n , provided with the inclines n^2 , and the stops n^1 , adjustable by screws o' , substantially as described, and for the purpose stated.

4. The sinker-guide bar h , in combination with the thread-guide holder p , the saddle p^2 , and spring p^1 , as and for the purpose described.

5. The adjustable stops q and the saddle p^2 , in combination with the racks q^1 and mechanism for operating the latter, the pawls s s^1 , having two teeth each, and the springs s^2 , substantially as specified, and for the purpose stated.

6. The racks q^1 , mechanism, substantially as described, for operating the same, the pawls s s^1 , and the adjustable stops q , having the arm q^6 , in combination with the slides t^3 on the tickler-bar t , as and for the purpose specified.

In witness whereof I have signed my name to this specification in the presence of two subscribing witnesses.

ADOLF REICHENBACH.

Witnesses:

PAUL KASTEN,
PAUL DRUCKSMILLSE.