

J. W. PEARSON.
Harrow.

No. 201,554.

Patented March 19, 1878.

Fig. 1

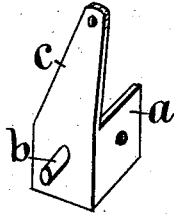

Fig. 2

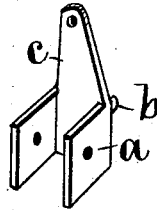
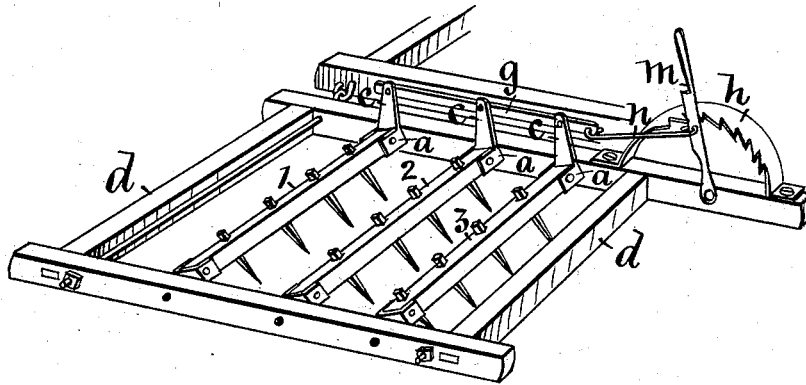

Fig. 3



Witnesses:
Frank W. Kuss.
R. G. Orwig.

Inventor:
John W. Pearson,
By Thomas G. Orwig,
Attorney.

UNITED STATES PATENT OFFICE.

JOHN W. PEARSON, OF DES MOINES, IOWA.

IMPROVEMENT IN HARROWS.

Specification forming part of Letters Patent No. **201,554**, dated March 19, 1878; application filed September 26, 1877.

To all whom it may concern:

Be it known that I, JOHN W. PEARSON, of Des Moines, in the county of Polk and State of Iowa, have invented an Improved Harrow, of which the following is a specification:

My invention relates to that class of drag-harrows in which the teeth are carried by rocking bars that can be readily adjusted to set the teeth at various angles relative to the ground.

It consists in providing metal sockets for the ends of the wooden rock-bars, that have gudgeons and arms formed integral therewith, and projecting therefrom, as required to mount and operate the bars in the harrow-frame, in the manner hereinafter fully set forth.

Figure 1 of my drawing is a perspective view of my combined rock-bar socket, arm, and gudgeon. Fig. 2 shows the same in a reversed position. Together they fully illustrate its form and construction.

a represents the socket. It may be angular and open at the top and bottom, as shown, or it may be closed and cylindrical in form. It may vary in size, as required to suit different sizes of wooden rock-bars designed to be inserted. *b* is a gudgeon projecting outward from the closed end and center of the socket *a*. *c* is an arm projecting upward from the top side of the closed end of the socket *a*. The parts *a b c* are all cast together to form one complete piece.

Fig. 3 is a perspective view of my improved harrow, and illustrates the application and operation of my combined rock-bar sockets, gudgeons, and arms.

d d represents a rigid harrow-frame. 1 2 3 4 is a series of teeth-bearing rock-bars, mounted in the frame by means of my sockets *a b c*, fixed on their inner ends, and the gudgeons *b* being placed in bearings formed in the side pieces of the frame. Similar sockets, without

arms, are used on the outer ends. *g* is a vibrating bar, to which the top end of each arm *c* is pivoted. *h* is a rack rigidly fixed to the rear extension of the harrow-frame. *m* is a hand-lever, pivoted to the same part of the harrow-frame. *n* is a rod connecting the vibrating bar *g* and the hand-lever *m*. The hand-lever is suitably shaped to engage the rack *h*.

Two corresponding wings of a harrow are preferably hinged together by means of rods or eyebolts, or in any suitable way, to form a complete harrow.

In the practical operation the harrow-teeth can be readily controlled by means of the arms *c* of the rock-bar sockets being connected with the vibrating bar *g* and the lever *m*. By adjusting the lever in the rack *h* the teeth in the rocking bars are readily set to incline forward or backward at any angle desired, and as may be necessary to suit the varying conditions of the ground over which the harrow is advancing. By freeing the lever *m* from the rack *h* while advancing, the teeth will naturally turn rearward, and by so doing they can readily be passed over obstructions, and also cleaned from weeds and clogging matter that may have gathered and adhered thereto.

I claim as my invention—

1. In the construction of a harrow, the rock-bar socket *a*, having a gudgeon *b*, and an arm, *c*, formed integrally therewith, substantially as and for the purposes shown and described.

2. The bar-sockets *a b c*, each rigidly fixed to the end of a rock-bar carrying harrow-teeth, in combination with the rigid harrow-frame *d d* and the operating mechanism *g h m n*, substantially as and for the purposes shown and described.

JOHN W. PEARSON.

Witnesses:

I. M. SHUCK,
D. F. CALLENDER.