

G. H. SPAULDING. Harvester.

No. 201,563.

Patented March 19, 1878.

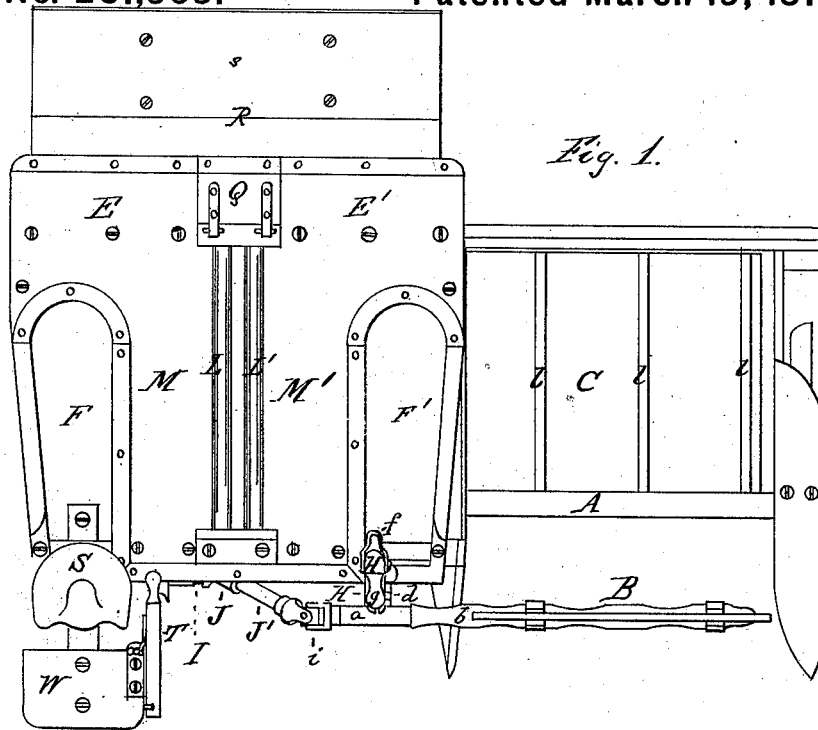

Fig. 1.

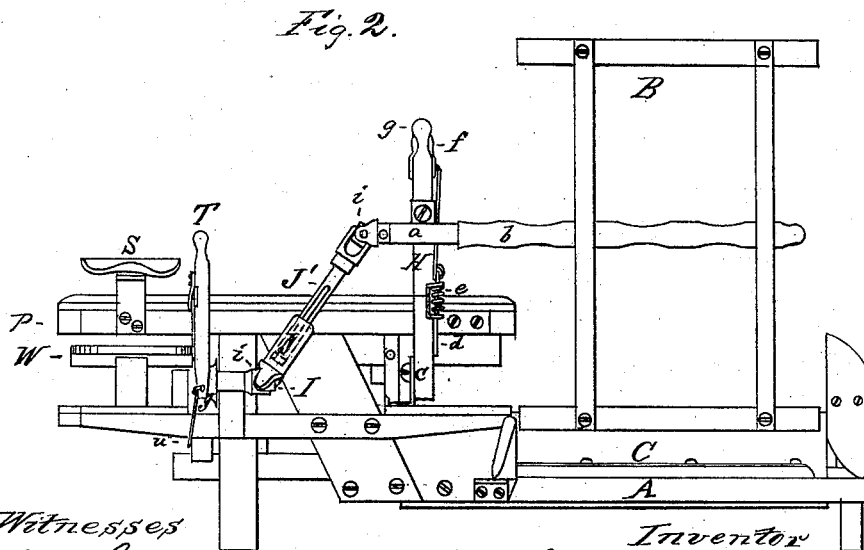

Fig. 2.

Witnesses
H. L. Bennett.
W. H. Isaacs.

Inventor
George Henry Spaulding
 by his *Att'y*
C. J. Penwick

G. H. SPAULDING.
Harvester.

No. 201,563.

Patented March 19, 1878.

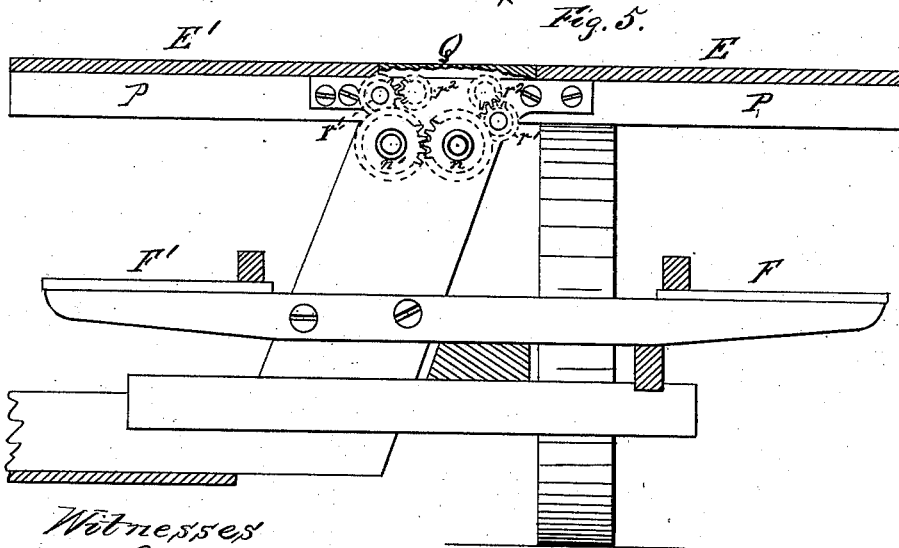
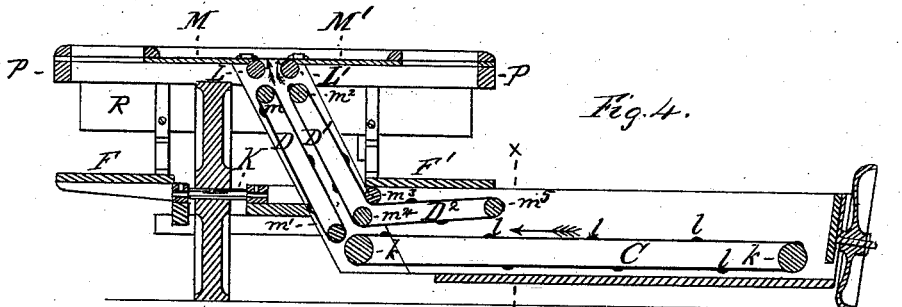
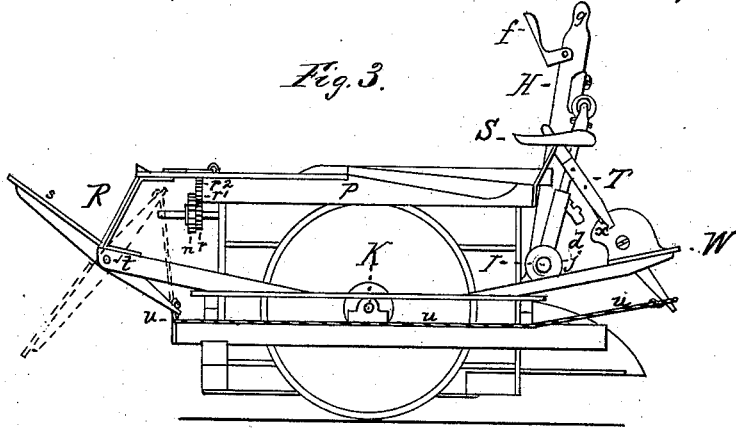

Witnesses
H. L. Bennett,
W. H. Isaacs.

Inventor
George Henry Spaulding
 by his atty
E. S. Kenwick

G. H. SPAULDING.
Harvester.

No. 201,563.

Patented March 19, 1878.

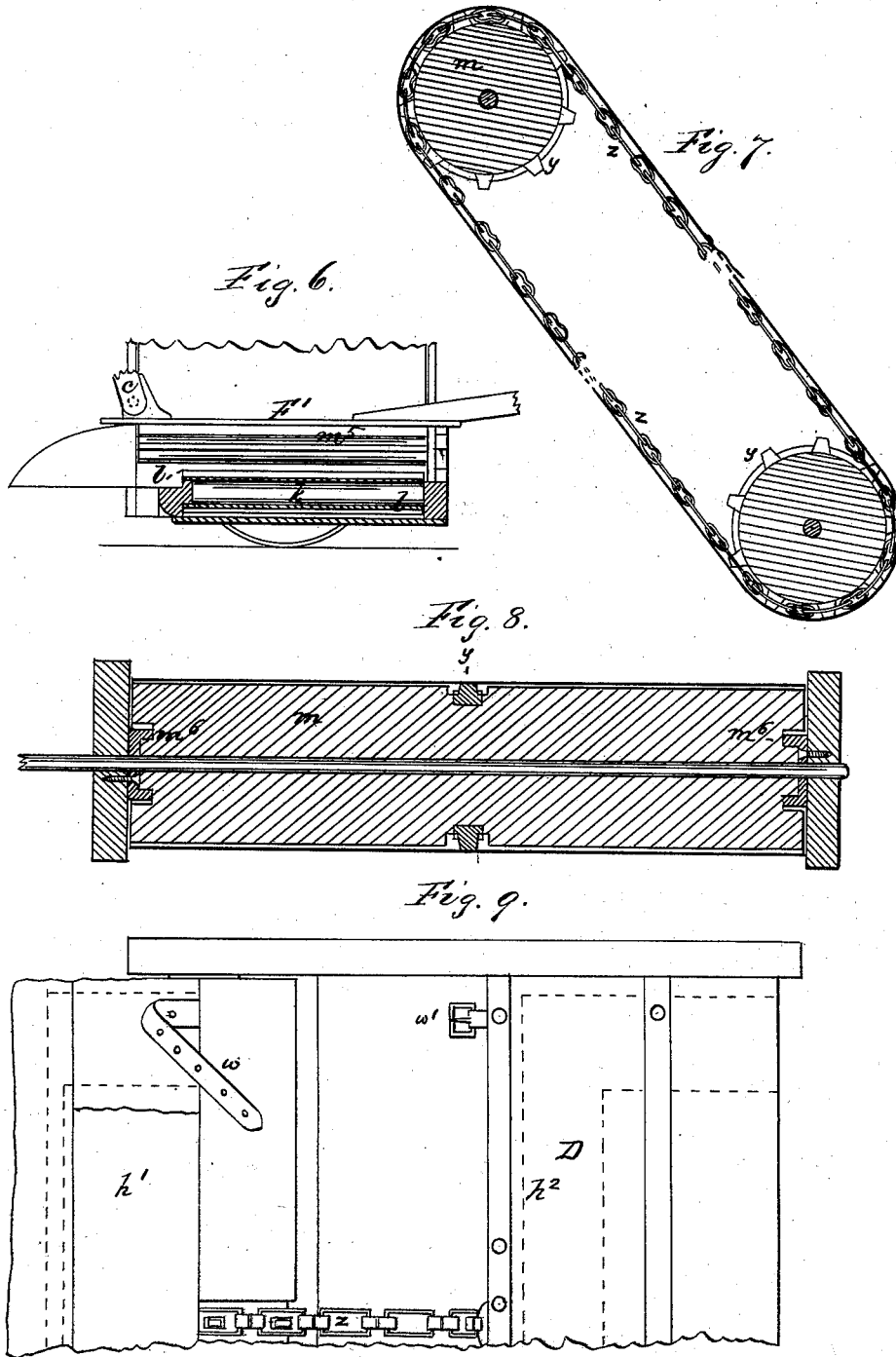

Witnesses
H. L. Bennett.
W. H. Isaacs.

Inventor
George Henry Spaulding
by his atty
C. S. Fenwick

UNITED STATES PATENT OFFICE.

GEORGE H. SPAULDING, OF ROCKFORD, ILLINOIS, ASSIGNOR OF ONE-HALF HIS RIGHT TO WM. A. KNOWLTON, OF SAME PLACE.

IMPROVEMENT IN HARVESTERS.

Specification forming part of Letters Patent No. **201,563**, dated March 19, 1878; application filed February 5, 1877.

To all whom it may concern:

Be it known that I, GEORGE HENRY SPAULDING, of Rockford, in the county of Winnebago and State of Illinois, have made an invention of certain new and useful Improvements in Harvesters; and that the following is a full, clear, and exact description and specification of the same.

The improvements which constitute the subject-matter of this patent have reference more particularly to that class of harvesters in which the grain is bound into sheaves upon the machine; but some of the improvements may be used for other purposes to which they are applicable.

The improvements consist of certain combinations of mechanical devices; and their objects are to facilitate the conveyance and delivery of the grain to elevating mechanism; to improve the operation of grain-elevating mechanism; to economize the space occupied by the binders, and to facilitate the delivery of the sheaves to the ground.

The combinations by means of which these objects are attained are set forth in detail at the close of this specification. In order that they may be fully understood, I have represented in the accompanying drawings, and will proceed to describe, such parts of a binder-harvester as are necessary for that purpose.

Figure 1 of the said drawings represents a plan of the said parts of a harvester. Fig. 2 represents a front elevation of the same. Fig. 3 is an end elevation of the same. Fig. 4 is a section of the same crosswise of the line of draft. Fig. 5 is a view of a part of the rear of the machine with the sheaf-carrier and parts of the binders' tables removed. Fig. 6 is a cross-section of a part of the machine at the line *x x* of Fig. 4. Figs. 7, 8, and 9 are views of parts of the machine disconnected from the residue.

The general arrangement of the machine is substantially the same as that of binder-harvesters hitherto made, the machine having a finger-beam, A, to which the usual cutting apparatus (composed of slotted guard-fingers and a reciprocating scalloped cutter) is secured. The grain to be cut is pressed toward the cut-

ting apparatus by a revolving reel, B. The cut grain is received upon a collecting-conveyer, C, by means of which it is conveyed to a duplex elevator, D D'. The grain is elevated to the level of tables E E', upon which it is bound into sheaves by binders, who stand upon suitable binders' supports or foot-boards F F'. The bound sheaves are placed by the binders upon a sheaf-carrier, R, at the rear of the machine, from which they are dropped at intervals to the ground.

In harvesters it is expedient to adjust the position of the reel to the condition of the grain to be cut. In order to enable the adjustment to be made while the machine is in operation, the box or bearing *a*, in which the shaft *b* of the reel turns, is supported by a reel-standard, H, which is connected at its lower end *c* with the frame of the machine by means of a hinge joint or pivot, so that the reel may be adjusted by moving the standard on its pivot.

In order that the reel may be held in the position to which it is adjusted, a rack-segment, *d*, is secured to the main frame, and a spring-bolt, *e*, to the adjustable reel-standard, so that the bolt may be engaged with one or other of the notches of the rack-segment to hold the reel as desired.

In order that the bolt may be readily disengaged from the rack-segment, the bolt is connected with a handle, *f*, at the upper end of the reel-standard H, which also has a handle, *g*, formed upon it, so that the reel-standard and bolt may be simultaneously manipulated by the hand of an operator.

Any other suitable holding device may be substituted in place of the rack-segment and bolt.

In order that the reel may be driven in whatever position it may be set or adjusted, and that the adjustment of the reel may not materially affect the driving of it, the reel is connected with the reel counter-shaft I by means of a flexible and extensible connection, consisting in this example of telescopic shafting J J', having universal joints *i i*, which supply the requisite flexibility. The reel counter-shaft I is fitted with a belt-pulley, *j*, to which power is transmitted by means of a

belt from a driving-pulley secured to the driving-shaft K of the machine, which, as usual, has the main running-wheel mounted upon it. The flexible connection may be varied as circumstances or the views of different constructors render expedient.

The grain, as it falls after cutting, is received upon the collecting-conveyer C, which consists of a broad endless belt of canvas supported upon rollers *k k*. The canvas is held from crimping laterally by means of light wooden battens or slats *l l*, secured to it transversely of its length. The conveyer carries the grain to the duplex elevator D D', which consists of two endless belts whose adjacent faces move in the same direction, so as to grasp the grain between them and raise it by their movement. These belts are, by preference, made of canvas held from crimping by means of light wood battens, and they are supported upon rollers *m m¹ m² m³ m⁴ m⁵*, one of the uppermost, *m*, of which is driven by a belt from a pulley secured to the driving-wheel shaft, so as to impart motion to the elevator-belt. The second belt D' is driven from the first by connecting the uppermost rollers *m m²* of the two by cog-wheels *n n'*. In order that the grain may be more readily grasped between the adjacent surfaces of the elevator-belts, the lower end of the elevator-belt D', which is nearer the conveyer C, is extended over the conveyer, as at D², Fig. 4, and the lower face of this extension is inclined to the conveyer, so as to form an open mouth, into which the grain readily enters, even when lying in a light open condition upon the conveyer. But as the grain is moved onward between the surface of the conveyer and that of the elevator it is compressed between the converging surfaces of the two, and is thus prepared for the action of the duplex elevator, and is caused to enter readily between its surfaces. Another advantage is attained by this extension of the inner elevating-belt, for it may be made wider than the conveyer C, so as to lap beyond the front edge of the latter, as seen at Fig. 6, and thus operate upon such of the butts of the straw as project in advance of the front edge of the conveyer.

In place of constructing the extension D² of the elevator in one piece with the elevator-belt, it may be constructed in the form of a separate belt supported upon rollers and driven at about the same speed as the conveyer beneath it.

In practice, the lower roller *m¹*, which determines the position of the lower end of the outer member D of the duplex elevator, should be set as closely as possible to the conveyer consistently with the leaving of a sufficient space between the two for the battens of the canvas belts to pass.

The use of a duplex elevator whose members are held from crimping by slats or battens, or which is fitted with projections of any kind, is attended with the disadvantage that, after it has raised the grain to its highest limit,

it tends, by the action of the slats, battens, or other projections, to continue to move the grain, and even to carry it downward through the space that must be left between the edge of the receiving-board or binders' table and the surface of the belt of the elevator for the passage of the battens or projections. Moreover, the slats or projections strike the fingers of the binders when they grasp the grain for the purpose of moving it.

In order to obviate these disadvantages, each elevating-belt of the duplex elevator of the machine represented in the drawings is combined with a smooth-surfaced delivery-roller, L and L', which are arranged at the upper end of the duplex elevator, take the grain from it, and deliver it to the position at which the binders require it. As these delivery-rollers have no battens or teeth projecting from their surfaces, they tend to move the grain positively only so long as it is grasped between their opposing surfaces. Hence their diverging upper sides form a smooth-surfaced mouth, in which the elevated grain lies and accumulates by additions from beneath until it is seized by the binder; and, as the surfaces of the rollers are smooth, they do not tend to catch the fingers of the binders, and they also enable receiving-boards or binders' tables to be set close to them, thus closing any opening through which grain might escape. These delivery-rollers are caused to revolve with their surfaces moving in the same direction as those of the duplex elevator; and in the present example they are driven by connecting them with the uppermost rollers *m m²* of the duplex elevator through the intervention of cog-wheels *r r¹ r² r r¹ r²*. The surfaces of the delivery-rollers may be driven at the same speed as those of the duplex elevators; but it is found expedient in practice to drive them at about double the speed of the latter, and the cog-wheels *r r² r r²* are proportioned to that end.

The grain elevated by the duplex elevator accumulates at its upper end, and crowds to the sides thereof, where it is received upon receiving-boards M M'. These are wide enough to hold such grain as may accumulate in the interval between the binding of sheaves; but they are made narrower than is practically sufficient for binding, and binders' tables are provided to support the grain during binding. These binders' tables E E' are arranged crosswise of the length of the receiving-boards, so that the binders face to the rear of the machine when binding the sheaves, and can thus readily push the bound sheaves from them toward the rear of the machine. The binders' tables are, by preference, constructed at the same level as the receiving-boards M M', and as a continuation of their surfaces, so that the grain may be readily moved to the position for binding without lifting it.

The binders' support or foot-board F F' for each binders' table is supported upon the main frame in a convenient position below the level of the receiving-boards and binders' tables,

and, as the receiving-boards are made narrow, (instead of wide enough to bind upon,) the binders' supports at opposite sides of the duplex elevator may be placed closer to each other than would be practicable if the receiving-boards were wide enough to constitute binders' tables. The machine is thus rendered more compact, and the duplex elevator can be placed nearer to the heel of the finger-beam.

The frame-work P of the receiving-boards and binders' tables is made large enough to surround the positions of the binders and form guards therefor; and the inner binders' foot-board F' and the movable standard H of the adjustable reel are arranged relatively near together, so that the binder can readily adjust the position of the reel. That portion of the binders' tables over the cog-wheels n n^1 r r^1 r^2 is formed into a movable flap, Q, so that it may be turned up to afford access to the wheels and journals, and enable the latter to be readily oiled.

Behind the binders' tables a sheaf-carrier, R, is arranged, parallel with them, to receive the bound sheaves and hold them until a sufficient number—say, six—have accumulated to form a shock. The parallel arrangement of the binders' tables, which are fixed in their positions, and this sheaf-carrier facilitates the work of the binders, because, as they face to the rear of the machine and the sheaf-carrier extends across the rear thereof, the bound sheaves can be readily pushed at any moment off the tables into the sheaf-carrier without the necessity of turning the sheaves longitudinally.

A portion, s , of the sheaf-carrier is constructed to tip upon pivots t , so that, when it is tipped downward, the sheaves are permitted to roll or slide off and fall to the ground. This tipping portion or tipping-board s is held in a raised position by means of a cord, u , connecting it with a lever, T, pivoted to the driver's foot-board W, and a catch, x , is provided to hold the lever when the tipping-board s is raised; hence the delivery of the sheaves is under the control of the driver, who, by manipulating the tipping-lever, can free it, and permit the tipping-board to tip and discharge the sheaves, and can then restore the tipping-board to its position for holding the sheaves.

Conveying and elevating apparatus constructed of canvas is liable to have its length affected by wet, the canvas shrinking when wet and extending when drying; hence, if the canvas belts be of the requisite tautness when dry, they are too tight when wet by contact with damp grain, or by other contingencies, and the variations in length affect the working of the apparatus. In order to obviate these difficulties, the elevator aprons or belts D D' are driven in the following manner: At the center of the length of each driving-roller m m^2 a sprocket-wheel, y , is formed, (see more particularly Figs. 7 to 9,) and an endless chain, z , is fitted to these sprocket-wheels, and is extended within the

belt to the farthest roller thereof. This chain, being of metal, is not affected by moisture. The canvas belt or apron of the elevator is made fast at its forward end to this chain, so that the latter in its motion draws along the canvas belt, while the other end of the canvas belt is loosely connected with the forward end by straps w and buckles w' , cords, or other adjustable connections.

The canvas belt is made long enough for the rear end b^1 to overlap the forward end b^2 , so that the contraction or extension of the canvas does not affect the practical extent of the working-surface which operates upon the grain. This method of driving the elevating or conveying belt through the intervention of a driving-chain secures the proper movement of the belt, and permits the belt to expand or contract without straining the rollers, and without affecting the operation of the machine.

Another practical difficulty in the elevating and conveying apparatus of harvesters is, that sometimes straws get in between the heads of the rollers and the frame-work, and are wound upon the gudgeons or journals of the rollers, thus clogging the machine. To obviate this defect, the journal of every roller is provided with a circular straw-guard, m^6 , Fig. 8, whose rim is received in a socket in the roller. This guard is stationary, so that it does not tend to wind up straws, and it protects the journal from contact with them.

The seat S for the driver is secured to the front of the frame of the machine, so that the weight of the driver upon it tends to balance the weight of the sheaf-carrier and the sheaves upon it.

What is claimed as the invention is—

1. The combination, substantially as before set forth, of the collecting-conveyer and the inclined extension of the elevator-belt arranged above the said conveyer.
2. The combination, substantially as before set forth, of the conveyer and the extension of the elevator-belt arranged above the said conveyer, and constructed of greater width than the latter.
3. The combination, substantially as before set forth, of the slotted elevator-aprons and the two smooth-surfaced delivery-rollers, which form a smooth-surfaced mouth at the upper end of said elevator-aprons.
4. The combination, substantially as before set forth, of the two narrow receiving-boards arranged at the opposite sides of the upper end of the elevator, and the binders' tables arranged crosswise of the length of the said receiving-boards.
5. The combination and arrangement, substantially as before set forth, of the fixed binders' tables and a sheaf-carrier, arranged parallel with each other, whereby the bound sheaves can at any moment be pushed directly from the former to the latter without the necessity of turning the sheaves longitudinally.
6. The combination and arrangement of the

binders' support, the reel, the adjustable reel-standard, and the holding device thereof, whereby the binder is enabled to adjust the position of the reel.

7. The combination, substantially as before set forth, of the belt-rollers constructed with sprocket-wheels, the endless driving-chain extended from one belt-roller to the other within the belt, and the belt made fast by its for-

ward end only to the said driving-chain, and free to extend or contract relatively to said chain.

Witness my hand this 29th day of December, A. D. 1876.

GEORGE HENRY SPAULDING.

Witnesses:

CALVIN FORD,

W. F. HENDLER.