

L. VAN DOREN.
Rotary Engine.

No. 201,574.

Patented March 19, 1878.

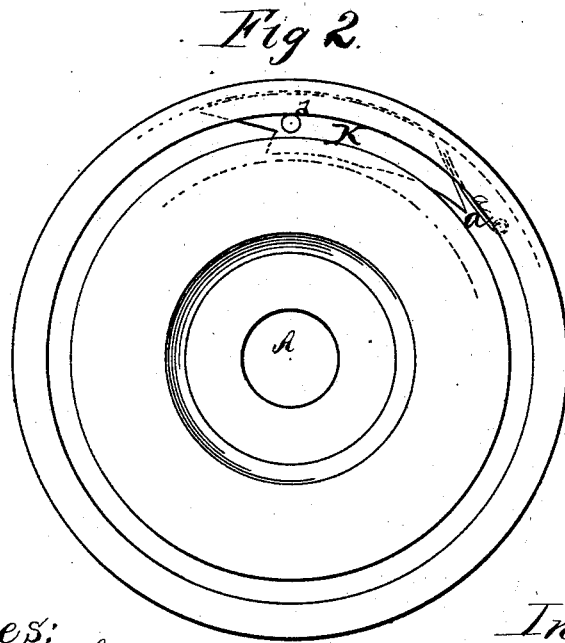
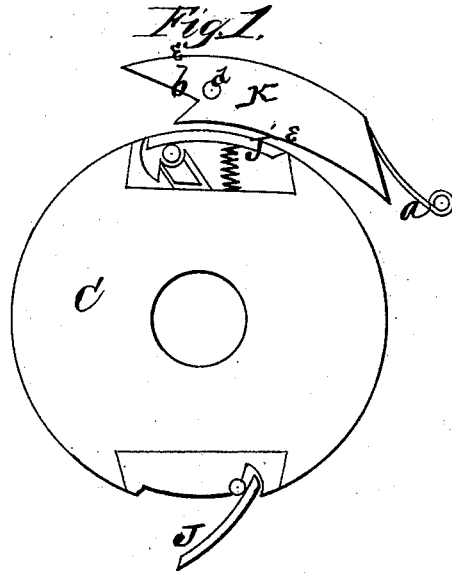

Witnesses:
H. C. McArthur,
C. H. Eunk

Inventor:

Lansing Van Doren

L. VAN DOREN.
Rotary Engine.

No. 201,574.

Patented March 19, 1878.

Fig. 3.

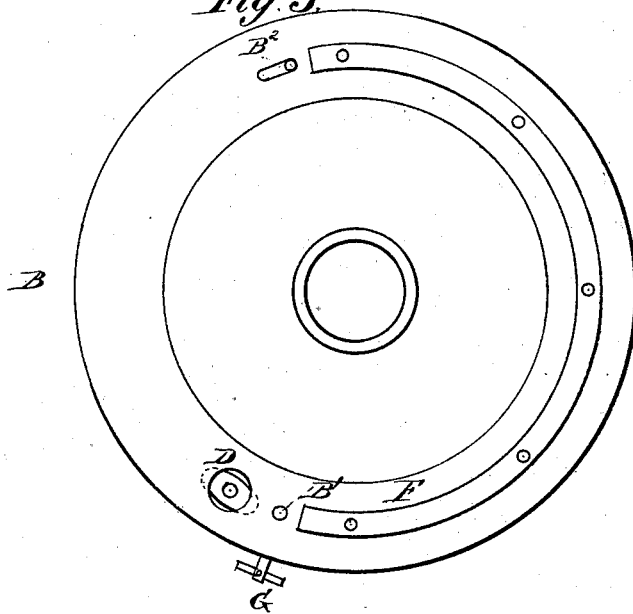
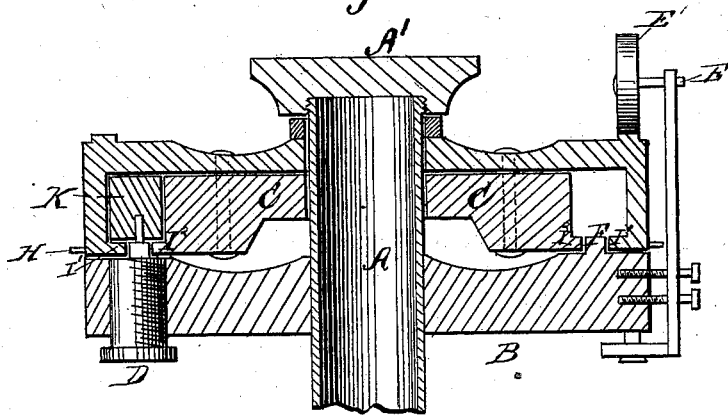

Fig. 4.



Witnesses:
H. C. Arthur,
C. R. Ewert

Inventor:
Lansing Van Doren

UNITED STATES PATENT OFFICE.

LANSING VAN DOREN, OF WASHINGTON, DISTRICT OF COLUMBIA, (WILLIAM T. VAN DOREN, JR., ADMINISTRATOR.)

IMPROVEMENT IN ROTARY ENGINES.

Specification forming part of Letters Patent No. 201,574, dated March 19, 1878; application filed April 24, 1877.

To all whom it may concern:

Be it known that I, LANSING VAN DOREN, of Washington, in the county of Washington and District of Columbia, have invented certain new and useful Improvements in Rotary Motor; and I do hereby declare that the following is a full, clear, and exact description thereof, which will enable others skilled in the art to which it appertains to make and use the same, reference being had to the accompanying drawings, and to letters of reference marked thereon, which form a part of this specification.

The nature of my invention consists in the construction and arrangement of a rotary motor, as will be hereinafter more fully set forth.

In the annexed drawings, to which reference is made, and which illustrates my invention, Figure 1 shows an inside view of a portion of the rotating disk, with the pistons and the pivoted abutment to one side thereof. Fig. 2 is a similar view of the entire rotating disk. Fig. 3 is a plan view of the stationary disk; and Fig. 4 is a central section of the entire motor.

Corresponding letters denote like parts in all of the figures.

This invention relates to rotary motors; and it consists in first providing such motors with partially-balanced pivoted pistons; and, secondly, in providing them with a pivoted abutment for the steam to act against; and, lastly, in the combination and arrangement of certain of the parts of which it is composed, as will be more fully described hereinafter.

In constructing engines of this character I use a shaft or standard, A, which may be of any required diameter and form that will enable it to support the disks, soon to be described, either in a vertical or in a horizontal position. The outer end of this shaft or standard is provided with a nut or cap, A', as shown in Fig. 4, for the purpose of holding the disks in contact. Upon the shaft or standard A there is placed a disk, B, which is firmly secured thereto. This disk is provided with an induction-port, B¹, and with an eduction-port, B², Fig. 3, the relative locations of which may be such as to cause the steam, after it has been admitted into the annular chamber or

channel in the revolving disk C, in which the pistons and the abutment are placed, to follow the piston throughout any portion up to nearly the whole of its revolution. Just in the rear of the induction-port there is placed a support, D, which is adjustable, as shown in Fig. 4, the object being to cause its inner end to form the pivotal point upon which the abutment rests, its upper end, just below the pivotal point being, by preference, made of the oval form shown in Fig. 3 at D, so that the abutment may rest thereon and have as much bearing-surface as possible. Upon one side of the stationary disk B, and at some point between the induction and the eduction point, there is placed a bracket, E, which extends upward far enough to allow its upper end to carry a wheel, E', which overhangs and rests upon the upper surface of the revolving disk, in order that the steam between the two disks may not press them apart, so as to cause a leakage of steam. Just in front of the induction-port there is placed a segmental plate, F, as shown in Fig. 3, the object being to cause a steam-tight joint between the pistons and said plate when the steam is being used, and so that the friction of the pistons may be relieved during the other portion of the revolution.

If it is found desirable to provide a cut-off valve for an engine of this character, such a valve may be placed within the induction-port and operated by pins in, or projections upon, the revolving disk, one form of valve for such a purpose being shown at G, Fig. 3, and the pins or projections at H H, Fig. 4.

On one side of the stationary disk B there is placed a disk, C, which is made to rotate upon the shaft or standard A, its under surface being turned to form flanges I I', which form an annular chamber or channel, I², in the revolving disk. Into the annular space between the annular flanges I and I' the support D for the pivoted abutment enters, and also the segmental plate F, which is secured to the stationary disk B. In the outer edge of the inner portion of the revolving disk, at opposite points or at such intervals as may be required, there are placed swinging pistons J J, which are pivoted at points at some distance from

one of their ends, as shown clearly in Fig. 1, the object being to partially balance said piston, in order that, in being forced open by the entrance of the steam into the groove in which they move, they shall not be made to move so rapidly as to destroy themselves or to cause any thump or jar in the machine. The bearing-points of these pistons may be made of any kind of non-corrosive metal, or of any kind of metal which will stand the greatest amount of wear—such, for instance, as bronze, or what is known as "Babbitt metal."

As before remarked, any number of these pistons may be used, according to the size of the machine or the views of the constructor.

K represents an abutment, constructed substantially as shown in Fig. 1. This abutment is pivoted to the support D, and is thus prevented from moving with the disk C, its short end, against which the steam-pressure is exerted, is curved or beveled, as shown at *b* in Figs. 1 and 2, in order that the steam, by pressing against the outer surface of the end presented to its action, may tend to keep the curved surfaces E E thereof in contact with the walls of the chamber or channel in which it is placed, and that without causing any undue friction.

Should it become necessary to use additional means to press the curved surfaces of this abutment into contact with the walls of its channel or chamber, a spring, *a*, may be applied to its outer end for that purpose, as shown in Figs. 1 and 2, the end of the spring *a* bearing against the inner surface of the outer disk.

It will be seen that, owing to the construction of this abutment, it can accommodate itself to any slight imperfections in the walls of the groove in which it is placed, and in the event of any wear in the disk it will accommodate itself thereto, and thus at all times form perfect steam-joints.

My motor, though principally intended to be operated by steam, can, of course, also be operated by water, compressed air, or gases, as may be deemed most advantageous.

My principal object to which to apply my invention is for locomotion, by locating the motor upon an axle of suitable construction, and letting the outer disk C form the wheel proper. In such case the said disk must be properly constructed for the purposes to which it is intended, whether for ordinary road-wagons, street-cars, or railroad-cars. In like manner it may also be applied to propellers, by forming cogs on the disk C to mesh with gear on the propeller-shaft.

For locomotion, the disk C may also form only a driving-wheel, by connecting the same by cogs or belts with the axle. In like manner it may also be used for stationary purposes to drive machinery of any kind.

Having thus described my invention, what I claim, and desire to secure by Letters Patent, is—

1. The abutment K, pivoted near the front end, said end being beveled, as shown, and both the outer and inner surfaces curved to form automatically steam-tight joints with the surface of the disk against which it bears, substantially as herein set forth.

2. The disk C, provided with the underhanging annular flanges I I', to form the annular chamber or channel I², for the purposes herein set forth.

3. The combination of the segmental plate F and the disks B and C, substantially as and for the purposes herein set forth.

4. The combination of the stationary disk B, revolving disk C, segmental plate F, pistons J, abutments K, cut-off valve G, and pins or projections H H, all constructed substantially as and for the purposes herein set forth.

In testimony that I claim the foregoing as my own I affix my signature in presence of two witnesses.

LANSING VAN DOREN.

Witnesses:

FRANK GALT,
C. M. CONNELL.