

J. S. COVERT, M. D. GARNER & L. B. WALTHALL.  
 Bag Holder.

No. 201,653.

Patented March 26, 1878.

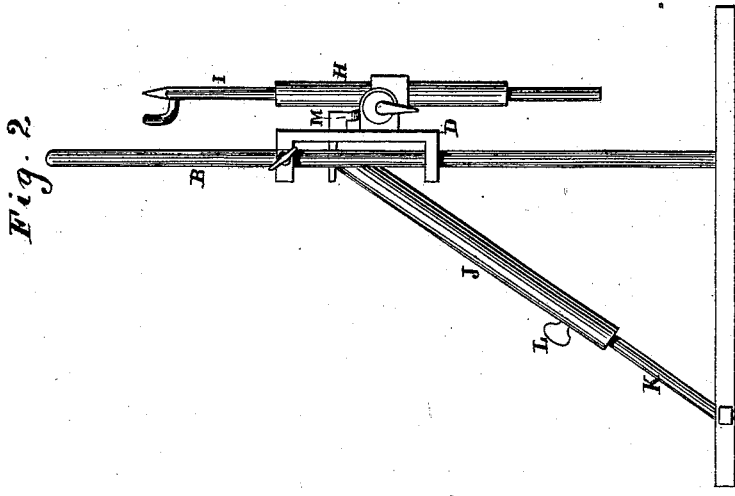

Fig. 2.

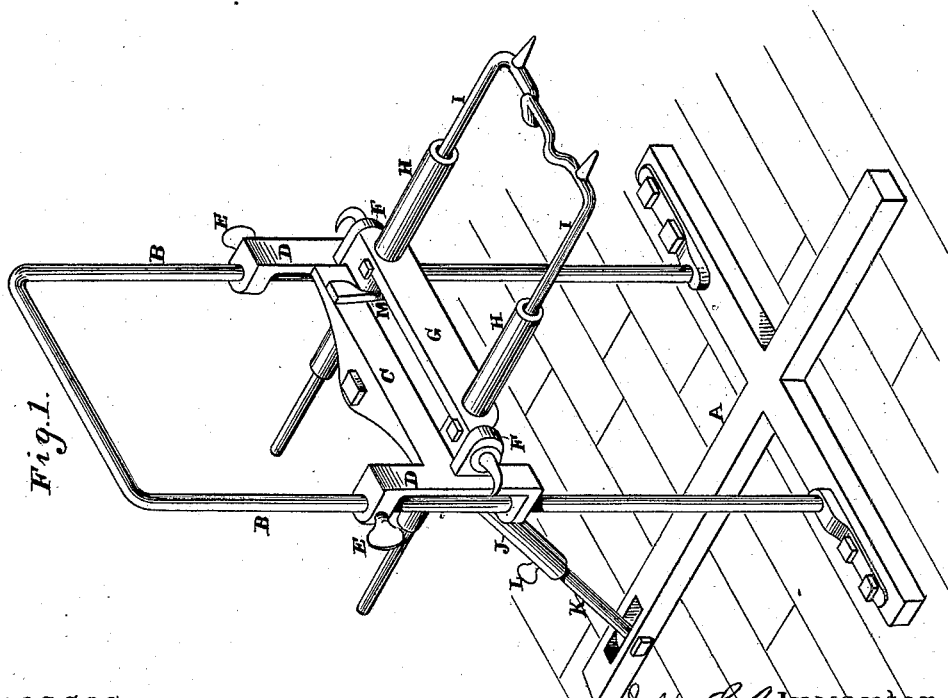

Fig. 1.

Witnesses  
 Dr. L. Boone  
 Geo. H. Strong.

Inventor  
 John S. Covert  
 M. D. Garner  
 Lawson B. Walthall  
 by Sewell & Co.  
 attys

# UNITED STATES PATENT OFFICE.

JOHN S. COVERT, MONROE D. GARNER, AND LAWSON B. WALTHALL, OF  
MODESTO, CALIFORNIA.

## IMPROVEMENT IN BAG-HOLDERS.

Specification forming part of Letters Patent No. **201,653**, dated March 26, 1878; application filed  
January 14, 1878.

*To all whom it may concern:*

Be it known that we, JOHN S. COVERT, MONROE D. GARNER, and LAWSON B. WALTHALL, of Modesto, county of Stanislaus, and State of California, have invented a Device for Holding Sacks while being filled; and we do hereby declare the following to be a full, clear, and exact description thereof, reference being had to the accompanying drawings.

Our invention relates to certain improvements in a device for holding sacks while being filled for which a patent was issued to John S. Covert, August 28, 1877.

Our improvements consist, first, in mounting the frame and sockets upon a portable vertical standard in such a manner that the holder may be elevated or depressed to suit any height or size of sack.

Our invention further consists in extending the tubes or sockets which receive the sliding bars through the axis or bar upon which they turn, so that the slides may be made as long as desired; and, lastly, in the employment of a spring-catch, by which the holding-bars are held up out of the way when desired.

In the accompanying drawings, Figure 1 is a perspective view of our device. Fig. 2 is a side elevation.

A is a base or cross, so made as to stand firmly wherever it may be placed, and B is a standard consisting of two vertical posts, which are firmly secured to the base, and may be united at the top, as shown, for greater strength. Upon these posts is fitted a frame, C, having sliding guides D, and by means of set-screws E this frame may be secured at any height upon the posts B, so as to bring it to the proper height for any size of sack which it may be necessary or desirable to use.

Journal-boxes F upon the frame C support the axis G, which receives the tubes H, and this axis is made flat, and perforated so that the tubes extend through the axis.

By this construction we are enabled to extend the rods I back of the frame and make them of any desired length, or push them back to accommodate small sacks. A tube, J, and rod K, forming a telescopic brace, extend from the frame C down to one of the arms of the base A, and are pivoted there, so that by loosening the set-screw L the brace may be lengthened or shortened, to accommodate the raising or lowering of the frame C, after which the screw may be fixed, and the device will stand solid.

Instead of a catch to hold the sack-holder up when desired, we have attached a spring, M, to the frame C, and this spring projects downward, so as to press against the socket or tube H. When the device is turned up this spring will hold it in position by its pressure, and the device may be turned down without trouble of loosening a fixed catch.

Having thus described our invention, what we claim, and desire to secure by Letters Patent, is—

1. The axis G, having the tubes H, passing through the same, in combination with the sliding rods I, substantially as and for the purpose described.

2. The frame C and spring M attached thereto, in combination with the journaled bar G and holding device H I, as set forth.

3. The slotted base A, frame C, and bag-holding device G H I, in combination with the swinging telescopic support K J and set-screw L, substantially as described.

In witness whereof we have hereunto set our hands and seals.

JOHN S. COVERT. [L. S.]  
M. D. GARNER. [L. S.]  
L. B. WALTHALL. [L. S.]

Witnesses:

S. M. MITCHELL,  
W. B. RICE.