

J. E. WAKEFIELD.  
Folding Table.

No. 201,723.

Patented March 26, 1878.

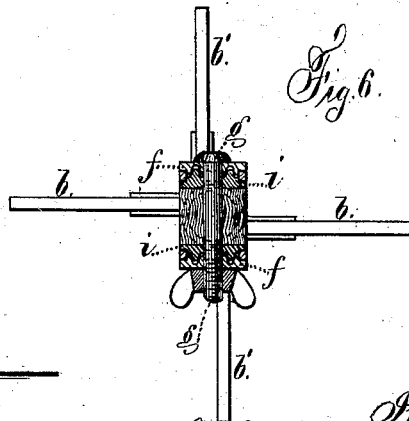
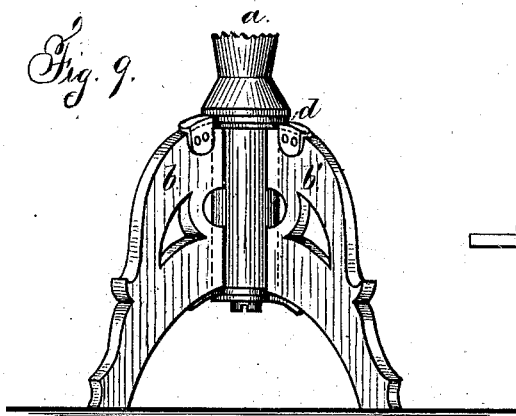
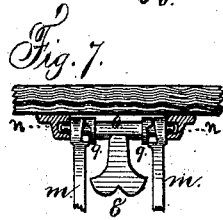
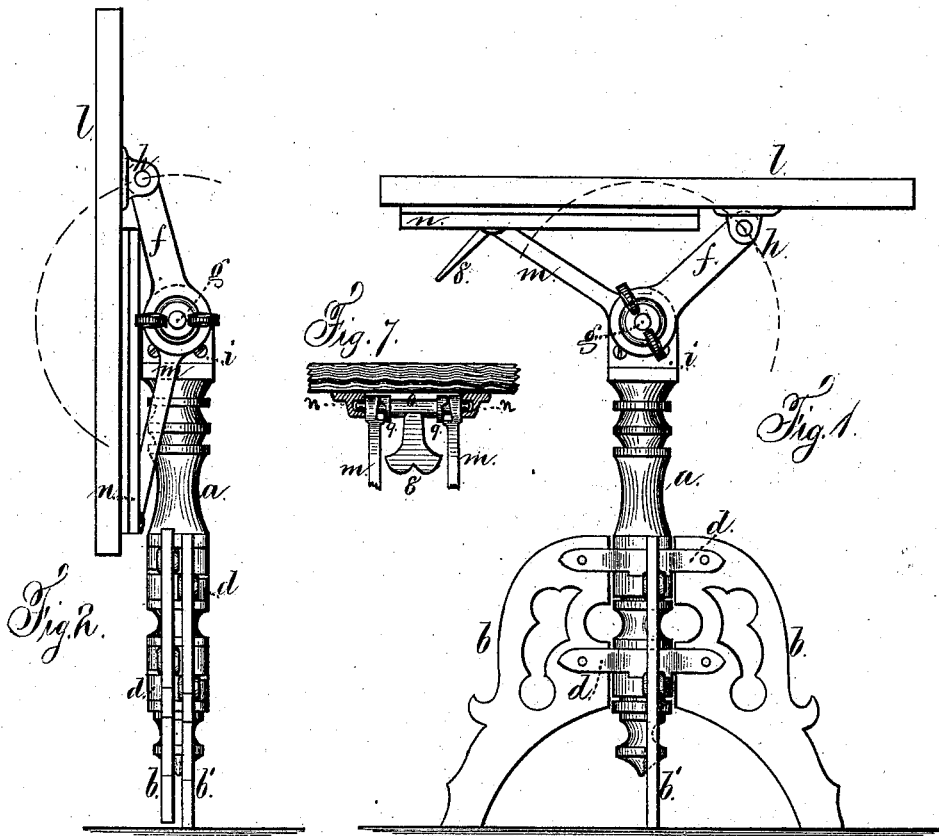

Witnesses  
 Char. H. Smith  
 Geo. T. Pinckney

Inventor  
 John E. Wakefield.  
 per Lemuel W. Perrell  
 atty

J. E. WAKEFIELD.  
Folding Table.

No. 201,723.

Patented March 26, 1878.

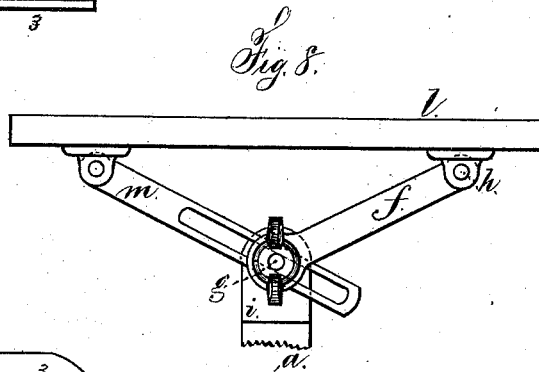
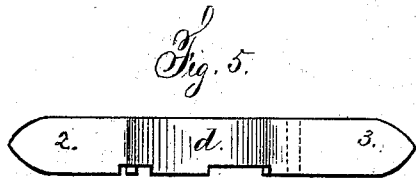
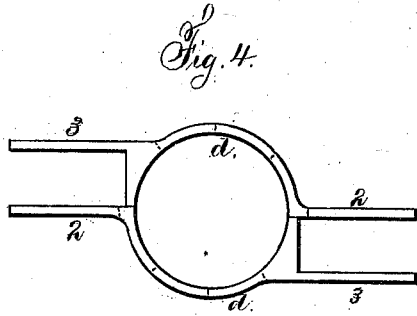
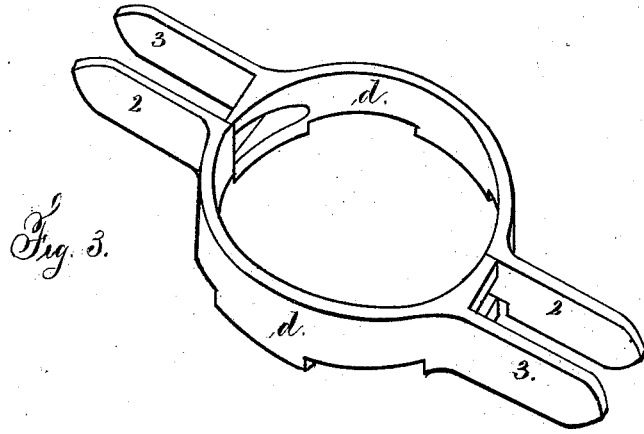

Witnesses

Chas. H. Smith  
Geo. T. Pinckney

Inventor

John E. Wakefield  
per Lemuel W. Correll  
att'y

# UNITED STATES PATENT OFFICE.

JOHN E. WAKEFIELD, OF WORCESTER, MASSACHUSETTS.

## IMPROVEMENT IN FOLDING TABLES.

Specification forming part of Letters Patent No. **201,723**, dated March 26, 1878; application filed February 21, 1878.

*To all whom it may concern:*

Be it known that I, JOHN E. WAKEFIELD, of Worcester, in the State of Massachusetts, have invented an Improvement in Folding Tables and Legs, of which the following is a specification:

Folding tables have been made with a central standard that can be revolved, and there has been a clamp to hold the standard to the top and allow the latter to be moved to an inclination to the standard, or to be swung into line with the same, and in some instances the legs have been made to fold flat, so as to allow of being packed into a small compass.

My improvement is made for the purpose of simplifying the construction and rendering the table very strong and durable; at the same time allowing the table and legs to be packed, when not in use, into a very small space.

The folding legs are of peculiar construction, and especially adapted to folding tables; but the same might be applied to pivot or revolving chairs. There is a central standard, to which the legs are connected by peculiar locking-rings, and the legs are united in pairs, to allow of their being folded together flat, or opened at right angles to each other, or nearly so, and the top of the standard is provided with a clamping-screw and connecting-links to the table-top. These parts are constructed so that the links allow the table to be raised or lowered, or placed at a greater or less inclination, or folded down against the standard for lessening the space occupied by the table when not in use, or when packed for transportation.

In the drawing, Figure 1 is an elevation of the table. Fig. 2 represents the parts as packed together for transportation. Fig. 3 shows the locking-rings in perspective, without the legs or standard. Fig. 4 is a plan view of the locking-rings; Fig. 5, an elevation of one of the locking-ring segments; and Fig. 6 is a sectional plan at the joint of the standard. Fig. 7 is a cross-section of the slides upon the table. Fig. 8 represents a modification in the link from the table to the joint; and Fig. 9 is a side view of the rings for the legs, in a modified form, as applied to the table.

The standard *a* is more or less ornamental, and the legs *b b'* are cut out, carved, or otherwise made in any desired configuration. They are connected together in pairs at opposite sides of the standard; but, in order to allow the legs to be turned around the standard until they lie flat against each other, as illustrated in Fig. 2, the radial line from the central column does not pass through the center of each leg, but at the side of the same, so that the respective pairs of legs can be swung toward each other until nearly in contact, and they will be parallel, or nearly so, to each other, and a vertical radial plane will pass between and parallel to the legs of the respective pairs of legs.

In order to unite the opposite legs in pairs, I make use of flanged segmental rings *d*, surrounding the column *a*, and attached at their outer ends to the legs. Each half-ring is made with two flanges, 2 and 3. The flange 3 is a tangent to the ring, and the flange 2 is in the line of a prolongation of the radius to the circle. Hence, when two of these segments are placed in reverse position, as indicated in Fig. 3, a complete circle or ring is made to surround the cylindrical portion of the standard *a*, and form a jaw at each side to receive the edges of the legs.

There are, by preference, two pairs of these segmental rings to each pair of legs, and these come near each other upon the column *a*, as shown in Fig. 1. It will now be apparent that the pairs of legs are very firmly connected by these segmental rings when the edges of said legs are entered into the jaws between the flanges of the segments and secured by rivets or screws passing through the same.

The legs, formed and connected as aforesaid, can be placed at right angles to each other for supporting the table, or the legs can be folded, as aforesaid. It is desirable to lock these rings in their proper relative positions when the legs are open, so as to retain them. For this purpose recesses are made in the adjacent edges to receive the projections between the corresponding recesses of the adjacent ring-sections. It is preferable to locate these notches and projections so that they will not interlock

when folded, but that they will interlock when the legs are opened, and by proportioning the parts, as represented, all of the ring-segments (including the notches and projections) may correspond in all particulars, so that one pattern only is required in casting them.

It is preferable to support the standard and table by the shoulders or ribs of the standard coming above the rings; and it will be apparent that the pair of legs *b'* that is connected by the lower pair of ring-segments will require to be drawn down sufficiently from the other ring-segments to separate the notches and projections before the legs can be folded; hence, when in use, the weight of the table keeps these notches and projections interlocked.

The standard usually is free to be revolved in the rings; but a clamping or set screw may be provided to hold the same from turning.

At the top of the standard there are links *ff*, attached by the cross-bolt *g* to such standard, and the other ends of the said links are hinged at *h* to the under side of the table. The faces of the links *f* around the bolt *g* are made with circular grooves, receiving the circular ribs upon the plates *i* that are attached to the side faces of the standard, so that the connection is made rigid by tightening up the screw-bolt *g*. It will be seen that, according to the position or angle of these links *f*, the joint *h* will be at a greater or less elevation from the floor, and that the table-top *l* can be turned upon the joint *h* into any desired position, either horizontal, vertical, or at an inclination.

I make use of a second link or pair of links, *m*, passing off from the joint *g* in the opposite direction to the links *f* to the table-top, so as to form with said links *f* a triangle, that supports the table-top. This triangle will be flat when the table-top is near the top of the standard *a*, and will be more acute when the table-top is raised.

There are several ways in which the links *m* can be connected at their ends to the under side of the table and the standard respectively. I have shown in Figs. 1 and 2 the links *m* as provided with ring-eyes at the ends adjacent to the top of the standard, such rings passing around circular ribs upon the plates *i*, and lying between the links *f* and the plates *i*, and the outer ends of these links *m* are between slides *n*, fixed firmly to the under side of the table *l*.

There are grooves in the opposite faces of these slides *n*, in which the ends of a cross-bolt slide, (see sectional view, Fig. 7,) such bolt passing through the ends of the links *m*, and also through a cam-lock, *o*, that has a lever, *8*, by which it is turned, and cam-shaped ends *9* that act against similar cam-faces at the sides of the links *m*, so that when the lever *8* is moved the ends of the links *m* will be forcibly pressed against the faces of the slides *n*, to retain the parts in whatever position they may be placed.

The reverse movement liberates the parts and allows the inclination to be varied, and it will be apparent that by loosening the bolt *g* the table can be raised or lowered, and then by loosening the cam-lock *o* the table can be placed level or at an inclination, as desired. The bars *n*, forming the slide, may be simply screwed to the table, or connected by cross-bars to resist the thrust of the cams. Screws may take the place of the cams.

It will be evident that, in place of using a slide, *n*, the end of the links *m* next the table-top may be provided with a joint, as seen in Fig. 8, and a slot be made in the link or links for the bolt *g*, to allow of the adjustment aforesaid. In this case the parts will be held by the clamping action of the bolt *g*, or a nut especially provided for such links *m*.

If desired, both links or sets of links *f m* may be slotted, and a compound bolt, *g*, provided with a thumb-nut at each end, one acting to clamp the link or links *f*; the other the link or links *m*.

When the table is to be folded into a small space, the parts are swung into the position shown in Fig. 2. If the links *f* are provided with clamping devices at each end of sufficient strength, then the links *m* may be dispensed with.

If desired, each ring *d* may be made in one piece, and with one or two flanges for each leg. In this case the standard of the table will be slipped endwise through these rings, and in this case the bottom rings may be displaced by round plates, with wings or flanges for the legs, and a central screw through such plates entering the end of the standard, to connect and apply friction to the parts to hold the legs in position, as seen in Fig. 9; or catches or locks may be used, as aforesaid.

I claim as my invention—

1. The combination, with the standard *a*, of the pairs of folding legs *b b'* and the rings *d*, for uniting such legs in pairs and connecting them to the standard *a*, substantially as set forth.

2. The segmental rings *d*, provided with the flanges 2 and 3, in combination with the legs *b b'* that are received between such flanges, and united in pairs, substantially as set forth.

3. The combination, with the table-top *l* and standard *a*, of the links *f*, connected at one end by joints to the table-top and at the other end to the top of the standard, substantially as set forth.

4. The plates *i*, having interlocking circular flanges, in combination with the standard *a*, table-top *l*, links *f*, and clamping-bolt *g*, substantially as set forth.

5. The combination, with the standard *a* and table-top *l*, of the links *f* and *m*, connected at their respective ends to such standard and table, and allowing the table to be raised, lowered, or tipped, substantially as set forth.

6. The slides *n*, cross-bolt *g*, cam-lock *o*, and links *m*, in combination with the standard *a*,

table-top *l*, and links *f*, substantially as set forth.

7. The combination, in a folding table, of a standard, folding legs connected in pairs at opposite sides of the standard, a table-top, and links connecting the standard and table-top, substantially as set forth, whereby the parts can be folded, substantially as set forth.

Signed by me this 15th day of February,  
A. D. 1878.

JOHN E. WAKEFIELD.

Witnesses:

HENRY BACON,  
F. J. BARNARD.