

H. H. POTTER.  
 Railway Switch.

No. 201,826.

Patented March 26, 1878.

Fig. 1.

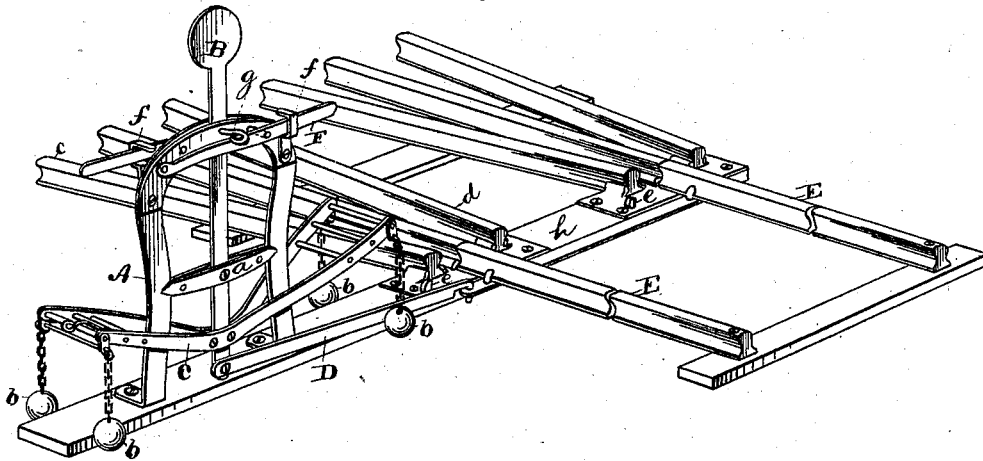

Fig. 2.

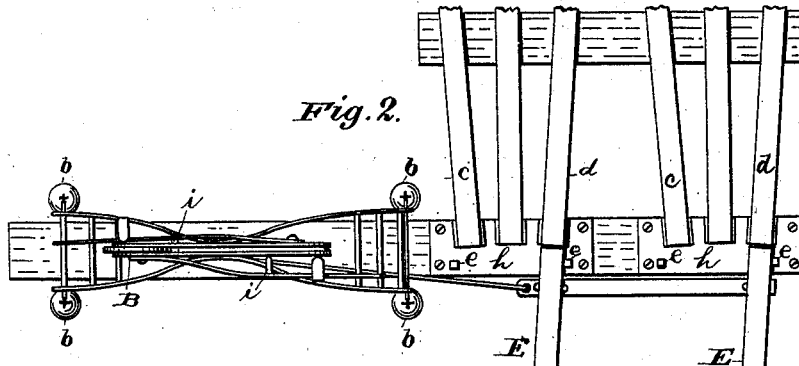
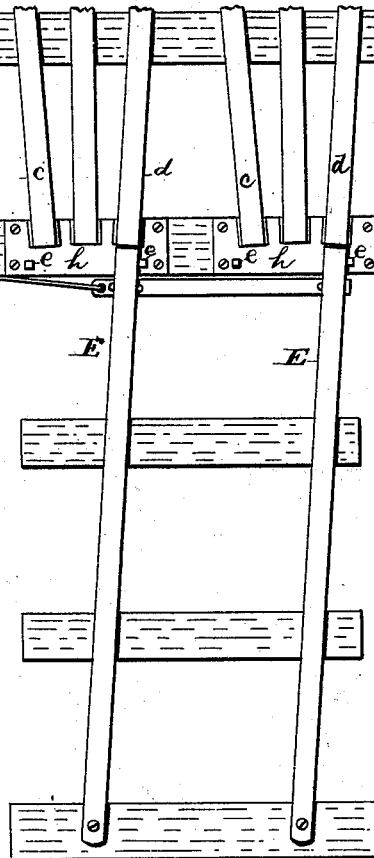
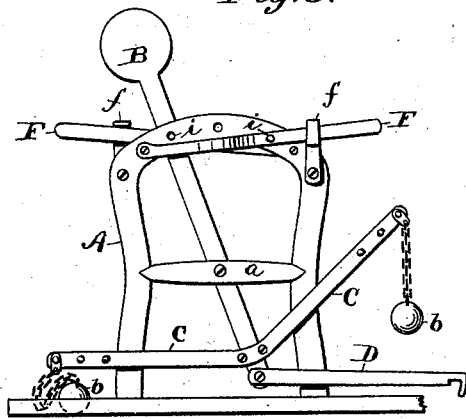

Fig. 3.



Witnesses:  
 W. A. Brown  
 Albin M. Long.

Inventor:  
 H. H. Potter  
 Per H. S. Abbot  
 Attorney.

# UNITED STATES PATENT OFFICE.

HENRY H. POTTER, OF STERLINGVILLE, NEW YORK, ASSIGNOR OF ONE-HALF HIS RIGHT TO H. H. DOOLITTLE, OF PHILADELPHIA, PENNSYLVANIA.

## IMPROVEMENT IN RAILWAY-SWITCHES.

Specification forming part of Letters Patent No. 201,826, dated March 26, 1878; application filed March 15, 1878.

*To all whom it may concern:*

Be it known that I, HENRY H. POTTER, of Sterlingville, in the county of Jefferson and State of New York, have invented certain new and useful Improvements in Railroad-Switches; and I do hereby declare that the following is a full, clear, and exact description thereof, which will enable others skilled in the art to which it appertains to make and use the same, reference being had to the accompanying drawings, and to letters of reference marked thereon, which form a part of this specification.

Figure 1 is a perspective view, showing the switch-rail set for the main track. Fig. 2 is a plan view, showing the switch-rail set for one of the side tracks. Fig. 3 is a side view of the operating device as it appears in setting the rails, as indicated in Fig. 2.

The main object of my invention is to construct a switching device by which, as soon as the lever is released, the switch-rail will assume its connection with the main track; and to the accomplishment of this object my invention consists of a rocking frame weighted at both ends, connected by a bar to the rails, and operated by a pivoted lever.

In the accompanying drawing, the letter A represents a standard with a cross-bar, *a*, to which is pivoted a lever, B. This lever has joined to it, at or near its lower end, a rocking frame, *c*, weighted at both ends with chains and balls *b*, which just touch the ground when the switch is set for the main track.

While this frame is represented as weighted by four balls, yet it is obvious that a less number than four will answer the purpose. For instance, there may be but two weights, one suspended from either end.

A bar, D, connects the lever B with the switch-rails E, which are rendered capable of a to-and-fro motion in the usual way. The letters *c* and *d* indicate branch rails, and the other rails shown are those of the main track. The upper part of the lever B has an eye through it, which corresponds with either of the three eyes in the top of the standard A, to either side of which is fastened a spring-bar, F, held by hooks *f*, and provided with pins *i*, which, when the spring-bar is moved toward the

standard A, pass through the eyes in the standard and lever and hold the latter in position till released.

The operation of the device is as follows: When the switch-rails connect with the main track the lever has the upright position indicated in Fig. 1, and is held firmly in that position by the pin *g*. When it is so held the rocking frame is in equilibrium, the two ends being in about the same plane, and the weights just touching the ground.

When it is desired to switch a train from the main to the branch track, the pin *g* is withdrawn, the switchman grasps the lever B, places his foot on the end of the rocking frame, and slightly bears the weight of his body thereon, which movements draw the lever toward him, depress the end of the frame on which his foot rests, and throw the switch-rails in connection with the branch track, beyond which they are prevented from passing by pins or knobs *e* on the plate *h*. At the time the lever and frame are borne down and the switch-rails are thrown into position the leg or body of the switchman is pressed against the spring-bar F, and the pin *i* is thus pushed through the eye in the standard and lever, thereby holding the latter, and through it the switch-rails, firmly in place. After the train has passed, the switchman relieves the rocking frame of his weight, the spring of the bar F throws the same against the hook *f*, which frees the pin *i* and releases the lever B, which is drawn into an upright position by the weights pulling down the elevated end of the rocking frame until they again touch the ground, thus restoring the equilibrium of the same and throwing the switch-rails again into connection with the main track, in which position they are held by the pin *g* passing through eyes in the standard and lever.

I do not confine myself to any particular method of weighting the end of the rocking frame, because any means of doing the same whereby the weight of one end will restore equilibrium to the frame when the same has been disturbed will serve the purposes of my invention.

Having described my invention, what I claim is—

1. The combination of the lever B and weighted frame C, substantially as and for the purposes set forth.

2. The lever B and weighted frame C, in combination with the frame A, and spring-bar F, and connecting-bar D, and switch-rail, substantially as described.

In testimony that I claim the foregoing as my own I affix my signature in presence of two witnesses.

HENRY H. POTTER.

Witnesses:

H. B. BROWN,  
ALBIN M. LONG.