

J. H. ALKER.

Machine for Rolling Sucker-Rod Blanks.

No. 201,861.

Patented April 2, 1878.

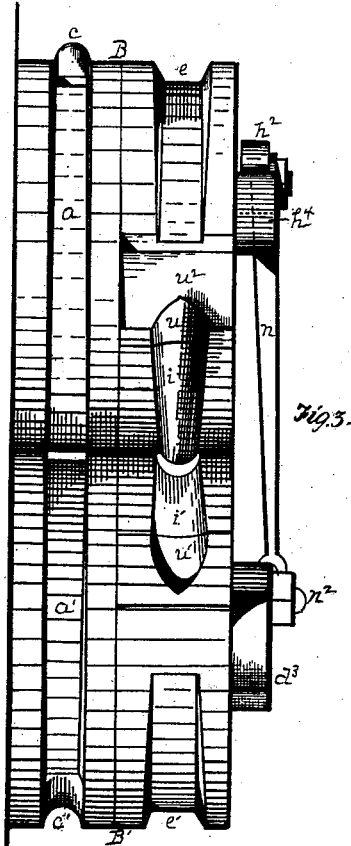
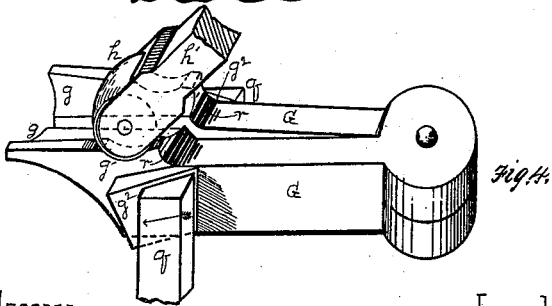
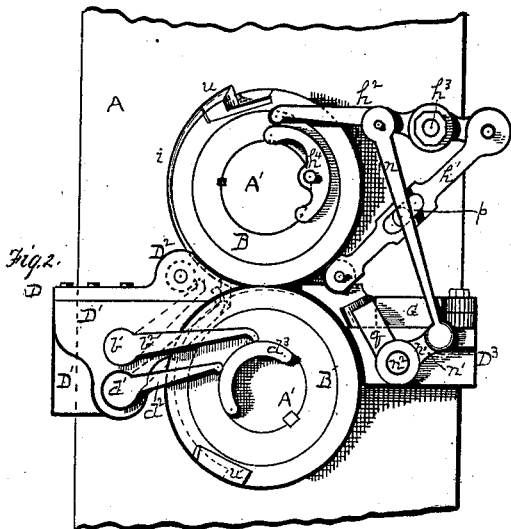
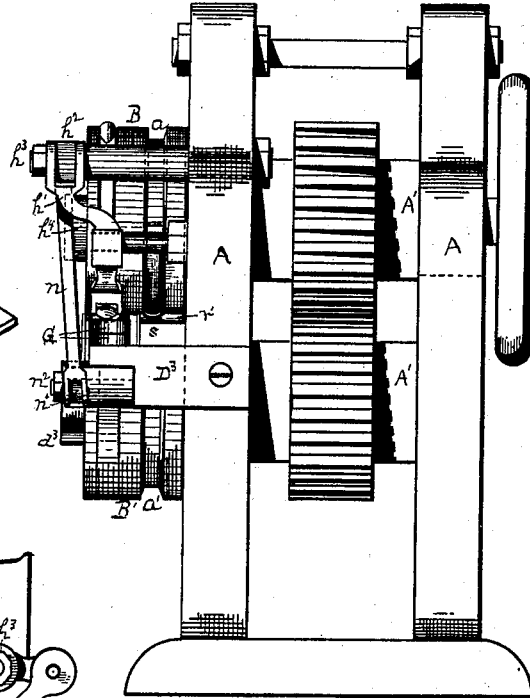
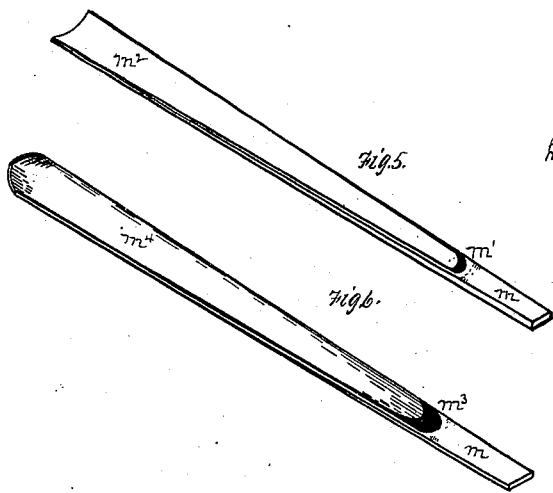

ADDRESSES.
 George H. Christy
 Claudius Parker

INVENTOR
 John H. Alker

J. H. ALKER.

Machine for Rolling Sucker-Rod Blanks.

No. 201,861.

Patented April 2, 1878.

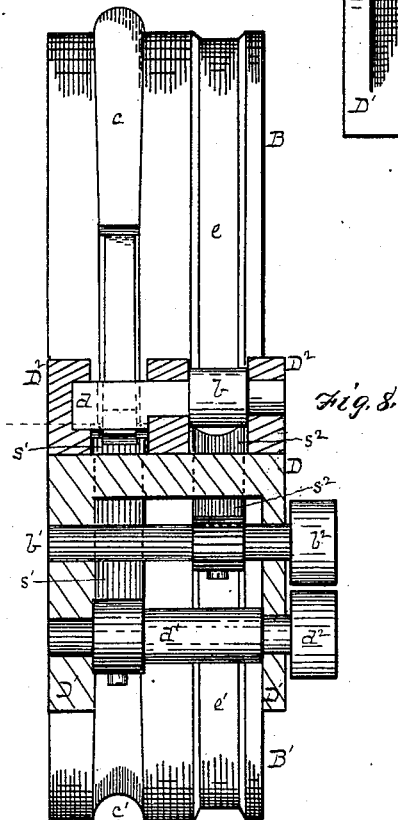
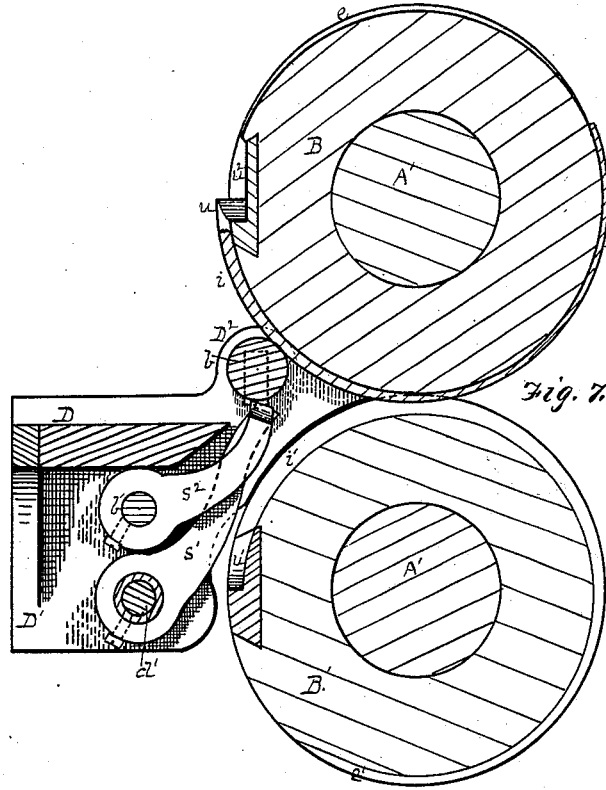

WITNESSES.

George A. Christy
 Claudius L. Parker

INVENTOR.

John H. Alker

UNITED STATES PATENT OFFICE.

JOHN H. ALKER, OF PITTSBURG, PENNSYLVANIA, ASSIGNOR TO JONES & LAUGHLINS, OF SAME PLACE.

IMPROVEMENT IN MACHINES FOR ROLLING SUCKER-ROD BLANKS.

Specification forming part of Letters Patent No. **201,861**, dated April 2, 1878; application filed November 30, 1877.

To all whom it may concern:

Be it known that I, JOHN H. ALKER, of Pittsburg, county of Allegheny, State of Pennsylvania, have invented or discovered a new and useful Improvement in Machines for Forging Sucker-Rod Blanks; and I do hereby declare the following to be a full, clear, concise, and exact description thereof, reference being had to the accompanying drawings, making a part of this specification, in which—like letters indicating like parts—

Figure 1, Sheet 1, is a front elevation of my improved machine. Fig. 2 is an end elevation of the operative mechanism thereof. Fig. 3 is a rear elevation, to an enlarged scale, of the rolls and dies. Fig. 4 is a detached view, in perspective, also to an enlarged scale, of a portion of the operative mechanism, as presently to be explained. Fig. 5 shows, in perspective, the blank as produced by the machine at the first pass. Fig. 6 shows the product of the second pass. Fig. 7, Sheet 2, is a vertical transverse section through the rolls in the central plane of the finishing-dies, and showing the rear guides and scrapers; and Fig. 8 is a rear elevation of the rolls and a sectional elevation of the rear guides.

My improved machine is particularly designed for the production of blanks for the coupling of sucker and piston rods used in oil, salt, and other deep wells, by forging and shaping the same between revolving or oscillatory rolling-dies.

These blanks, as now required in the art, have to be made of concavo-convex form, and of an increasing width and a gradually-decreasing thickness toward the extreme outer end, substantially as indicated in Fig. 6; but these characteristic features may be varied more or less, or, aside from the concavo-convex form, may be entirely omitted.

In my machine these features, however, are secured by two passes of the blank, or by two forging operations, though this number may be increased at pleasure, or the devices employed at each pass may be incorporated into the structure of different machines; but for convenience of illustration, and also because I believe it to be the best, I have shown the entire invention in one machine.

The housings or frame-work A may be of any suitable construction for carrying the roll axles or shafts A', the latter being driven by any known suitable machinery, as shown, or otherwise. A pair of forging-rolls are represented at BB', outside the housings or frame. These rolls have a double arrangement of forging-dies, such in their general features as are already known in the art for kindred uses. The first or inner pair of such forging-dies have, first, a groove or grooves, *a a'*, of sufficient size for the rectangular bar (the general shape of which, in cross-section, is shown at *m*, Figs. 5 and 6) from which the blank is to be made to be passed through, preparatory to the bite thereon of the convex-faced tongue or die *c* and the concave-faced groove or counter-die *c'*. These dies are so shaped and proportioned that, after the bar is properly inserted, they will engage it at or about the point *m'*, Fig. 5, and, rolling it back, will bring it to the usual or desired concavo-convex shape, and with or without, but preferably with, the taper form shown in Fig. 5. In order to insure this result, and prevent the bar from turning sidewise while thus being forged between the rolling-dies *c c'*, I employ the guides shown in Figs. 1, 2, 7, and 8. A front guide-table, having a slight concavity in line with the bottom of the delivery, is shown at *s*, Fig. 1. A rear guide-table is shown D, and the latter is supported by any suitable brackets, D'. The table D is properly boxed in the line of feed for the passage of the bar.

In the raised ears D², I arrange a transverse scraper, *d*, Fig. 8, in such position that while the forging operation is going on the upper face of the bar will engage the lower side of the scraper and be cleaned of its scale. Also in the frame D', Figs. 2 and 8, I pivot a rocking shaft, *d'*, and to this rocking shaft I attach a scraper and guide, *s'*, which extends up and forward to a point just beneath the scraper *d*, or on the side thereof toward the point of bite, and its upper end is recessed or boxed, as shown in Fig. 8, to such form that it may, on being thrown up, engage the bar both beneath and on its sides or edges, and thereby hold it in the desired line of feed, as against any tendency to lateral displacement. But as

this guide must engage the bar only while it is being acted on by the dies $c\ c'$, and since at other times it must be out of the way, so that the path will be clear for another bar to be fed in, I provide for raising and lowering it at the proper intervals by means of an arm, d^2 , the forward end of which engages a curved lifter or cam, d^3 , on the end of the lower roll B' . These parts are so proportioned relatively to each other and the other devices described that when the dies $c\ c'$ begin to bite the forward end of the lifter or cam d^3 will engage the end of the arm d^2 and throw up the guide s^1 into its operative position on the bar, as above described. As soon as this pass is ended the lifter d^3 ceases to engage the arm d^2 , and the guide s^1 drops by gravity, or is forced down by equivalent spring, so as to be out of the way of a new feed. In this manner I produce the blank shown in Fig. 5; but in this operation I do not propose to give it the entire amount of forging and shaping desired; but I prefer to do a part of the work at this pass, and complete it in another pass through between the other or outer set of dies. These dies, like the others, have cut-away parts $e\ e'$, but of sufficient size for the feeding through between the rolls of the end m^2 of the blank as previously produced, preparatory to the bite thereon of the convex-faced tongue or die i and the concave-faced groove or counter-die i' . These dies $i\ i'$ engage the blank at the point m^3 , Fig. 6, and they are so proportioned as to still further draw, reduce, taper, and shape the strap end m^4 of the blank, and thereby finish and complete the same by a reverse or backward rolling action.

To insure accuracy and perfectness of product, I employ front and rear guides. The rear guides consist of an upper stationary or fixed guide, b , Figs. 7 and 8, mounted in the ears D^2 , so that its lower face shall take a bearing on the top of the blank.

The lower scraper and guide s^2 has a concave face or seat at its upper or free end, Fig. 8, and such free end comes about under the upper guide b , or on the side thereof toward the point of bite. The opposite end of the guide s^2 is affixed to a rock-shaft, b^1 , and the latter receives, by the arm b^2 and lifter d^3 , the same motions and in the same order relative to the action of the dies $i\ i'$ as is above described relative to the guide s^1 , and for the same purposes. The convex face of the blank being scraped by the guide s^2 at this pass, it comes out of or is delivered from the dies with a sufficiently-good exterior finish.

I will next describe the front or delivery guides used in this pass, more fully represented by enlarged detached view in Fig. 4.

To a bracket, D^3 , I pivot a pair of movable jaws, $G\ G$, the forward or free ends of which are made each with a half-concave, g , so as to form a seat, along which the lower or convex face of the blank will be delivered, the curvature of the seats g approximating as near as may be to that of the exterior face of the

blank. Working immediately above these jaws is a roller-guide, h .

The upper exterior edges of the jaw-shaped guides g are, by preference, hollowed out slightly beneath the roller-guide h , as shown at g^1 . The roller-guide h is mounted in one end of a connecting-rod, h^1 , the other end of which is jointed to an arm, h^2 , and which latter is pivoted to the end of a horizontal post or bracket, h^3 , and is operated by an eccentric lifter, h^4 . The connecting-rod h^1 is steadied in its short range of longitudinal motion by a wrist and slot connection. (Shown at p .)

Another connecting-rod, n , extends from the arm h^2 to a crank, n^1 , on a rock-shaft, n^2 . On the latter are two studs, $q\ q$, which extend up, one on the outside of each jaw G . The inner faces of these studs are made sloping or wedge-shaped in the direction of their forward stroke, and they operate against sloping counter-inclines g^2 on the sides of the jaws G , so as, when thrown forward in the direction indicated by the arrow in Fig. 4, they will close or tend to close the jaws together, and with a back or reverse motion will separate the jaws, or permit of their separation.

It will be observed that the strap part m^4 of the blank widens toward the end last operated on. As the guide-seats g are intended not only to guide the blank in its delivery, but also, in connection with the roller h , to assist in straightening it, it is better that the guide-seats g should separate or spread apart gradually as the blank increases in width, so that the edges of the latter will be well supported in the operations of delivering and straightening; and to this end these guide-seats g should have a spreading motion corresponding to the length and rapidity of taper in the blank. This spreading motion is fixed and regulated by a slight eccentricity, which is given to the lifter h^4 , just sufficient in amount or degree to permit the jaws to spread with the increase of the blank in width.

When the lifter h^4 is not in engagement with the arm h^2 , the preponderance of weight in the parts named, or the use of any suitable form of spring or tool, or the pressure of the parts in engagement at the close of the last previous pass, will cause the jaws G to be most widely separated and the roller h to be at its highest point of adjustment. At this stage of the operation all the devices will be in place for the insertion of the blank.

It is intended that the lifter h^4 should engage the arm h^2 at the same, or about the same, time that the dies $i\ i'$ engage the blank. As soon as this is done the jaw-seats g are forced together, and the roller h is caused to move partly forward toward the rolls, and partly downward, so as to take a firm bite on the blank.

The first end or point of engagement of the lifter h^4 is the one most remote from the center. Hence as this lifter passes around it will gradually ease up on the arm h^2 , with the result of gradually bringing the studs $q\ q$

back, allowing the jaw-seats *g g* to spread, and the roller *h* to move back and up until the operation is completed.

Thus far I have made but slight reference to the straightening operation of the machine, having reserved it for separate mention; but in this last rolling or forging such operation is an important feature of my invention. The blank, while being brought to the form shown in Fig. 6, is supported on its under side at three points by the guide *s*², the lower roll *B'*, and the jaw-seats *g g*, and on its upper side, also at three points, by the guide *b*, the upper roll *B*, and the roller-guide *h*. Hence any irregularities of shape, such as a twist, crook, or bend which the blank may acquire in the forging operations described, will be removed wholly or to a great degree.

The blank shown in Fig. 6, it will be observed, has a well-shaped end. This I secure by the use of male and female shearing-dies *u u'*. The die *i* merges into or terminates in the male shear *u* at the end last in operation, and the counter-die *i'* in like manner terminates in the female shear *u'*, the edge of the end of the former cutting across the edge of the end of the latter, so as to trim off and give a well-shaped end to the blank, as shown in Fig. 6. A recess, *u*², provides room for the waste. But as this shearing operation requires the use of steel shears, I make these shearing-dies separate, as shown, and insert them in the rolls *B B'* in any of the ways known to the art.

It should have been stated at the proper place that the space between the jaws *G*, when the latter are spread apart for the insertion of the blank, is of great convenience, since it affords room for the use of tongs in manipulating the blank.

It will be seen by inspection of the drawings that the second set or pair of forging-dies *i i'* come into an operative relation with each other, or, in other words, begin their bite on the blank at such distance (measured in the direction of the motion) in the rear of the first point of bite of the first pair of forging-dies *c c'* as to admit of the immediate transfer of the blank from one pair of dies to the next, without waiting for another complete revolution of the rolls; and this feature is practically an important one in the use of the machine, in view of the rapidity with which such thin blanks lose their heat. It will also be seen that while this is being done another workman can feed in another bar through the grooves *a a'*, so that with two workmen both sets of forging-dies can be operated continuously as to time and in rapid succession as to order of work.

Some of the features described may be advantageously applied to other rolling or forging machines for kindred purposes, and such uses of the features herein claimed are hereby included within the scope of the present invention.

The form of the guide-seats *g*, as well as the

number of separate parts which go to make up the operative face of such device as a guide, may be varied at pleasure to adapt the same for use in delivering other irregularly-shaped forms of rolled material, provided only such parts be so connected with the running machinery as to be operated automatically wholly or in part; also, as described, the parts lettered *g g* and *h* move simultaneously toward the central line of delivery, and thereby gripe the blank on all sides in straightening it; but it is not absolutely necessary that all these gripping parts should be movable, as some may be stationary in the proper position, and the other or others be caused to move automatically toward them. Also, in the arrangement of the lifting-arms and connecting-rods considerable change may be made within the application of the doctrine of mechanical equivalents.

The tongs which I employ for feeding in the blanks have a laterally-projecting lug on each side, which acts as a feed-gage in connection with shoulders or stops *r r*. (Shown in Fig. 4.) These stops are made at such point that the blank will be fed in with an end, *m*, of the desired length projecting clear of the point of bite. A like stop is made on the guide *s*, as shown at *r'*, Fig. 1.

I claim herein as my invention—

1. In a machine having revolving forging-dies for the progressive reduction of concavo-convex blanks by two or more successive passes, the combination of grooves *a a' e e'*, adapted to the feeding of the blanks on the delivery side, the tongue and groove dies *c c'*, adapted to the partial reduction of the blank, and the tongue and groove dies *i i'*, adapted to further reduce the same blank when the two sets of dies are arranged with the beginning of their points of bite not in the same line, whereby the two sets of dies may be employed in succession on the same blank, and also simultaneously on different blanks, substantially as set forth.

2. The combination of the grooves *e e'*, for feeding in the blank from the delivery side, the tongue and groove dies *i i'*, for finishing the concavo-convex body of the blank, and the removable male and female steel shearing and trimming dies *u u'*, for shearing off to a finished form the end of the finished blank, substantially as set forth.

3. In combination with tongue and groove rolling-dies for shaping irregular blanks, a swinging scraper-guide having a recessed operative face corresponding to that of one side of the blank, a cam, *d*³, and a guide fixed in position during the rolling operation on the opposite side, substantially as set forth.

4. A scraper attached to a rock-shaft and a lifting-arm attached to the same shaft, in combination with a lifter, *d*³, attached to one of the rolls, substantially as described.

5. As a device for delivering or straightening (or both) blanks of irregular form from rolling-dies, guide-seats *g*, adapted to vary their position automatically with the varying

form of the article produced, substantially as set forth.

6. In combination with revolving forging-dies and rear guides, a pair of pivoted jaws, G G, adjusted to and from each other automatically with the varying form of the blank, substantially as described.

7. A straightening device on the delivery side of a pair of rolls or rolling dies, which, by the automatic movement of one or more of its moving parts toward the central line of delivery, is adapted to gripe the blank on all sides, and thereby bring twisted or bent parts of the blank into line, substantially as set forth.

8. An automatically-operating griping device on the delivery side of a pair of rolls or rolling-dies, in combination with an automatically-operated scraper or guide on the opposite side, substantially as described.

9. The eccentric lifter h^4 , as a device for operating, by means of suitable interposed connections, one or more of the movable straightening-grippers $g g h$ on the delivery side of the

rolls, and in combination with such grippers, substantially as set forth.

10. The pivoted jaws G G, adapted to open sufficiently for the insertion of the tongs between them in feeding, and at the same time free to close more or less while the reducing or shaping operation is in progress, in combination with mechanism for effecting such movements automatically at the proper times, substantially as set forth.

11. The combination of lifter h^4 , arm h^2 , connecting-rod n , cranked shaft n^1 , studs $q q$, inclines $g^1 g^1$, and jaws G, substantially as described.

12. The shoulders $r r$, made on and as a part of the jaws G G, and in combination therewith, substantially as set forth.

In testimony whereof I have hereunto set my hand.

JOHN H. ALKER.

Witnesses:

GEORGE H. CHRISTY,
CLAUDIUS L. PARKER.