

E. H. COWLES.  
Feather-Renovator.

No. 201,871.

Patented April 2, 1878.

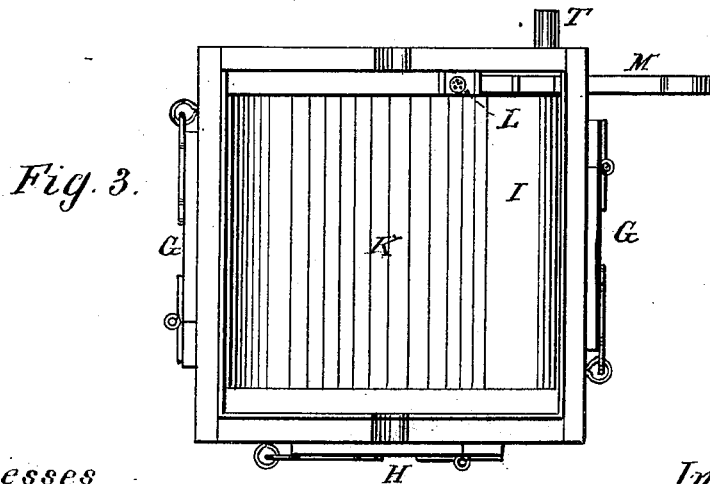
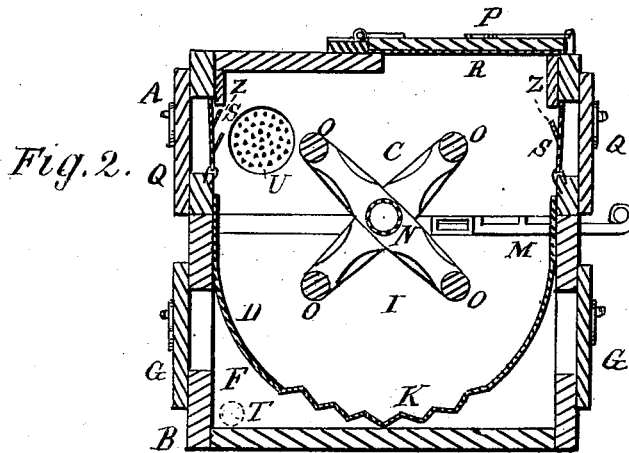
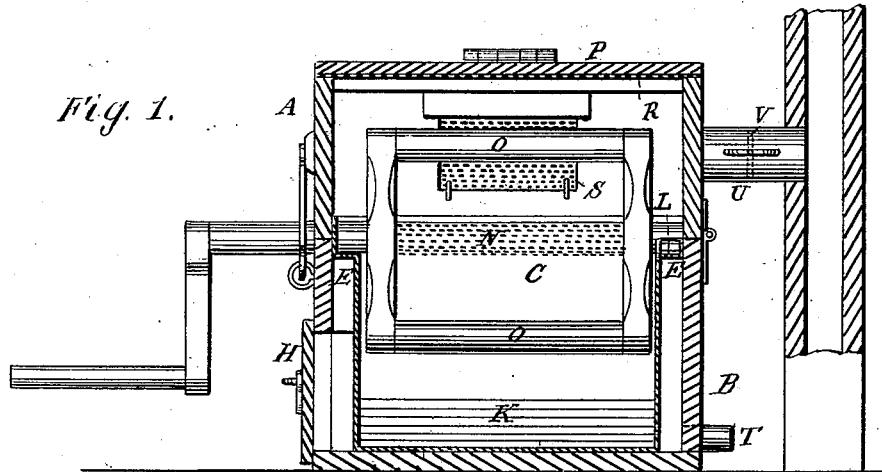

Witnesses  
J. A. Tauberschmidt  
B. Buckingham

Inventor  
Elijah H. Cowles,  
By Theo. Munger  
Atty

# UNITED STATES PATENT OFFICE.

ELIJAH H. COWLES, OF NEWCASTLE, PENNSYLVANIA.

## IMPROVEMENT IN FEATHER-RENOVATORS.

Specification forming part of Letters Patent No. **201,871**, dated April 2, 1878; application filed February 8, 1878.

*To all whom it may concern:*

Be it known that I, ELIJAH H. COWLES, of Newcastle, in the county of Lawrence and State of Pennsylvania, have invented certain new and useful Improvements in Feather-Renovators; and I do hereby declare that the following is a full, clear, and exact description of the same, reference being had to the accompanying drawing, making a part of this specification, in which—

Figure 1 is a longitudinal vertical sectional view of the machine. Fig. 2 is a lateral vertical sectional view, and Fig. 3 is a plan view of the lower section of the machine.

This invention relates to machines for renovating feathers; and consists in the improvements in the construction of the same herein-after more fully set forth, and particularly pointed out in the claim.

In the accompanying drawing, similar letters of reference indicate like parts in the invention.

The shell or casing of the renovator consists of an upper section, A, and a lower section, B, hinged together, as shown, to open upwardly for the purpose of admitting the agitator C to the shell; also to admit of repairs, &c. Within the lower section B rests a removable semi-cylindrical shell, D, of one thickness, of tin, which is made shorter from end to end than the section B, and is provided with flanges E at its ends which permit it to fit snugly within the shell at the top of section B, and to form a steam space or chamber, F, between the walls of the shell C and those of the section B. The lower section B is provided with hinged doors G G and H, the former being located at the sides, and communicating with the steam-chamber F, and the latter located at the end, and communicating with the feather-chamber I.

Corrugations K are made in the bottom of the shell D, to form receptacles for the dirt, and a perforated opening, L, in one of the flanges E, controlled by a slide, M, regulates the admission of the steam from the steam-chamber F to the feather-chamber I.

The agitator consists of a perforated shaft, N, provided with arms O, driven by a crank. The upper section A of the shell has a door, P, in its top, through which the feathers are

introduced to the feather-chamber; and also doors Q Q, one in each side, either of which may be used, one at a time, through which to roll the dried feathers from the feather-chamber. The doors P and Q Q are provided on their inner sides with hinged perforated screens R and S S, to admit air to the chamber I, and at the same time confine the feathers during the operation of drying them, at which time the doors Q Q, at least, are open.

The perforated screens S S are provided with pockets Z, for the purpose of catching the dirt that may be driven against the screens S S during the operation of renovating the feathers. The lower section B of the shell is provided with a steam-inlet, T, near its lower corner, to admit the steam to the steam-chamber F. The upper section A has the large outlet-pipe U, covered on its inner side with a perforated screen, and provided with the valve V, for conducting the steam, odor, &c., from the feather-chamber to the stove-pipe or flue with which said pipe U is connected.

Steam may, if desired, be admitted directly to the feather-chamber by attaching the induction-pipe to the end of the perforated shaft N. Those portions of the walls of the section B which surround the shell D may be lined with tin or asbestos, to increase the heating power of the steam-chamber F.

The operation of the invention is as follows: The feathers are placed in the feather-chamber I through the door P, and steam is admitted to the steam-chamber F through the inlet-pipe T. The slide M is drawn from the perforated opening L in the flange E, and the steam passes from the steam-chamber F into the feather-chamber I, highly heating the steam-chamber in its passage. The agitator is constantly operated to present all of the feathers to the action of the steam; and the dirt, as it is driven from them, is lodged in the pockets Z and the corrugations K, from which it may be removed, when necessary, through the doors Q Q and H. When the feathers have been thoroughly steamed, the slide M is closed and the doors Q Q and valve V thrown open, the screens S S remaining closed to confine the feathers within the chamber I. By these changes a draft will be created, and the steam and odor from the feathers within the feather-

chamber will be quickly carried off through the outlet-pipe U and the flue with which it is connected, thus preventing the odor and steam from entering the room. The agitator is kept in motion during the drying process to prevent the feathers from being burned.

It will be seen that the same steam that is used to cleanse the feathers is also used to heat the steam-chamber F, so the moment that the steam is shut off the drying process begins without changing the steam-connection, thereby saving steam, time, and labor. When the feathers have become sufficiently dry, one of the doors Q is closed and the opposite screen S is opened, and the feathers are rolled out upon the floor to cool.

When it is desired to dry the steam-chamber F, the doors G G are thrown open. The corrugations K may be cleaned through the door H, and the pockets Z through the doors Q Q.

In case repairs are needed, the section A may be swung up, and the agitator and the semi-cylindrical shell D may, either or both, be removed for the purpose.

It will be noticed that by connecting the steam with the end of the perforated shaft N the feathers may be thoroughly steamed; but when this is done, the steam-chamber F is not heated, except by radiation from the feather-chamber I, and the steam must be disconnected from the shaft N and attached to the inlet-pipe T, thereby necessitating a waste of

time and steam, so that it is greatly preferable to cause all of the steam to pass through the steam-chamber F prior to its admission to the feather-chamber I, because when the drying process is commenced the steam-chamber will have become already highly heated by the same steam that has been used to steam the feathers.

Having thus described my improvements, what I claim as new and useful, and desire to secure by Letters Patent, is—

1. In combination with the feather-chamber I of a feather-renovator, the doors Q Q and screens S S, provided with the pockets Z, substantially as and for the purposes set forth.

2. In a feather-renovator, the steam-chamber F, provided with the inlet T, and the perforated opening L, having slide M, in combination with the feather-chamber I, having corrugations K, doors P, H, and Q Q, perforated screens R and S S, the latter having pockets Z, outlet and valve U V, and the agitator N O, substantially as and for the purposes set forth.

In testimony that I claim the foregoing improvements, as above described, I have hereunto set my hand and seal.

ELIJAH H. COWLES. [L. S.]

Witnesses:

HOSEA ALLEN,  
B. S. MCKEWAN,  
J. P. LESLIE.