

E. CRAWLEY.
Machine for Preparing Fly-Leaves for Books.
No. 202,156. Patented April 9, 1878.

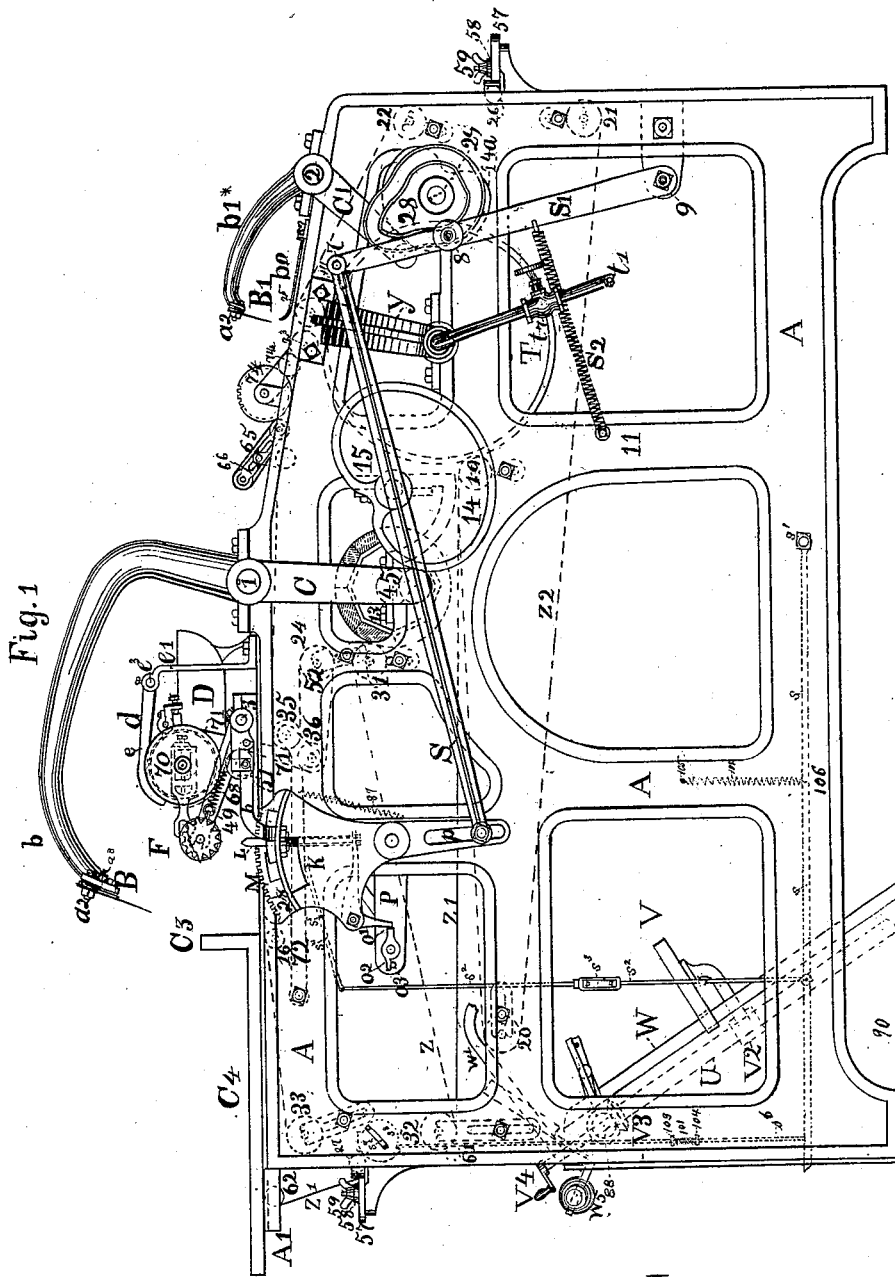

Fig. 1

Attest:
Walter S. Christopher
Joseph Ziffler.

Inventor
Edwin Crawley

E. CRAWLEY.
Machine for Preparing Fly-Leaves for Books.
No. 202,156. Patented April 9, 1878.

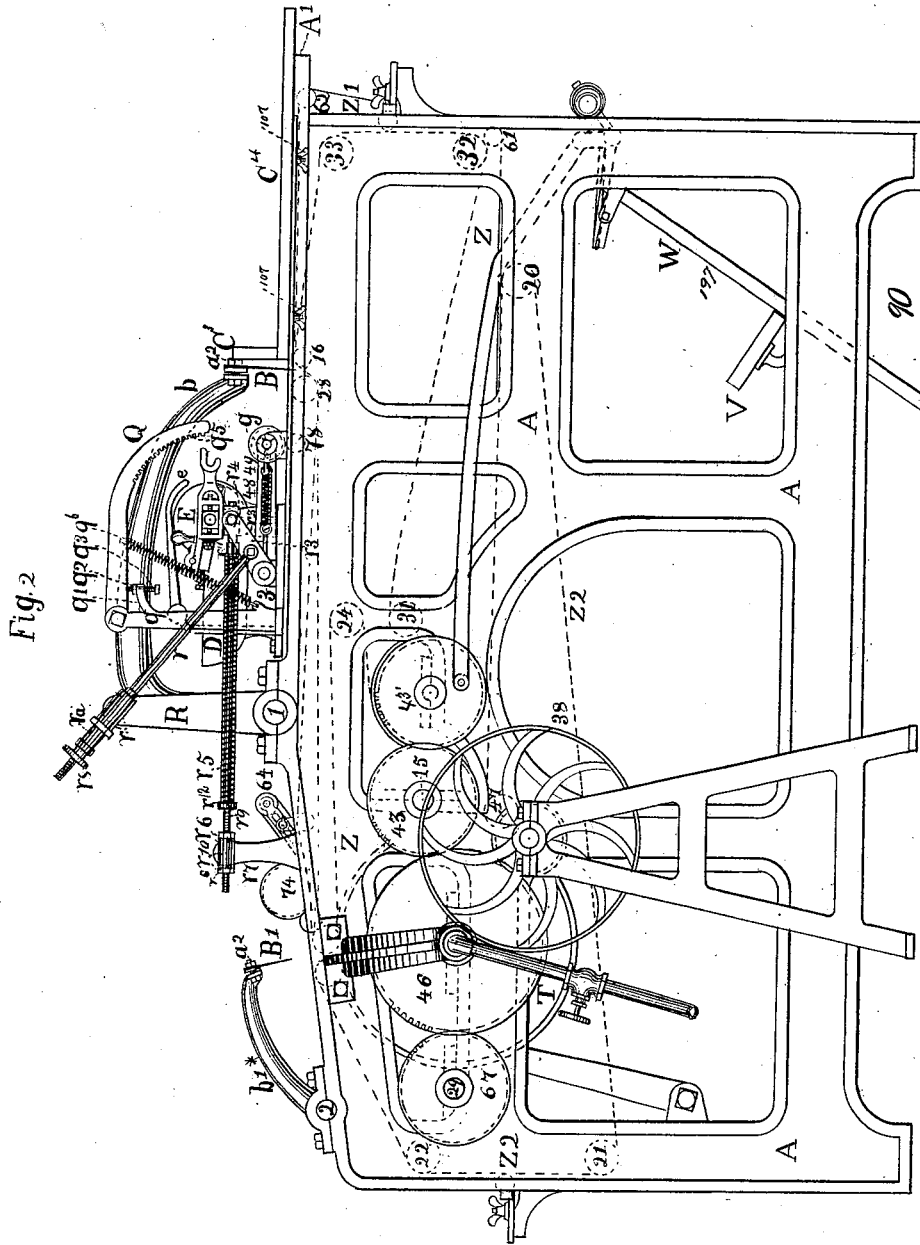

Fig. 2

Attest:
Walter D. Christopher
Joseph Zieffle.

Inventor,
Edwin Crawley

E. CRAWLEY.

Machine for Preparing Fly-Leaves for Books.

No. 202,156.

Patented April 9, 1878.

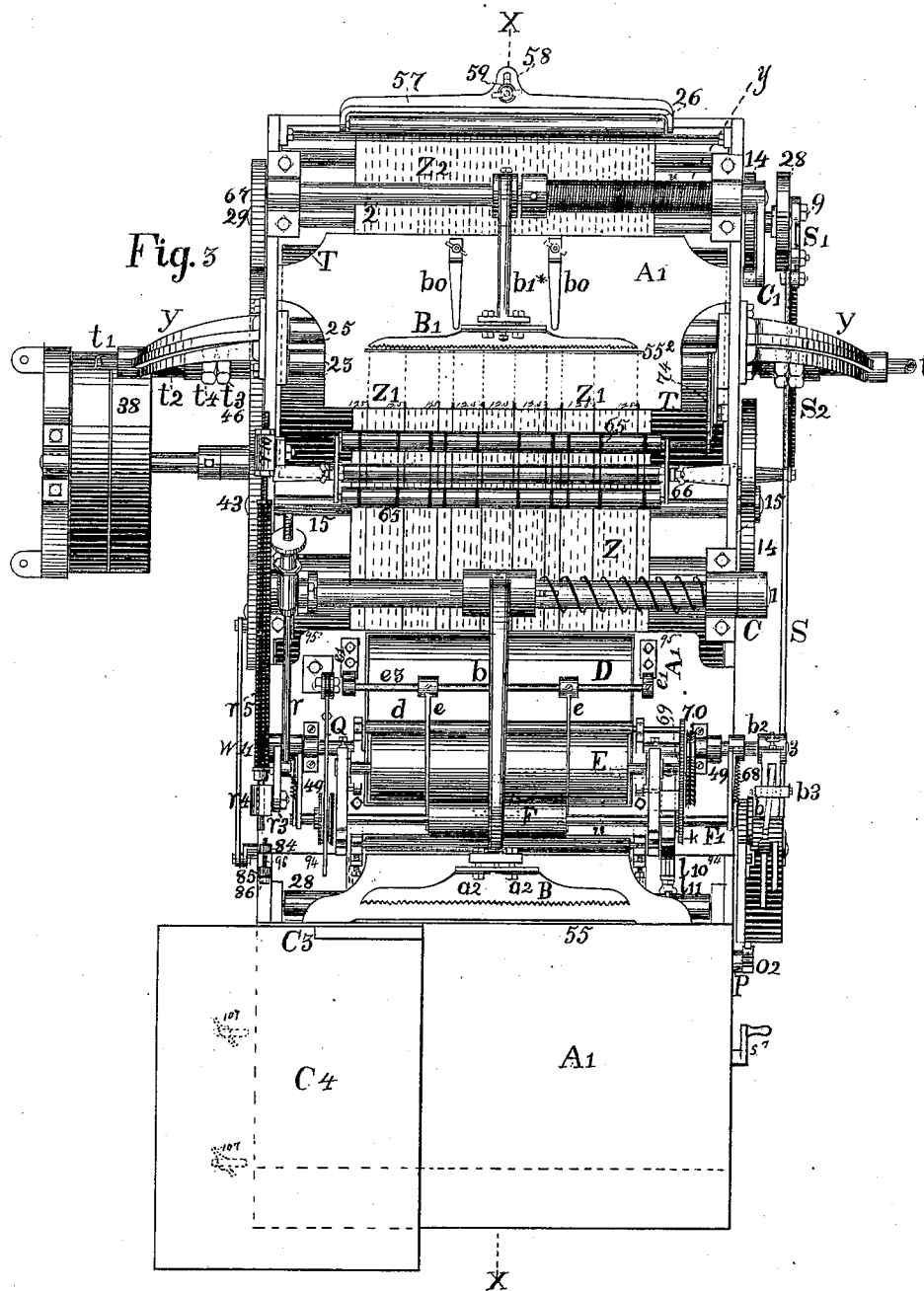

Attest:
Walter S. Christophen
Joseph Zieffle

Inventor
Edurn Crawley

E. CRAWLEY.

Machine for Preparing Fly-Leaves for Books.
No. 202,156. Patented April 9, 1878.

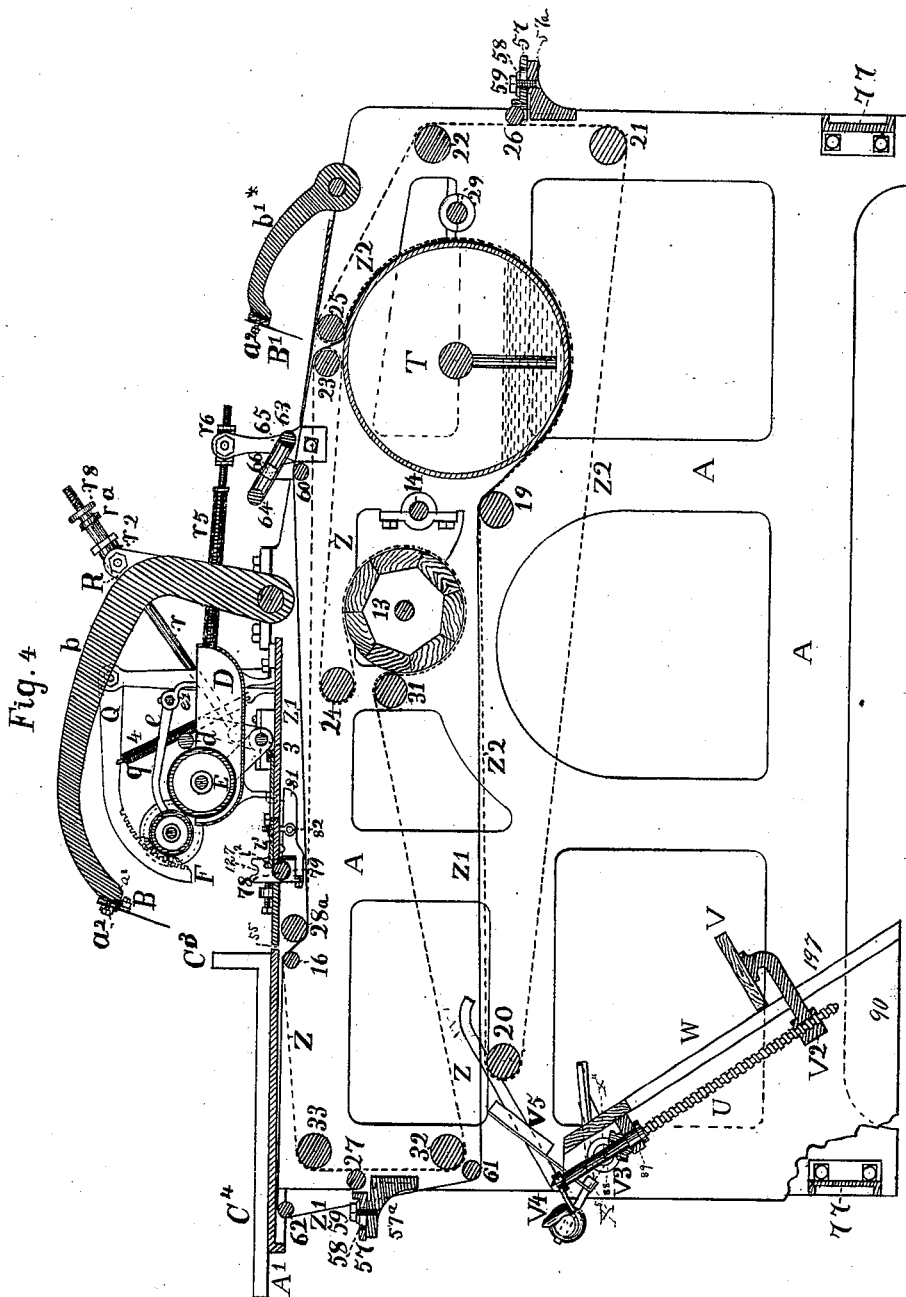

Attest:
Walter S. Christopher
Joseph Ziehl.

Inventor
Edwin Crawley

E. CRAWLEY.

Machine for Preparing Fly-Leaves for Books.
No. 202,156. Patented April 9, 1878.

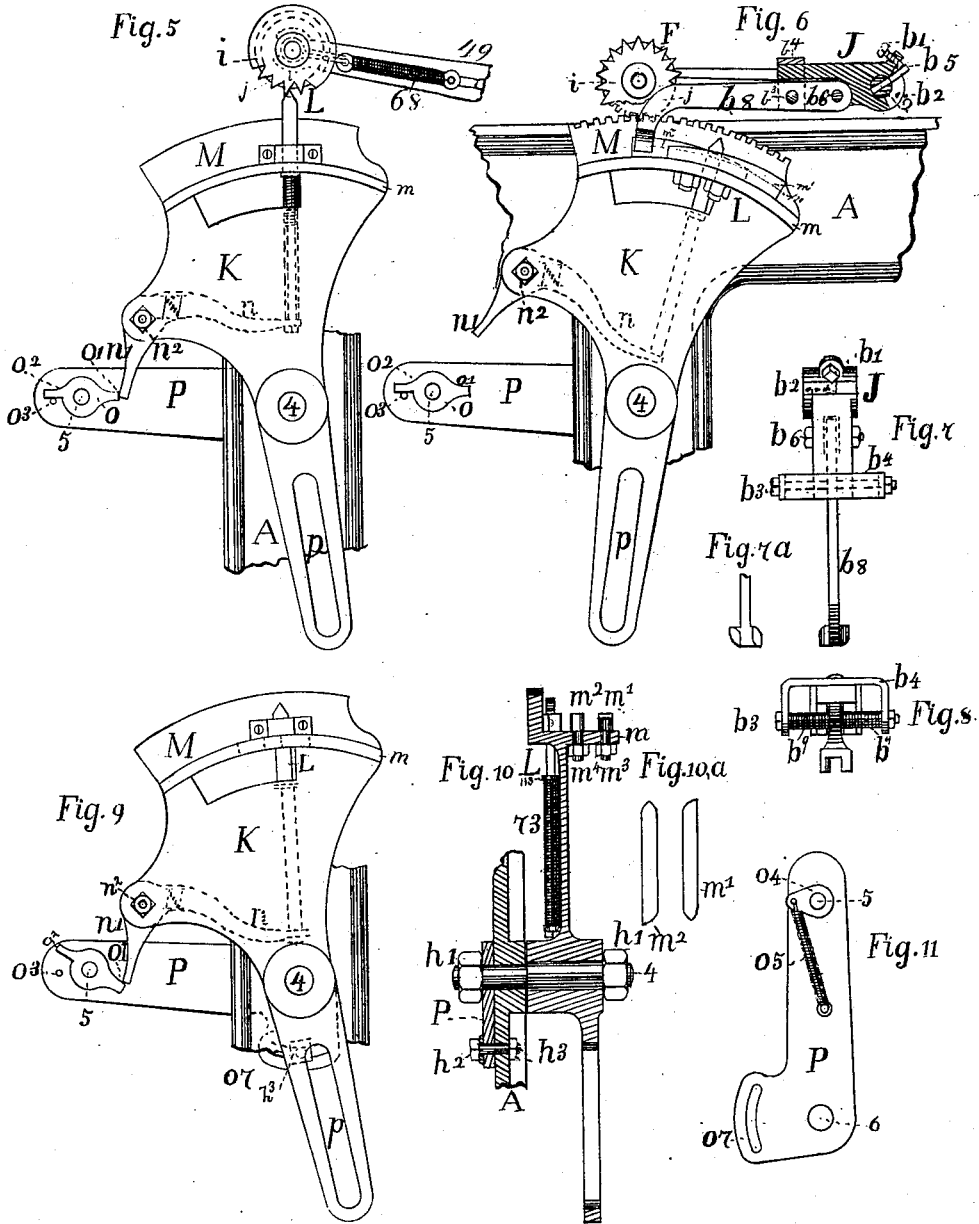

Attest:
Walter S. Christopher
Joseph Ziefler

Inventor,
Edwin Crawley

E. CRAWLEY.

Machine for Preparing Fly-Leaves for Books.
No. 202,156. Patented April 9, 1878.

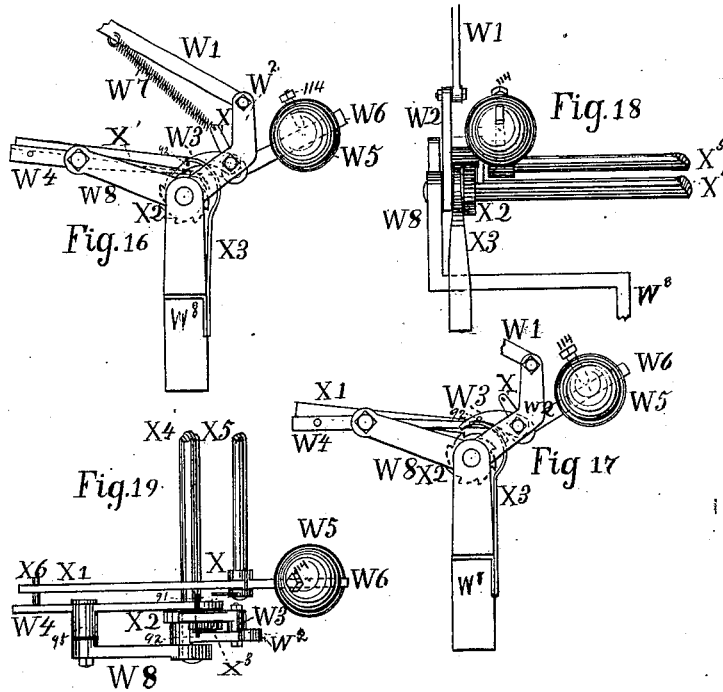
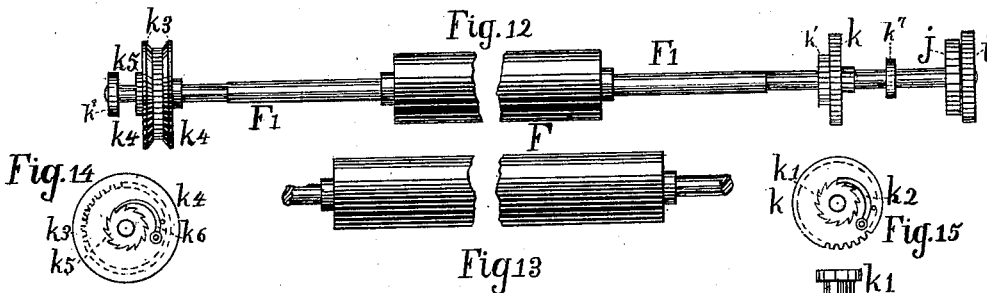
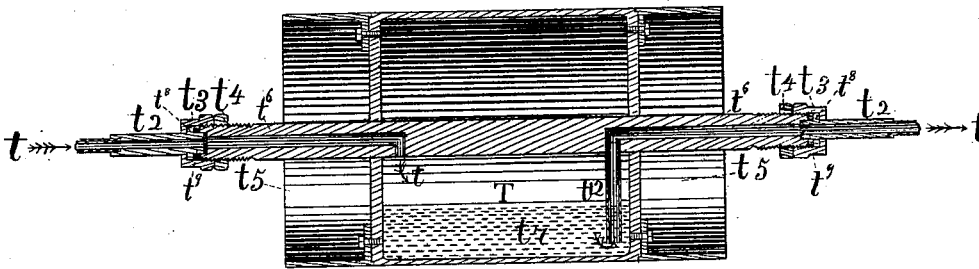
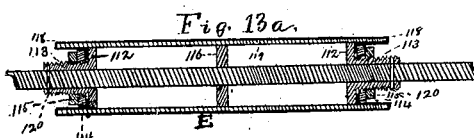

Fig. 20



Attest:
Wm. Christopher
Joseph Ziefler



Inventor
Edwin Crawley

E. CRAWLEY.
Machine for Preparing Fly-Leaves for Books.
No. 202,156. Patented April 9, 1878.

Fig. 21

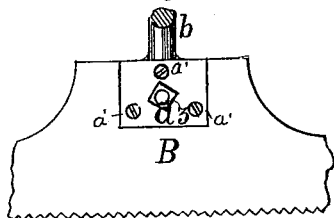

Fig. 23

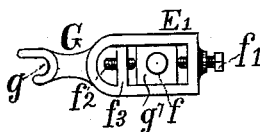

Fig. 22

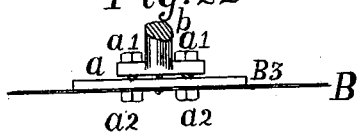

Fig. 24

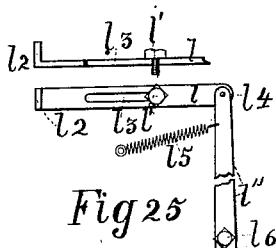
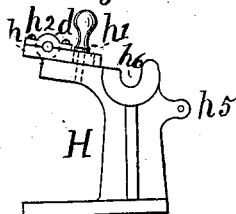
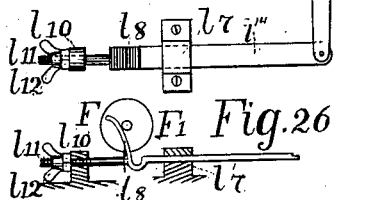
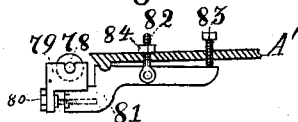

Fig. 27



Attest:
H. S. Christopher
Joseph Zieffle.

Inventor
Edwin Crawley

UNITED STATES PATENT OFFICE.

EDWIN CRAWLEY, OF NEWPORT, KENTUCKY, ASSIGNOR TO JOHN R. DAVEY,
OF CINCINNATI, OHIO.

IMPROVEMENT IN MACHINES FOR PREPARING FLY-LEAVES FOR BOOKS.

Specification forming part of Letters Patent No. **202,156**, dated April 9, 1878; application filed
May 16, 1877.

To all whom it may concern:

Be it known that I, EDWIN CRAWLEY, a resident of the city of Newport, county of Campbell, and State of Kentucky, have invented an Improved Machine for Preparing Fly-Leaves for Books, of which the following is a specification:

This invention relates to the manufacture of books. An examination of many volumes provided with stiff covers will disclose a couple of fly or blank leaves of paper between the title-page and the cover, and show that these are a part of two sheets, the other portions of which have been previously pasted together and pasted on the book-cover, the fold in the sheets coming at the point where the cover meets the book. These sheets form a convenient method of attaching the covers to the book, and at the same time furnishing fly-leaves therefor. The pasting of these sheets together, as aforementioned, has usually been done by hand, and to be nicely performed requires the care of an expert employé. Even then there is great difficulty in evenly distributing the paste and in pasting accurately the sheets as far as the fold. Very often ridges of paste will be found between the sheets, and thus the inner surface of the cover be rendered uneven. Frequently a part of the leaves which should be pasted together will not be thoroughly pasted, and hence, therefore, when pasted to the cover the parts missed by the paste-brush will buckle up in an unsightly manner. Frequently the paste will be applied beyond the fold and on the fly-leaves, the latter thus being made to adhere, when they should be separated. When inexperienced hands are employed the evil is increased.

My invention provides a machine whereby the pasting of the leaves together, the folding, and drying of the same are automatically accomplished, these various functions being performed with great rapidity and accuracy. Skilled labor is thus dispensed with, any employé of ordinary intelligence being able to feed and manage the machine.

In particular, my invention consists in a novel method of actuating the pasting-roller and a novel mode of applying the same to the paper to be pasted. By the devices for carrying out

this method I am enabled to paste the paper at the exact points required, and to prevent the paste-roller, after having received an even layer of paste from the distributing-roller, from leaving lines or heaps of paste thicker than the average thickness of the paste-layer, thereby obtaining an evenly thick layer of paste over the entire portion of the paper which is pasted.

Also, in an improved device which receives the papers as they are delivered from the machine, and packs them in order in a pile ready for easy removal by the quantity from the machine.

Further, in the combination of the various parts of the machine with each other, whereby a successful, rapid, and efficient instrument for the performance of the functions of pasting, folding, drying, and packing the waste papers is obtained.

In the accompanying drawings, Figure 1, Sheet 1, is a side elevation of a machine embodying my invention, the front of the same being at that end which is at the left hand of the drawing. Fig. 2, Sheet 2, is an elevation of that side of the machine opposite to that shown in Fig. 1, the front of the machine being at that end which is at the right hand. Fig. 3, Sheet 3, is a top view of the said machine. Fig. 4, Sheet 4, is a vertical longitudinal section of the machine, said section being taken at the line X X of Fig. 3. Fig. 5, Sheet 5, is a view of the exterior of the guide pinion-wheel of the pasting-roller and the spur and the lever operating the said roller, and their accompanying devices, whereby the teeth of the motive-pinion are made to accurately mesh with the teeth of the spur upon each descent of the former. Fig. 6, Sheet 5, is a view of the devices shown in Fig. 5, and also the devices for temporarily lifting or tilting the pasting-roller while the latter is pasting the paper. The objects for which the roller is thus lifted will be fully set forth hereinafter. Fig. 7, Sheet 5, is a top view of the device aforementioned for lifting the pasting-roller, and Fig. 7^a is a bottom view of the lever which slides on and is operated by the tilting device. Fig. 8, Sheet 5, is a front view of the device shown in Fig. 7. Fig. 9, Sheet 5, is a side elevation of the devices shown in Fig. 6, (ex-

cepting the pinion-wheels and attachments of the pasting-roller and the levers operating the same,) showing another position of the spur-rod and the gear operating the pasting-roller in meshing accurately with the gear of the ratchet. Fig. 10, Sheet 5, is a central sectional elevation of the devices shown in Fig. 9. Fig. 10^a is a top view of the tilting slides or trippers shown in Fig. 10. Fig. 11, Sheet 5, shows the inside of the adjustable arm which holds the lever for initiating the upward movement of the said spur-rod. Fig. 12, Sheet 6, is a view of the pasting-roller and the mechanism attached to its shaft. Fig. 13, Sheet 6, is a view of a pasting-roller of a length different from that shown in Fig. 12. Fig. 13^a is a section of the feed-roller. Fig. 14, Sheet 6, is a side elevation of the gearing at that end of the roller which is at the left hand in Fig. 12. Fig. 15, Sheet 6, is a side elevation of the gearing shown in Fig. 12, as between the right-hand end of the pasting-roller and the gearing on the end of its shaft. Fig. 16, Sheet 6, is an elevation of one side of the principal mechanism operating to receive and pile the folded papers, showing the ratchet-wheel in operation. Fig. 17, Sheet 6, is an elevation of the same side of the same mechanism, the ratchet not being in operation. Fig. 18, Sheet 6, is a view of that end of same which is at the right side in the preceding figure. Fig. 19, Sheet 6, is a top view of the mechanism displayed in the figures last named. Fig. 20, Sheet 6, shows a vertical central section of the cylindrical steam-reservoir employed to dry the papers, and its influent and effluent pipes, said section being taken through the length of the same. Fig. 21, Sheet 7, exhibits the rear of the folding-knife; and Fig. 22, Sheet 7, a top view of the same. Fig. 23 is a side view of the arms which regulate the distance between the paste-feed roller and the paste-roller. Fig. 24, Sheet 7, shows a side elevation of the device for regulating the distance between the paste-feed roller and the roller which controls the amount of paste which the paste-feed roller shall receive from the paste-reservoir. Fig. 25 presents a top view and sectional views of the mechanism for gaging the paper when fed to the machine. Fig. 26 is a side elevation of the roller operating the gage referred to in the preceding figure. Fig. 27 is a side elevation, showing the mechanism for adjusting the roller which lies beneath the pasting-roller and supports the paper, so as to receive the paste at the desired place.

In the drawings A, Fig. 1 indicates the frame of the machine, and A' the top of the same. B is the first folding-knife attached to lever *b* by a device for adjusting the same in any direction. This device (see Figs. 3, 21, and 22) consists of the securing-bolt *a*³, and two or more set-screws, *a*¹, Fig. 22, passing through the flanges *a* of the lever *b*, and bearing against the strengthening-plate B³, and consists further of two set-screws, *a*², screwed

through the folding-knife and into the plate B³, from front to rear, their location being on a vertical line midway between the bolts, *a*¹, and equidistant above and below a plane passed through the axes of the said bolts.

The lever *b* is attached to a shaft, 1, Fig. 1, journaled at the top A' of the machine, and in the rear of the paste devices, and operated by a lever, C, attached to its right-hand end. A cam, 14, operates lever C by means of a loose pulley or roller, 45, journaled to lever C near its lower end. The cam 14 is of such a shape that, during its revolution, it raises the folding-knife and then permits the latter to descend by its own weight aided by spring *r*⁵, Fig. 2. Cam 14 is operated by shaft 15, which is operated by gear 43, Fig. 2. The latter is in turn operated by gear 46, centered on the shaft of the drying-cylinder T, and the latter gear, viz., 46, is operated by the gear 47 on the shaft of the operating-pulley 38.

The second folding-knife B¹ is attached to lever *b*¹, attached to axis 2, journaled at the top of the table, and operated by lever C', operated similarly to lever C by a cam, 14^a, similar in shape to the cam 14, the said cam 14^a being operated by shaft 29, rotated by the gear 67, Fig. 2. Attached to shaft 2 is a spring, *y*, Fig. 3, which aids the arm *b*¹ in its descent. This knife B¹ is rendered adjustable on the lever *b*^{1*} by a device similar to that whereby knife B is attached to lever *b*, and shown in Figs. 21 and 22. The usual lateral guide C⁴, for correctly lining the paper under the first folding-knife, is shown in Figs. 1, 2, 3, and 4, and is made sufficiently broad to serve as a table for the reception of the sheets which are to be fed to the machine. A guard, C³, attached to the rear edge of the table, prevents the sheets from slipping unwittingly into the machine. The reservoir D, for the retention of a considerable quantity of paste, stands upon the top A' under lever *b*.

The lower half of the paste-feed roller E is set in the reservoir, (see Figs. 1 and 4,) the axle of said paste-roller being, near the level of this reservoir, in an open journal-seat, *h*⁶, (see Fig. 24,) supported on standard H. The periphery of the feed-roller E is preferably of cloth. Directly in the rear of the feed-roller E, and a little above the paste-reservoir, is a roller, *d*, for regulating the amount of paste which the paste-roller is to receive. This roller may properly be termed the distributing-roller. It lies parallel with roller E, and turns in bearings, which may be adjusted nearer to or farther from the feed-roller.

This adjusting device consists (see Fig. 24) of the seats *h*, in which the distributing-roller is placed adjustable on the arms of standard H. Through a longitudinal slot in the journal-seat passes a set-screw, *h*¹, having a sufficient flange below its operating-head to engage the said seat on either side of the flange, and provided below the flange with a screw-thread, which passes loosely through the slot and engages a female screw in standard H.

Roller *d* is preferably of brass. Scrapers *e* (see Figs. 1, 2, 3, and 4) are each supported on a transverse rod, *e*³, supported on up-rights *e*¹. The scrapers are secured to the rod by set-screws, and are capable of adjustment by the said set-screws at any desired point along their supporting-rod *e*³ to accommodate the different lengths of pasting-rollers to be employed. These scrapers are so adjusted that one of them shall press against one end of the paste-roller, and the other against the other end of the paste-roller; so as to scrape the paste off the ends of the paste-roller.

The paste-feed-roller E consists of a cylinder, 119, (see Fig. 13^a.) into which are driven two (2) or more diaphragms, 112 112 and 116, and properly fastened in position. Hubs 113 are cast on diaphragms 112, and threads tapped on the hubs. The cloth 118 is brought over the edge of cylinder 119, and ring 114 is slipped over the hub 112 onto the cloth, and nut 115 screwed down onto the ring, thereby tightening the cloth and holding it in place. The pin 120 passes through the hub 113 and the shaft of roller E, so as to hold the roller in position.

The paste-roller F may be constructed similarly to feed-roller E.

The paste-roller does not touch the feed-roller as it receives paste; but there is a slight distance between them, somewhat less than the thickness of paste on the feed-roller, (this thickness is determined by distributing-roller *d*.) and consequently an even layer of paste sticks to the paste-roller, and this layer is thicker than could be obtained if the rollers touched.

The shaft F' is supported by and rotates in the arms 49, by which it is intermittently carried into the open sockets *g* of the arms G. (See Fig. 23, Sheet 7.) The arms G swing loosely on the shaft *f*, Fig. 23, the distance of the sockets *g* being adjusted by means of set-screws *f*¹ *f*² bearing on the sliding bearing *g*⁷ of the arms. It is kept from slipping out of these open sockets by the tension of the springs 68, attached each at one end to the shaft of the paste-roller, and at the other to an eye on arms 49. (See Figs. 1, 3, and 5.) The arms 49 are at their other ends attached to the axis 3, which latter is operated by the lever *r*³, Fig. 2, which, in turn, is operated by the rod *r*, pivoted at one end to the lever *r*³, and has screwed on its other end a sleeve, *r* *a*, which slides through sleeve *r*¹, which latter is pivoted to the lever R at its top. (See Fig. 2.) The sleeve *r* *a* is held in position by the nut *r*⁸, which prevents the sleeve *r* *a* from sliding off the rod, and compels the latter to rise. When the lever R is moved back said nut *r*⁸ enables the amount of throw of the lever *r*³ to be adjusted. Pivoted at the upper end of the lever *r*³ is a sleeve, *r*⁴, through which passes a rod, *r*⁹, on which is a spring, *r*⁵. This rod at its rear end passes through a sleeve, *r*¹⁰, pivoted on the standard *r*⁷, supported on the

table A'. The position of the rod *r*⁹ in the latter sleeve is adjusted by means of the nuts *r*⁶. On the forward end of the rod *r*⁹ is a thimble, *r*¹¹, which slides in a groove in rod *r*⁹, and is prevented from going too far forward by the groove ending. On the rear end of the rod *r*⁹ is the nut *r*¹², which regulates the pressure of the spring *r*⁵ on the thimble *r*¹¹.

Between the spring 68 and the paste-roller on the shaft of the latter are a number of gear-wheels. (See Fig. 12, Sheet 6.) Near the right-hand end of the roller is the ratchet-wheel *k*¹, screwed to shaft F', and next is the pinion *k*, capable of turning independently of the shaft F', and provided with a click, *k*², engaging the ratchet-wheel *k*¹, whereby the pinion *k* imparts motion to shaft F' in one direction, and revolves loosely on the shaft F' when moved in the opposite direction. Ratchet *k*¹ and gear *k* are so arranged that as the shaft F' is lifted by lever 49 the gear *k* will engage spur 69, centered on the shaft of the paste-feed roller E. The manner and purpose of their engagement will be explained hereinafter. Second on the shaft F' is the collar *k*⁷, which lies just inside of socket *g*¹, when the shaft of roller F lies in socket *g*¹ and acts as a guide to keep roller F in position. There is a similar collar, *k*⁸, on the other end of shaft F'. Next on the shaft are pinion *j* and guide-wheel *i*, whose use will be explained hereinafter.

On the other end of the shaft is a pinion, *k*⁴, whose teeth *k*³ mesh with the teeth *q*⁵ of the arm Q, Fig. 2. Arm Q and its attachments and uses will be described hereinafter. The pinion *k*⁴ works loosely on the hub of ratchet *k*⁵, and the click *k*⁶, attached to pinion *k*⁴ and working in teeth of ratchet *k*⁵, compels the shaft F' to turn in one direction when the pinion *k*⁴ turns in said direction, but does not affect the motion of the shaft when the pinion turns in the other direction. This arrangement of pinion *k*⁴ on the hub of ratchet *k*⁵ enables them to be removed easily from shaft F'. When a roller of different size from that on the shaft is to be used, the collar *k*⁸, pinion *k*⁴, and ratchet *k*⁵ are slipped off, and the new roller put in place; then the pinion, ratchet, and collar put back. By this arrangement a shaft with complete attachments for each roller is avoided. The paste-feed roller is operated by a pulley, 70, on the shaft of said paste-feed roller, said pulley being operated by a cord, 71, passing on one side of the pulley 51, and around pulleys 36 and 52 and 35, pulley 52 being the operating-pulley on the shaft on which roller 24 (see Fig. 4) is fastened, and rotated by the cloth Z. (See Fig. 4, Sheet 4.) The object of pulley 51 is to pass the cord out of the way of the operating mechanism. The cord is tightened by the weight of the lever 72, aided by spring 87, attached to lever 72 and frame A. If lever 72 is heavy enough, spring 87 may be dispensed with. Instead of a spring, any suitable elastic device may be used to act upon lever 72, as described.

Said lever holds the pivots on which the small rollers 35 and 36 revolve, and is pivoted at the other end to the inside of the frame A.

To return to the shaft F^1 of the paste-roller F, Fig. 12, Sheet 6. The teeth of pinion j are of a size to mesh with the teeth of the spur M (see Fig. 6, Sheet 5) of device K. The guide-wheel i has the same number of teeth as pinion j , the teeth of the former being opposite the interdental spaces of the latter. At the side of the spur M, Fig. 6, is a hollow guide, through which plays the spur-rod L, (see Figs. 5, 6, and 9,) raised by a bent lever, N, pivoted at n^2 , and consisting of the limbs n and n^1 , the end of the former being attached to the end of the rod L. The lower limb n^1 of the lever N is arranged to impinge endwise upon the arm o^1 of the device o , pivoted on journal 5, and provided with another arm, o^2 , which is prevented from being retracted beyond a certain distance by means of a stop, o^3 , fixed on the arm P. To the journal 5 on the other side of arm P is fixed at right angles to the length of said arm, and pointing downward, a lever, o^4 . A spring, o^5 , Fig. 11, strained between a point near the middle of the arm and the end of the lever, tends to keep the end o^2 of device o always close against the stop o^3 . A spring, 73, encircling the spur-rod L, and compressed between a flange, 113, on the lever below the spur M and the lower end of the rod, tends to keep the rod L retracted to below the edge of the spur M. Arm P, before mentioned, is secured to the frame by bolt 4, and contains a provision for adjusting the end bearing the device o with reference to arms n n^1 by means of the curved slot o^7 , and a bolt, h^2 , passed through the said slot into the frame, and fastened on the outside of the frame A by a nut, h^3 . A longitudinal slot, p , Fig. 9, in the lower portion of the device K, which extends below axle 4, allows the end of operating-rod S (shown in Figs. 1 and 3) to be shifted along the same, and fastened at any point thereon, and thus alter the length of the arc described by the spur M.

Lever S' , (see Fig. 1,) fulcrumed to pivot 9 and pivoted at 7 to the other end of rod S, receives its motion by means of a roller, 8, journaled on a rod extending from the inside of this lever, said roller rotating in a channel in the side of the operating-cam 28. This cam receives a rotary motion from shaft 29, the latter being rotated by the gear 67. (See Fig. 2.)

The device for tripping the paste-roller consists as follows: The rear end of lever J, (see Figs. 6 and 7,) journaled on shaft 3, is provided with a heel, through which is screwed a set-screw, b^1 . The end of this set-screw impinges against a pin, b^5 , fixed in the shaft 3 when the paste-roller is distributing the paste over the paper.

A lever, b^8 , is pivoted at its rear end to lever J by means of a bolt, b^6 . At its forward end lever J has a transverse extension, b^4 , Fig. 8, provided with downward-extending flanges, which receive the ends of a bolt, b^3 , the latter

being secured in position by a nut screwed outside of one of the flanges upon the bolt. This bolt passes through the lever b^8 , the hole in the latter being sufficiently large to allow the lever much lateral play. On each side of the lever b^8 and encircling the bolt b^3 , and compressed between said lever and the flange of extension b^4 , are springs b^9 . These springs operate to keep the lever b^8 , when at liberty, directly in the center of the guides m^2 and m^1 . (See Fig. 10^a.) In the forward end of the lever is a slot. The flanges forming this slot are beveled, as shown in Figs. 7^a and 8. The width of the slot is that of the trippers m^2 m^1 . The latter are situated on the top of the flange m , and parallel to the spur M, and are fastened to the flange by screw-bolts m^3 and m^4 , passing through the flange m . The inside rear left-hand edge of the tripper m^1 and the inside forward right-hand edge of the tripper m^2 , and the inside and outside rear end of tripper m^2 and inside and outside forward end of tripper m^1 are beveled, as shown in Fig. 10^a. The upper edges of the trippers do not form arcs of a circle concentric with the device K; but the forward end of tripper m^2 and rear end of tripper m^1 are raised above that line which would form the arc of a circle concentric with spur M, and which is represented in Fig. 6 by the line 100. Consequently the lever b^8 is raised as the ends of the trippers pass through the slot. This raises lever J, and the bolt b^1 , impinging against pin b^5 , turns the shaft 3 slightly, and thus raises the paste-roller, the object of which will be explained hereinafter.

In the lever J there is a slot, b^2 , so as to allow the pin b^5 a backward motion when the shaft 3 is rocked in the backward direction.

In the top A' of the machine a transverse slot, 55, allows the first folding-knife to pass through the top, so as to fold the paper. A similar slot, 55², is found beneath the second folding-knife B^1 . Immediately beneath the slot 55 is the cloth Z, (see Figs. 3 and 4,) which, with the twines or tapes Z^1 , runs over the roller 16 and under roller 28^a. These rollers lie on opposite sides of the folding knife when the latter is down. Thence the cloth extends rearward around roller 23, and then forward around roller 24; thence around roller 13; thence upon roller 31, and forward around roller 32; then upward upon and over roller 33, back to roller 16. The rollers 16 and 28^a are of different sizes, the forward one, 16, being the smaller. The object of this is to render the portion of the cloth between the two rollers as nearly vertical as may be necessary to secure the sheets being caught between the cloth and twines on the one side and roller on the other. This could be accomplished by rollers of the same size by elevating the front one and pushing it toward the second; but in the present case, on account of the top plate, the front roller cannot be elevated, and this result is obtained by using rollers of different sizes. These two rollers are so made that the distance between them can be regulated ac-

ording as more or less pinch is necessary. The amount of pinch required depends upon the thickness and quality of the paper used.

A roller, 27, for the purpose of counteracting the tendencies of the cloth to pass to the sides of the machine on the rollers over which the said cloth travels, is placed between rollers 32 and 33, and is arranged to press from the outside, at will, against any portion of the cloth Z, by means of a device such as is shown in connection with roller 26 (see Figs. 3 and 4) at the other end of the frame. The roller 27 is journaled in a holder, 57, provided at its middle with a slotted arm, 58, and secured in position by a set-screw, 59, the shaft of which, passing through the slot, screws into an arm, 57^a, on the end of the frame A. The twines or tapes Z¹, passing over the roller 16, but upon the cloth Z, pass under roller 28^a, then over roller 60, then over roller 23, and under roller 25, thence around the drying-cylinder T, over roller 19, forward around roller 61, and up around roller 62, thence back to roller 16.

The second cloth Z² passes over roller 25 from rear to front, thence around the rear of the drying-cylinder T, thence over roller 19, forward to roller 20, around which it passes, and then goes rearward, and, running under and up around roller 21, passes over roller 22, back to roller 25. A roller, 26, and accompanying devices 57, 57^a, 58, and 59, previously described, operate to keep this cloth from running to either side of the machine. The first cloth Z is operated by roller, or, more properly, cylinder, 13, which is centered on the shaft of gear 43', Fig. 2. This latter gear receives its motion from gear 43, which, in turn, is operated by gear 46, centered on shaft of drying-cylinder, and gear 46 receives its motion from gear 47 on the shaft of driving-pulley 38. The twines or tapes Z¹ and second cloth Z² receive their motion from the drying-cylinder T, whose moving gearing has just been described.

A set of twines, 65, are stretched upon rollers 64 and 63, and are rotated by the roller 63, operated by any suitable gear. The ends of these rollers are journaled in the links of 66. As seen in Fig. 1, these links are so made as to regulate the distance between roller 63 and top of table. By this means the pressure of roller 63 on the paper which passes under it is adjusted.

In the front part of the machine is the apparatus for packing the folded papers. It is operated as follows: The pitman (see Fig. 2) moves the bent lever W², attached at one end to pitman W¹, and fulcrumed loosely at the other end to the shaft X⁴. Attached to lever W² is pallet W³, which latter imparts motion to ratchet X². This ratchet X² is firmly attached to shaft X⁴. Attached to the sides of pallet W³ are pins 91 and 92. Between the ratchet X² and lever W² is a pallet-arrester, X³, which is preferably elastic. Pallet-arrester X³ is attached at its lower end to the arm W⁶, which latter supports one end of shaft X⁴.

The other end of shaft X⁴ and shaft X⁵ are entirely supported by stand 90. A lateral extension of arm W⁶ (shown in Figs. 19 and 17) supports the fulcrum 93 of the lever W⁴. Attached to the inner side of the rear portion of lever W⁴ is a pin, X⁶, against which impinges the lever X¹. This lever X¹ is attached to the shaft X⁵. Lever X¹ has an arm, W⁶, branching from it. On shaft X⁵, adjoining lever X¹, is arm X, projecting from a collar which fits on shaft X⁵. By means of this collar and a binding-screw arm X is fixed in any position on shaft X⁵. To arm X⁵ is attached one end of the spring W⁷, whose other end is fastened to pitman W¹. On the arm W⁶ is the weight W⁵, which can be fastened in any position along the arm W⁶ by means of the set-screw 114.

In the middle part of the front of the machine, and centered on shaft X⁴, is the bevel-gear 88, Fig. 4, which rotates the bevel V³. Ratchet X², Fig. 16, allows the machinery to turn the shaft X⁴ in but one direction. The screw U, headed by bevel V³, works in the collar 89. Screw U is an ordinary right-hand male-screw, which engages with the female screw in the head V² of the table V. The arm from head V², supporting table V, works in the slot W, located in the inclined side 197 of stand 90, the said slot W acting as a guide.

The top A' of the machine is divided in three portions. The front edge of the middle portion is marked by the line 94 94, Fig. 3, and the rear edge of this same portion by the line 95 95, Fig. 3.

The drying apparatus consists of a cylinder, T, (See Figs. 20 and 4,) to each end of which is attached an extension, t⁵. Through holes in the ends of cylinder T is driven the shaft t⁶. This shaft has a hole, t, bored partially through from each end, as shown in the drawing. Openings are made in the sides of the shaft to meet the inner end of each of these holes, as seen in Fig. 20. In one of these last-mentioned openings a tube, t², is screwed, through a hole made in the outer portion of the cylinder, said hole being afterward plugged up. This cylinder T revolves in bearings in the frame A, and arms Y, extending from frame A, support the portions t².

The arrangement for making the roller 78 parallel to the paste-roller is shown enlarged in Fig. 27. Roller 78 is shown in Figs. 3 and 4. The bolt 82, Fig. 27, is pivoted to the arm 81, and, passing through a hole in the plate A', is screwed in position by a nut, 84. A screw-bolt, 83, passes through a threaded hole in plate A' in the rear of bolt 82, and impinges against the end of arm 81, depressing the rear end of said arm until the forward part is pressed hard against the edge of A'. By raising or lowering bolts 82 and 83 the roller 78 is lowered or raised to any desired position. Bolt 80 works in a collar in block 79, and adjusts roller 78 laterally.

The arrangement other than table C⁴ for gaging the paper fed to the machine is shown

in Figs. 25 and 26 and 3 and 4. The tongue l^2 is opposite the center of the roller 78, and near its edge, (See Fig. 4,) when paper is fed to the machine, and when the paste-roller descends this tongue l^2 is drawn back by the mechanism shown in Figs. 25 and 26. Arm l is pivoted at l^4 to lever l^3 , which is fulcrumed to the plate A^1 at l^6 , and is pivoted at its other end to arm l^4 , which passes through the guide l^7 and terminates in a projection, l^8 . The projection l^8 may be made with a depression at the bottom, as seen in Fig. 26. This depression is for the purpose of allowing the shaft of the paste-roller to descend to its proper position; but this result could be obtained by lowering the whole rod l^7 .

In the arm l is a slot, l^3 , through which passes a screw-bolt, l^1 , which screws into the top A' of the machine.

Attached to the lever l^3 and plate A' of machine is spring l^5 , which tends to force the arm l forward, and this forward motion is regulated by means of the screw-bolt l^1 and set-screw l^2 .

The arm Q , Fig. 2, is pivoted at one end to the top of standard q , said standard being fastened to the top A' of the machine. A spring, q^6 , fastened at one end to lower part of standard q , and at the other end to the arm Q , serves to hold the arm Q against the bolt q^3 .

The stand 90, Fig. 4, is fastened to the floor, and serves as a means for attaching the device for packing the folded papers. The arm W^3 , Fig. 18, is attached to the side of the stand 90.

Attached to the inside of the upright right-hand portion of frame A is a foot-lever, s , Fig. 1, fulcrumed at the bolt s^1 , which fastens it to the frame A . Pivoted to lever s is rod s^2 , provided with device s^3 for regulating its length. The rod s^2 is pivoted to the end of the lever s^4 , which is fulcrumed at s^5 to the frame A . The other end of lever s^4 presses against the under side of lever 72, for the purpose of raising it when necessary, and thus so loosening the belt which operates the paste-feed roller as to stop that part of the machine. When the foot-lever s is not depressed, the spring 87, attached to lever 72 and frame A , pulls lever 72 down and tightens the cord which operates the paste-feed roller. Over the front of the lever s is a small upright rod, s^6 , which impinges against cam s^8 . The cam s^8 is provided with a crank, s^7 , on the outside of the machine. They are connected by a short shaft running through the side A of the machine. When the foot-lever s is lowered, the eccentric s^8 may be turned down by means of the crank s^7 , and it will then force the rod s^6 down and hold the lever s down. The spring 101 around rod s^6 , and fastened to it at flange 103 and to frame A at flange 104, keeps the rod tight against the cam s^8 . Spring 102, attached to foot-lever s at 106 and to frame A at 105, raises the foot-lever s when downward pressure is removed.

The method of operating the machine is as follows: The paper is placed on the table A'

against guide C^4 and guide l^2 . The shaft of the paste-roller now descending strikes the projection l^8 , Figs. 25, and 26, and thereby forces the guide l^2 from beneath the roller, as previously described, and the shaft of the paste-roller rests in the sockets 127, Fig. 4, which are for the purpose of preventing the paste-roller being thrown out of line when pinion j is moved by spur M . The teeth of pinion j mesh in the notches of gear M . (The manner of always obtaining this result will be shown hereinafter.) The bar S , Fig. 1, having been forced forward by means of mechanism previously described, forces lower portion of device K forward and portion M backward. This action imparts a rotary motion to the paste-roller, and it draws the paper around it on the side toward the paste devices.

It may be here remarked that there are some advantages in having the paper roll around the paste-roller: First, it saves the operator putting the paper so far into the machine as would be necessary if the paper did not wrap around the roller; second, if it did not wrap around the roller, the roller would have to work backward and forward, and the machine would consequently have to be larger than with this arrangement; third, it avoids devices for preventing the paper wrapping around the roller. The device K is now reversed by its moving mechanism and the paper unrolled from the paste-roller. As the paper is unrolling the folding-knife B is allowed by cam 14 to descend, and it forces the paper through the slot 55, Fig. 3, and between roller 28^a on the one side and twines Z^1 and cloth Z on the other side, Fig. 4, which pass under roller 28^a . This completes the first folding. The paper is now carried on twines Z^1 , which are above cloth Z , over roller 60, and under roller 63.

By passing over roller 60 twines Z^1 are raised above cloth Z immediately after leaving roller 28^a , and thereby prevent any tendency of the paper to stick to cloth Z . The forward edge of the paper is turned down after passing over roller 60 by twines 65, which turn in the opposite direction from roller 60. The twines Z^1 pass through slots 125 in the front edge of the rear portion of the table A' under second folding-knife, and thereby cause the paper to slip under the second folding-knife. Roller 63 again aids in putting the paper in position by overcoming the friction of the paper with the plate after it leaves the twines. When it has reached the position determined by the guides b the second folding-knife B^1 descends, folds the paper a second time, and forces it between the cloth Z^2 and twines Z^1 , which pass together around the drying-cylinder T .

In the passage around the cylinder T the paste is thoroughly dried. After leaving the cylinder T the cloth Z^2 and twines Z^1 pass over roller 19, beyond which point they separate. The cloth Z^2 being the lower one, the paper remains on it, and is thus carried

along until it reaches roller 20, when it drops off onto the table V, or the papers which have already dropped thereon.

Having the twines Z¹ between the paper and cylinder T prevents leaving the paper sticking to the cylinder, as in some cases might happen. The presser V⁵ now presses down on it.

When there are no papers on table V it is screwed up as far as it will go by means of the crank V⁴. When the presser V⁵ meets with but little resistance, the pitman W¹, (see Fig. 16,) by means of the connecting-spring W⁷, draws the arm X rearward, and consequently depresses the arm X¹, Figs. 16 and 19, which, impinging against pin X⁶ projecting from side of lever W⁴, depresses the rear end of lever W⁴ and elevates the forward end, which, impinging against the pin 91, projecting from the pallet W³, raises the pallet up, and holds it up until the pallet is drawn backward, and the pin 92 rests on the top of pallet-arrester X³, as shown in Fig. 17, thus preventing the pallet from moving the ratchet X², and consequently no motion is given to the shaft X⁴, and, further, no motion is imparted to the screw U or table V.

As long as the presser V⁵ meets with but little resistance the lever W⁴ will be forced up in the manner described, and will thus prevent the pallet from falling into the ratchet when the pin 92 is forced beyond the edge of the pallet-arrester X³, and the lever holds the pallet up until the pin 92 passes back over the pallet-arrester X³, as previously described; but when such a quantity of papers has collected that the presser V⁵ meets with sufficient resistance, the arm X is not drawn rearward, but the spring W⁷ stretches, and the arm X¹ is not depressed; consequently the pin X⁶ is not lowered and the lever W⁴ is not raised upward to catch the pin 91, as the pin 92 passes over the edge of the pallet-arrester X³; consequently the pallet drops into the ratchet, and moves it forward until the table V has been lowered to such an extent that the presser V⁵ meets with so slight resistance that the pallet is again lifted from the ratchet, as previously described.

The nearer the weight W⁵ is brought to shaft X⁵ the greater will be the resistance required to prevent the pallet from moving the ratchet; hence the papers will be pressed more tightly, and the amount of pressure on the papers can be regulated by the sliding weight W⁵. Instead of weight W⁵, a spring or other elastic medium whose tension can be regulated may be used. Moreover, by the adjustment of the arms on the shaft X⁵ the same result will be obtained.

When the shaft 3 raises the arms 49, and with them the roller F, and forces the shaft F' of roller F into the open sockets g, (see Fig. 23,) the device G turns on shaft of paste-feed roller, and the teeth of pinion k, Figs. 12 and 3, mesh with the teeth of spur 69, and

the teeth of pinion k⁴ on the other end of the shaft mesh with teeth of the arm Q. (See Fig. 4.) The roller E is turned by the cord over pulley 70 in such a direction that the top of roller E turns from the rear toward the front of the machine, and the pinion k, meshing with gear 69, turns the roller F in the opposite direction from that in which roller E is turning; and the teeth of pinion k⁴, meshing with teeth of arm Q, would turn the roller F in the same direction as roller E were it not for the fact that pinion k⁴ is loose on shaft F, and the ratchet k⁵ allows said pinion k⁴ to turn in this said same direction as roller E without affecting roller F. Now, when the motion of shaft 3 is reversed, and the arms 49 start downward, the motion of roller F would be reversed; but the pinion k⁴, now turning in the direction opposite to which it first turned, faces the ratchet k⁵, and consequently the roller F, in the same direction as itself. The ratchet k⁴ is so constructed as to allow this motion in a manner similar to the action of ratchet k⁵, previously described. Hence, the roller F always turns in the same direction when it is receiving paste. Moreover, when it descends, it turns a little faster than the roller E in order to shake off the little roll of paste which forms in front of the two rollers. It may be here remarked that roller F does not touch roller E, and its distance from roller E is regulated by the device shown in Fig. 23.

The machine is regulated (the operation will be described hereinafter) to paste the paper one-fourth ($\frac{1}{4}$) of its length. The paper is then folded, and the two ends pressed together by passing between roller 28^a on the one side, and cloth Z and twine Z¹ on the other side. The second folding-knife again folds the paper in the center, thus bringing the second fold along the edge of the pasted portion.

As the paper passes under and around the paste-roller there is a little roll of paste between the two, and driven before the paste-roller. To avoid leaving this ridge of paste on the paper, the tripper m², Fig. 6, comes into action. As a part of tripper m² is raised above the line 100, it acts as a cam and lifts lever, b⁸, and consequently lever J, which forces bolt b¹ against pin b⁵, thereby turning shaft 3 slightly, and this motion raises the paste-roller F away sufficiently to lift it over the little ridge of paste.

As soon as device K is rotated so far as to pass tripper m² from under lever b⁸ the motion is reversed; and as soon as the lever b⁸ is released from the tripper m² the spring b⁹ forces it over the space between the two trippers. The reverse motion of device K forces tripper n¹ through the slot. This reverse motion also turns the roller F in the opposite direction, thus unrolling the paper from it. The effect of these operations is to raise the roller from the edge of the film of paste where it forms a rib, and then move the paper so that the roller,

after being reversed, strikes the rib and carries the paste back, spreading it on the surface on which it lay before.

As the paper is being unrolled from the paste-roller, the first folding-knife B descends and forces the paper through the slot 55, where it is grasped and drawn down by the roller 28^a on the one side and the twines Z¹ and cloth Z on the other. It may be remarked that the paper is not forced by the knife B through the slot 55 quite as rapidly as it is unrolled from the roller F. At the moment the edge of the paper is about leaving the paste-roller it is grasped by the roller 28^a and twines Z¹ and cloth Z, and jerked away from the paste-roller.

Before the tripper *m*¹ passes entirely from under the lever *b*⁸ the paste-roller F is raised by the proper devices previously explained, and by this means the roller 78 is kept perfectly free from paste.

The device represented in detail on Sheet 5 is for the purpose of directing the teeth of the pinion *j* on shaft F' into the interdental spaces on spur M. As the pinion descends the spur-rod L is above the edge of device K; and, from the shape of the teeth of pinion *i* and the end of rod L, rod L must necessarily force pinion *i* around until the top of rod L is at the apex of the notch between two teeth, and this no matter what part of the tooth strikes rod L, as seen in Fig. 5. By this time device K has been forced just far enough on its rearward motion to allow the arm *n*¹ of lever N to escape beyond the end *o*¹ of trigger *o*, and consequently there is no obstacle to prevent the descent of rod L, which is brought down by its own weight, aided by spring 73, or forced down by pinion *i*. By this arrangement the teeth of pinion *j* are always compelled to fall into the interdental spaces on the spur M. The device K continues this rearward motion until it takes a position about as shown in Fig. 6 and the rod L is as shown in Fig. 6. After tripper *m*² has passed through slot in lever *b*⁸ the motion of device K is reversed, and as it comes back the arm *n*¹ of lever N strikes on arm *o*¹ of device *o*, and forces it down, as shown in Fig. 9, until it passes the edge of arm *o*¹, when the spring *o*⁵, Fig. 11, brings trigger *o* back to its normal position—that is, with arm *o*² pressing against pin *o*³; and this last motion, combined with the continued motion of device K, forces the rod L up in the position shown in Fig. 5. The device is now held stationary while the roller F rises, receives paste, and as it descends pinion *i* on shaft of said roller strikes rod L, when the motions described are repeated. A spring keeps the roller 8 close against the side of the cam 28, in order to avoid any irregularities in the motion of device K which would arise from any play between side of cam 28 and roller 8. The spring Y around axis 2 is provided for a similar purpose with respect to the arm *b*^{1*}.

The machine is constructed throughout in

such a manner that it can be regulated, whenever necessary, so that papers of different sizes may be folded. First, the middle portion of the top A', with the pieces attached thereto, may be placed nearer to or farther from the slot 55 by means of suitable regulating devices. The paste-roller is to paste one-fourth the length of the paper, and consequently the amount of its revolution must be regulated to the extent required. This is accomplished by raising or lowering the lever S in the slot *p*, and thereby changing the length of the arc of revolution of the spur M; also, the distance of the guide *l*² from slot 55 must be fixed. This is done by the adjustment first described, of moving the middle part of the top A' of the table.

These two adjustments of moving top A' and changing arc of spur M may throw the spur-rod L out of the line of motion of pinion *i*. This difficulty, however, is met by means of the regulation of length of rod S, or rather of distance between pivot 7 and forward end of rod S, permitted by slot 111 in rod S. These adjustments will require a change of the nut *r*⁸ on rod *r*, so that the roller F will not be raised too soon or too late. When the arc described by device K is changed, the position of the trippers *m*¹ and *m*² must be changed by means of the devices shown in Fig. 10, and previously described. In order to secure the second folding of the paper in the middle of the sheet, the guides *b* *o*, Fig. 3, must be moved forward or backward sufficiently to produce the effect desired.

The position of table C⁴ is regulated by the set-screws 107. (Shown in Figs. 2 and 3.) The amount of pressure of the paste-roller on the paper can be regulated to a certain extent—that is, the weight of the roller and attachments may rest upon the paper, or extra pressure added by means of the spring *r*⁵. When there is a small space between the sleeve *r*⁴ and thimble *r*¹¹, when the paste-roller is on the paper, there will be no pressure upon the paper except that caused by the weight of the roller and its attachments. If, now, by means of the adjusting-nuts *r*⁶, the rod *r*⁹ is forced forward until the thimble *r*¹¹ presses the sleeve *r*⁴ and is forced backward along the rod *r*⁹, the spring *r*⁵ will exert a downward pressure upon the roller through the intervening mechanism, and the amount of this pressure can be regulated by the nut *r*¹².

What I claim as new, and desire to secure by Letters Patent, is—

1. The combination, in the roller E, of the shell, diaphragms 112, disks 114, hub 113, and nut 115, all arranged within the shell, substantially as set forth, for the purpose specified.

2. The combination, with the pasting-roller, of the pivoted rack-arm Q and spur-gear *k*⁴, ratchet *k*⁵, and pawl *k*⁶, for the purpose of causing the roller to free itself from the ridge of paste.

3. The combination, with the pasting-roller,

F, carried by vibrating arms and feed-roller E, of the device for adjusting the distance between said rollers, and consisting of the arm G, socket *g*, and adjustable box *g*⁷, substantially as set forth.

4. The device for adjusting the folding-plate B upon the termination *a* of arm *b*, consisting of the set-screws *a*¹ *a*², bolt *a*³, plate B³, and knife B, and arm *b*, combined together, substantially as described.

5. In combination with spur-rod L, the arms *n* *n*¹ and trigger *o*, stop *o*³, springs *o*⁵, and lever K, substantially as and for the purposes set forth.

6. The combination of devices for causing the teeth of spur-wheel *j* to mesh with the teeth of spur M, and consisting of wheel *i*, spur-rod L, spring 73, arms *n* *n*¹, trigger *o*, stop *o*³, spring *o*⁵, and lever K, arranged substantially as described.

7. The combination of pinions *i* and *j*, segment-gear M, and spur L, substantially as and for the purposes set forth.

8. The combination of lever K, provided with slot *p*, pitman S, provided with slot 111, pivot 7, arm P, provided with slot *o*⁷, bolt *h*², and nut *h*³, substantially as and for the purposes specified.

9. The combination of the pasting-roller and devices, substantially as described, and as shown in Figs. 5, 6, 9, or their equivalents, for raising and lowering the roller and for turning it in different directions, as and for the purpose specified.

10. The tripper-cams *m*² *m*¹, in combination with the lever *b*⁸, springs *b*⁹, bolt *b*³, extension *b*⁴, bolt *b*⁶, lever J, shaft 3, set-screw *b*¹, pin *b*⁵, substantially as and for the purposes set forth.

11. The tripper-cams *m*² *m*¹, in combination with the lever *b*⁸, springs *b*⁹, bolt *b*³, extension *b*⁴, bolt *b*⁶, lever J, shaft 3, set-screw *b*¹, pin *b*⁵, arms 49, springs 68, and roller F, substantially as and for the purposes specified.

12. The combination of the pasting-roller, folding-knife, and devices, substantially as described, and shown in Figs. 5, 6, 9, or their equivalents, whereby the paper is wound up on the roller thus pasted, and then folded by the knife, substantially as specified.

13. The combination of the roller F, arms 49, springs 68, the tripper-cam *m*², lever *b*⁸, springs *b*⁹, bolt *b*³, extension *b*⁴, bolt *b*⁶, lever J, shaft 3, set-screw *b*¹, pin *b*⁵, substantially as and for the purposes specified.

14. In combination with pasting-roller F, the scrapers *e e*, adjustable on rod *e*³, for the purposes set forth.

15. In combination with roller 78, the holder 81, bolt 82, bolt 83, nut 84, and table A', for the purposes set forth.

16. The combination of pitman W¹, lever W², shaft X⁵, provided with presser V⁵, arm W⁶, weight W⁵, arm X, spring W⁷, lever X¹, pin X⁶, lever W⁴, pallet W³, pins 91 and 92, shaft X⁴, ratchet X², pallet-arrester X³, standard W⁸, beveled gears 88 V³, screw U, table V V².

17. The combination of pitman W¹, lever W², shaft X⁴, presser V⁵, ratchet X², pallet W³, pin 92, pin 91, pallet-arrester X³, standard W⁸, shaft X⁵, arms X, X¹, and W⁶, weight W⁵, lever W⁴, provided with pin X⁶, spring W⁷, substantially as set forth.

18. The combination, with the screw-shaft, nut, and gears of the adjustable arm X, of shaft X⁴, spring W⁷, pitman W¹, lever W², pawl and ratchet-wheel, substantially as and for the purposes set forth.

19. The devices for retracting the guide on the descent of the roller, consisting of the combination of roller F, projection *l*⁸, arm *l*⁴, lever *l*³, spring *l*⁵, guide-rod *l*, provided with guide-piece *l*², substantially as and for the purposes specified.

20. The shaft 3, its arms 49 *r*³, roller F, rock-sleeve *r*¹, sleeve *r a*, and set-screw *r*⁸, with rod *r* and lever R, all combined, substantially as and for the purposes specified.

21. The slotted rod *r*⁹, provided with spring *r*⁵, thimble *r*¹¹, and nut *r*¹², and nuts *r*⁶, and combined with rock-sleeve *r*⁴, rocking on lever *r*³, and rock-sleeve *r*¹⁰, attached to fixed standard *r*⁷, substantially as and for the purposes set forth.

22. The devices, consisting of the rollers 63 and 64, provided with tapes 65, and with the slotted arms 66 and set-nuts, in combination with twines Z¹ and folding-knife B¹, substantially as and for the purposes specified.

23. The combination of foot-lever *s*, spring 102, rod *s*², lever *s*⁴, lever 72, pulleys 35 and 36, cord 71, spring 87, substantially as and for the purposes set forth.

Cincinnati, May 12, 1877.

EDWIN CRAWLEY.

Witnesses:

C. WALTON, Jr.,

W. S. CHRISTOPHER.