

W. HARNAH.  
Machine for Eyeleting Umbrella Cases.

No. 202,168.

Patented April 9, 1878.

*Fig. 1.*

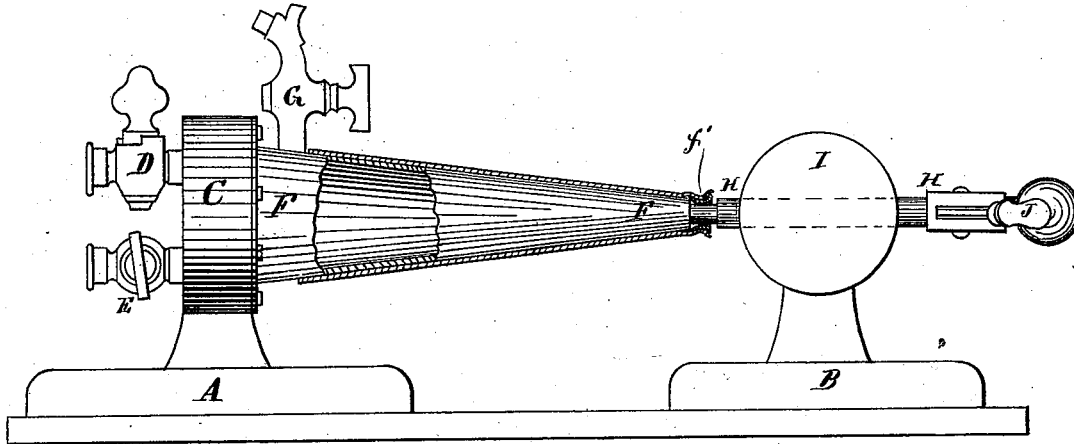

*Fig. 2.*

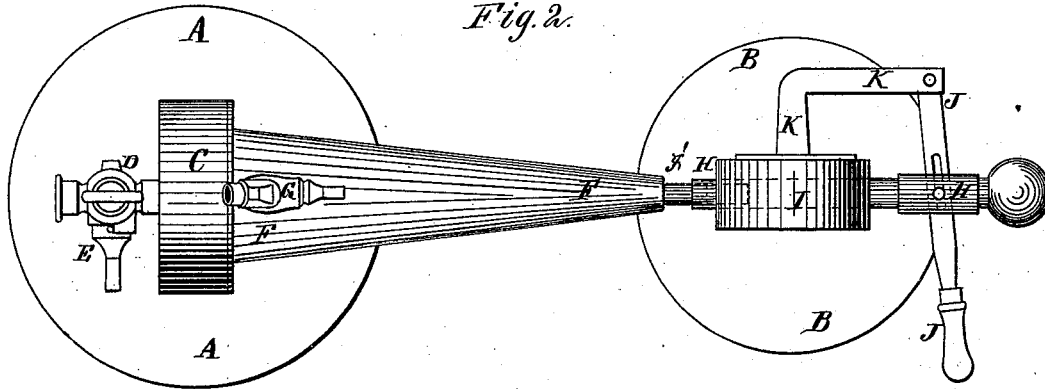

WITNESSES:

*Henry W. Miller*  
*C. Sedgwick*

INVENTOR:

*W. Harnah*  
BY *Munnell*

ATTORNEYS.

# UNITED STATES PATENT OFFICE.

WILLIAM HARNAH, OF NEW YORK, N. Y.

## IMPROVEMENT IN MACHINES FOR EYELETING UMBRELLA-CASES.

Specification forming part of Letters Patent No. **202,168**, dated April 9, 1878; application filed February 25, 1878.

*To all whom it may concern:*

Be it known that I, WILLIAM HARNAH, of the city, county, and State of New York, have invented a new and useful Improvement in Machines for Turning and Eyeletting Cases, of which the following is a specification:

Figure 1 is a side view of my improved machine, part being broken away to show the construction. Fig. 2 is a top view of the same.

Similar letters of reference indicate corresponding parts.

The object of this invention is to furnish an improved machine for turning and eyeletting cases for umbrellas, whips, canes, fishing-rods, &c., which shall be simple in construction and convenient in use, enabling the cases to be easily and quickly turned and supplied with eyelets.

The invention consists in the vessel, the hollow cone having a round tenon formed upon its forward end, and provided with the inlet, outlet, and air faucets, the hollow follower and its stand, lever, and supporting-arm, in combination with each other, to adapt the machine for use for turning and eyeletting cases, as herein-after fully described.

A and B are the bases of the two parts of the machine, which are made of such a size as to give the said parts a firm and stable support. To the base A is attached a hollow stand, C, which is made in the form of a short section of a cylinder, and which is supplied in the upper part of its outer side with a faucet, D, through which warm water is introduced, and in the lower part of said outer side with a faucet, E, through which the water is drawn off when desired.

The forward side of the stand C is open, and to it is attached the base of a hollow cone, F, which is made of the length, size, and taper of the cases to be turned and eyeleted. The hollow cone F is provided upon the upper side of its base with a faucet, G, to serve as a vent, to allow the air to escape while the vessels C F are being

filled with warm water. Upon the forward end of the hollow cone F is formed a round tenon, *f'*, to receive the eyelet, and which fits into the cavity of the hollow follower H. The follower H slides in a stand, I, attached to the base B, and its forward part is slotted to receive the lever J, which is pivoted to it by a pin. The lever J is slotted longitudinally to receive the pivoting-pin, so that it may adjust itself as the said follower slides back and forth. The end of the lever J is pivoted to a bent arm, K, attached to the stand I.

In using the machine the follower H is drawn back, and the case, wrong side out, as it was sewed, is slipped upon the cone F. The eyelet is then slipped upon the tenon *f'*, the end of the case is drawn over its groove and tied, and the follower H is moved forward, closing the eyelet between its end and the shoulder of the tenon *f'*. The upper end of the case is then turned back, and is drawn off, which turns it. The warmth of the cone F softens the material of which the cases are made, and makes them very pliable, so that they may be readily turned.

I am aware of the existence of a machine for fixing metallic rings to umbrella-cases, consisting of an anvil, spring-puppet, holding heating-post, hammer, water-tank, boiler, and circulating-pipe.

Having thus described my invention, I claim as new and desire to secure by Letters Patent—

The stand C, the hollow cone F, having a round tenon formed upon its forward end, and provided with the inlet, outlet, and air faucets D E G, the hollow follower H, and its stand I, lever J, and supporting-arm K, in combination with each other, to adapt the machine for use for turning and eyeletting cases, substantially as herein shown and described.

WILLIAM HARNAH.

Witnesses:

JAMES T. GRAHAM,  
C. SEDGWICK.