

J. OSTERGARD.

Device for Holding and Counting Coin.

No. 202,188.

Patented April 9, 1878.

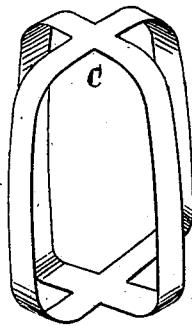
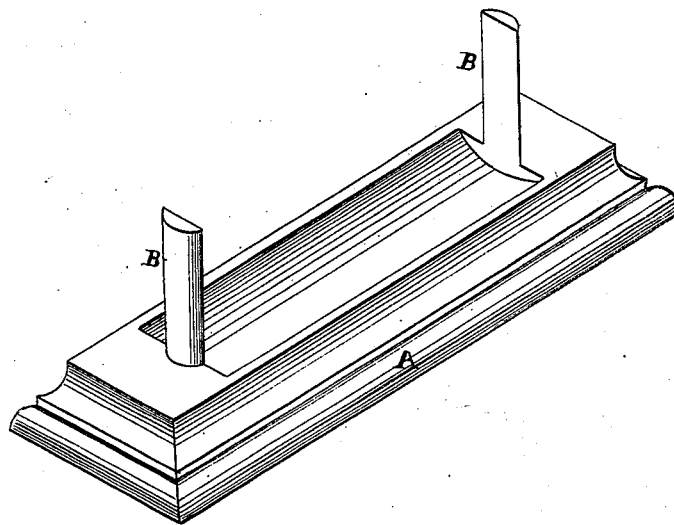

Witnesses

*Geo. H. Strong.*  
*Ans. L. Borne*

Inventor

*James Ostergard*  
*By his atty*  
*Dewey & C*

# UNITED STATES PATENT OFFICE.

JAMES OSTERGARD, OF CHERRY CREEK, NEVADA.

## IMPROVEMENT IN DEVICES FOR HOLDING AND COUNTING COIN.

Specification forming part of Letters Patent No. **202,188**, dated April 9, 1878; application filed March 2, 1878.

*To all whom it may concern:*

Be it known that I, JAMES OSTERGARD, of Cherry Creek, county of White Pine, and State of Nevada, have invented a Device for Counting and Forming Coin Packages; and I do hereby declare the following to be a full, clear, and exact description thereof, reference being had to the accompanying drawing.

My invention relates to a novel device for counting a number of coins and forming them into a roll, so that they can be conveniently covered or inclosed by any convenient form of coin-holders to make a single package.

It consists of a metallic base having vertical standards, between which a certain number of coins are placed to form a package.

Referring to the accompanying drawing, A is a base, of any suitable metal, having parallel horns or standards B B projecting vertically near each end. Between these standards the top of the said base is hollowed out to any convenient portion of a circle.

It will be generally found suitable to make this hollow conform to about one-fourth or one-fifth of the circumference of the coin package to be rolled or put up.

My invention is very convenient, especially where a large amount of coin is to be counted and formed into packages. As it can be done

very rapidly and accurately with this contrivance, it is especially adapted to be used in combination with the invention of J. O. Pattee and A. B. Goldstein, known as the "elastic coin-holder," and shown at C.

The operation will be as follows: The required amount of coin having been placed between the standards B B of my device, the elastic coin-holder is placed around the said standards and roll of coin at the same time; then lift the roll thus inclosed. This action will disengage the elastic coin-holder from the horns B B and the package of coin at the same time, thus completing the package.

Having thus described my invention, what I claim as new, and desire to secure by Letters Patent, is—

The device consisting of the concave base A with the standards B B, having a space between them to receive a specified quantity of coins, said standards being fitted to receive and apply the holder C, substantially as herein described.

In witness whereof I have hereunto set my hand and seal.

JAMES OSTERGARD. [L. S.]

Witnesses:

A. B. GOLDSTEIN,  
O. H. GUY.