

J. R. REED.
 Steam-Radiator.

No. 202,192.

Patented April 9, 1878.

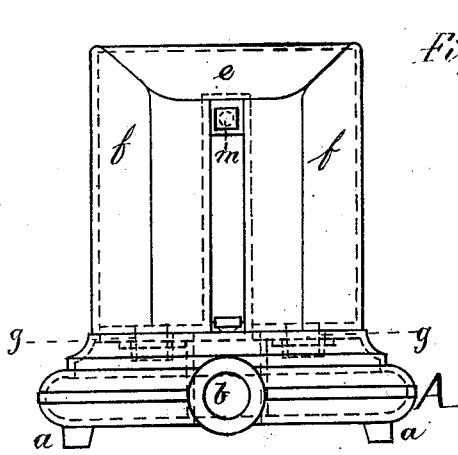

Fig. 1.

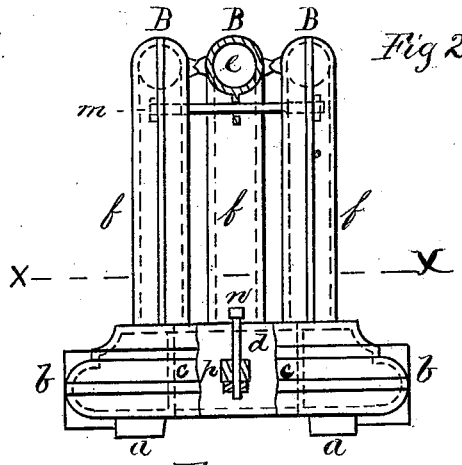

Fig. 2.

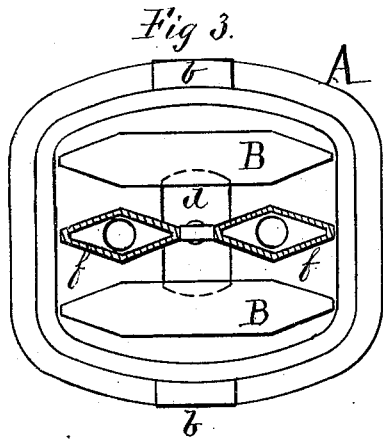

Fig. 3.

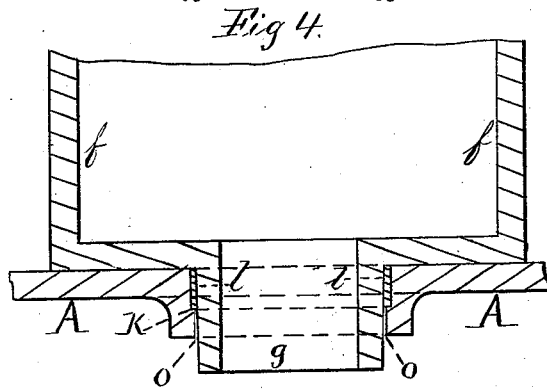

Fig. 4.

Witnesses
 James M. Hicks
 William S. Jenkins

Inventor
 John R. Reed
 by his atty
 J. M. Hicks

UNITED STATES PATENT OFFICE.

JOHN R. REED, OF WESTFIELD, MASSACHUSETTS.

IMPROVEMENT IN STEAM-RADIATORS.

Specification forming part of Letters Patent No. **202,192**, dated April 9, 1878; application filed December 27, 1877.

To all whom it may concern:

Be it known that I, JOHN R. REED, of Westfield, State of Massachusetts, have invented Improvements in Steam-Radiators, for warming buildings; and I hereby declare that the following is a full, clear, and exact description and specification of the same, taken in connection with the accompanying drawings, making part thereof.

My invention appertains to radiators made with circulating-divisions, connected by joints to a base provided with induction and education openings, so that steam from a boiler may enter, circulate through the divisions, and condense, the heat thus set free being radiated into the surrounding air through their exterior surfaces.

My invention consists in certain new combinations of mechanism, specifically set forth at the end of this schedule, by means of which I am able to produce steam-radiators more durable, more cheaply constructed, and less liable to leak than those now in use.

In order that persons skilled in the art may understand, make, and use my improvements, I will proceed to describe, by aid of the drawings, the manner in which I have embodied them.

Figure 1 represents a vertical end view of said radiator complete. Fig. 2 represents a vertical side view of same, partly in section. Fig. 3 represents a top view of said radiator, having three circulating-divisions alike, the center one being shown in section on a horizontal line, *x x*, Fig. 2. Fig. 4 is an enlarged vertical section through the center of one of the legs of the circulating-divisions, showing the new means of connection between the legs and the reservoir-base.

A is the reservoir-base, mounted on feet *a a*. It is hollow, and is provided with inlet and outlet openings *b b*. Its upper face is perforated by six openings, *o o*, communicating with the interior of said reservoir. It is also provided with the inner walls *c c*, surrounding the opening *d*, which extends entirely through from the top to the bottom, leaving the interior steam-space in one continuous channel.

B B B are the circulating-divisions, the legs *f f* of each being connected at the top by a horizontal pipe, *e*, forming one piece. They

are hollow, to permit a continuous circulation or flow of steam through them. These legs are partially closed at the bottom, but tubes *g* extend from it downward, tapered on their exterior surfaces, their diameter being greatest near the bottom of the legs, where the legs and the tube are united. Through these tubes the steam flows to and from the reservoir-base. The holes *o o* in the reservoir-base are made larger than the outer diameter of the said tubes, and are provided with shoulders K K, forming ring-shaped recesses, into which are placed soft-metal rings *l l*, large enough in diameter to nearly fill the recess, but with an internal diameter smaller than the exterior diameter of the upper portions of the tubes *g* before they are put into the rings and the rings into the recesses.

The holes *o o* in the base A may be cast on chills, and the tubes *g* are cast in chills, so that their tapering surfaces are hard and smooth. This latter is an important feature of my radiator.

The rings of soft metal having been placed in the holes *o o*, the ends of the tubes on the divisions B are inserted in the rings, and the whole placed under a powerful press, when the tubes are forced into the rings until the bottom of the divisions B are in contact with the upper part of the base A, or nearly so. The taper of the tubes spreads the rings into the recesses, makes a tight fit between the tubes and the rings, as well as between the rings and the recesses, and renders the joints firm and steam-tight.

The holes *b b* are tapped out to receive the steam-pipes, and a bolt, *m*, is put through the several divisions, as shown, to hold them together.

A bolt, *n*, and a bar, *p*, are shown holding the center division to the reservoir-base. They are not necessary under ordinary circumstances, but may be useful to guard against the accidental loosening of the joints by severe blows.

The operation of the radiator is as follows: Steam is admitted through a pipe screwed in opening *b* into the interior of the reservoir-base A. It then flows up the legs of the circulating-divisions B B B on one side or the other, and down the legs on the other side,

condensing partially, as it flows forward, the water of condensation with any uncondensed steam; then flows out from the pipe in the hole *b* on the side opposite the inlet-pipe *b*.

The heat given off by the condensation is thrown into the air surrounding the radiator, as is well understood.

I do not claim, broadly, the method of uniting two parts by forcing tubes into rings held in recesses to make tight joints, as shown in W. Smith's patent of September 15, 1874, or in E. G. Blakeslee's patent of July 16, 1867, each for improved clamps and couplings.

Having now fully described my invention in the form in which it was embodied by me, what I claim, and desire to secure by Letters Patent, is—

1. The combination, substantially as herebefore set forth, in a steam-radiator, of the reservoir-base, provided with recessed holes

in its upper plate, and double-legged circulating-divisions, cast in one piece, having tapering end tubes, with soft-metal packing-rings to seal the joints, all constructed and arranged to operate substantially in the manner described.

2. The combination, substantially as described, in a steam-radiator, of a reservoir-base having two or more recesses in its upper plate, adapted to support and hold the packing-rings, with one or more circulating-divisions, having tapering chilled end tubes cast in one piece with said divisions, and the soft-metal packing-rings for uniting said parts, as set forth.

JOHN RICHARD REED.

Witnesses:

HENRY M. SMITH,
MOSES P. BRECKENRIDGE.