

S. KEELER.
Seal-Fastening.

No. 202,267.

Patented April 9, 1878.

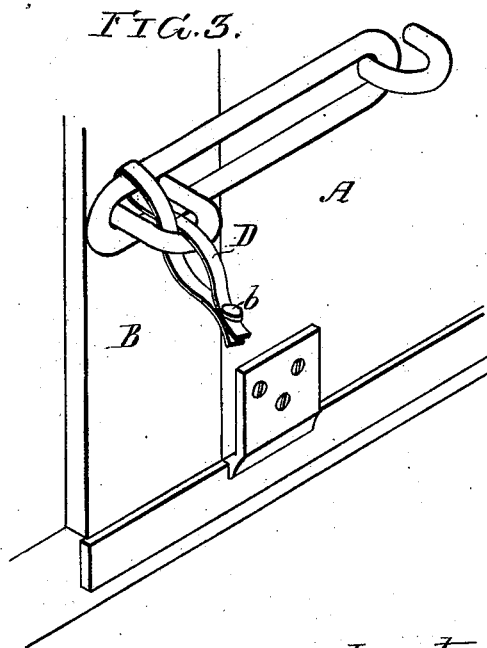
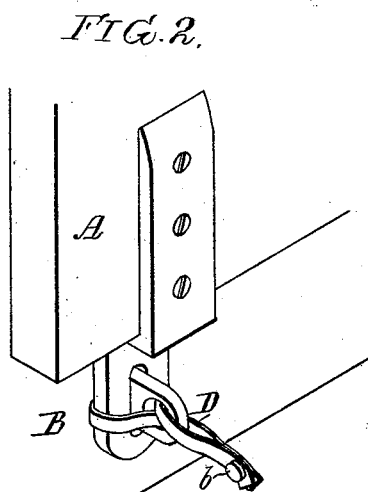
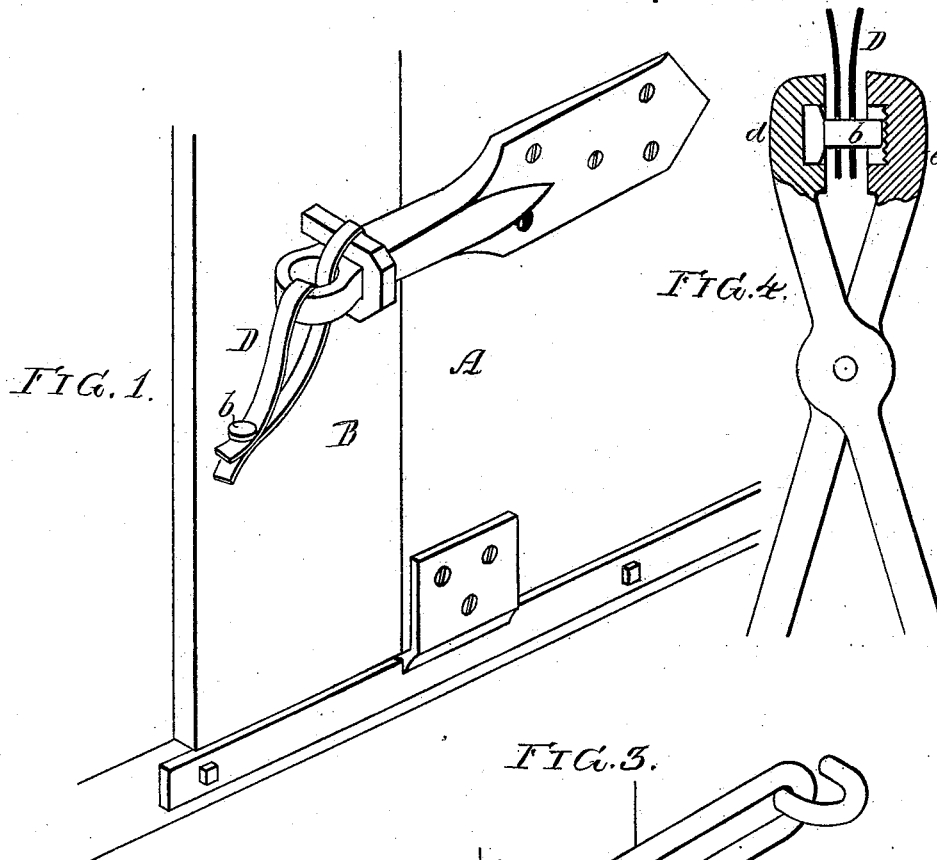

Witnesses
Henry Housman Jr.
Harry Smith

Inventor,
Sanford Keeler
by his Attorneys
Howson and Son

UNITED STATES PATENT OFFICE.

SANFORD KEELER, OF EAST SAGINAW, MICHIGAN, ASSIGNOR OF ONE-HALF HIS RIGHT TO W. J. WATSON, OF CHICAGO, ILLINOIS.

IMPROVEMENT IN SEAL-FASTENINGS.

Specification forming part of Letters Patent No. **202,267**, dated April 9, 1878; application filed January 26, 1878.

To all whom it may concern:

Be it known that I, SANFORD KEELER, of East Saginaw, Saginaw county, Michigan, have invented a new and useful Improvement in Seal-Fastenings for Doors, of which the following is a specification:

The object of my invention is to provide a simple, cheap, and effective seal for application to the fastenings of the doors of cars or other structures—an object which I attain in the following manner, reference being had to the accompanying drawing, in which—

Figures 1, 2, and 3 are perspective views of my improved seal applied to different forms of car-door fastenings; and Fig. 4, a view illustrating the method of completing the seal.

A represents part of the door of a car or other structure, and B part of the frame of the door, the latter having a staple, to which is adapted a hasp on the door in the usual manner. To the hasp and staple is adapted, as shown in Figs. 1, 2, and 3, a strip, D, of strong sheet metal, this strip having an opening near each end, so that when the ends of the strip are brought together the stem of a rivet, *b*, may be passed through the openings. This strip of sheet metal is intertwined with both hasp and staple, as shown in the drawing, in order that the fastening may be more secure than ordinary seal-locks of this class. The rivet *b* is made of lead or other soft metal or alloy, so that it may be readily riveted upon the strip, and thereby secure the ends of the same firmly together.

In order to effect the riveting operation I employ a pair of pinchers, as shown in Fig. 3, one of the jaws, *d*, of this pair of pinchers having a recess adapted to the head of the rivet, while the other jaw, *e*, has formed in it a die composed of any letters, numbers, or marks which it may be desired to impress upon the rivet in order to form a seal, the operations of riveting and sealing being thus performed simultaneously.

When the above-described sealing device is used on a car, access to the interior of the car cannot be gained without either removing the rivet *b* or severing the strip D, thus in either case indicating to the authority whose duty it is to examine the seals when and between what stations the car-door has been opened.

I do not desire to claim, broadly, the combination of the sheet-metal strip and soft-metal seal; but

I claim as my invention—

The combination of the hasp and staple, the sheet-metal strip D, arranged to embrace both hasp and staple, and having openings near its opposite ends, and the soft-metal rivet *b*, having a shank adapted to the openings in the strip, all substantially as set forth.

In testimony whereof I have signed my name to this specification in the presence of two subscribing witnesses.

SANFORD KEELER.

Witnesses:

CLARK S. McMILLAN,
EDWIN SAUNDERS.