

H. KELLY,  
Harvester.

No. 202,269.

Patented April 9, 1878.

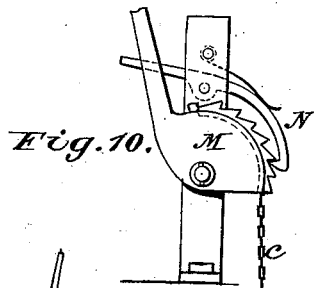

Fig. 10.

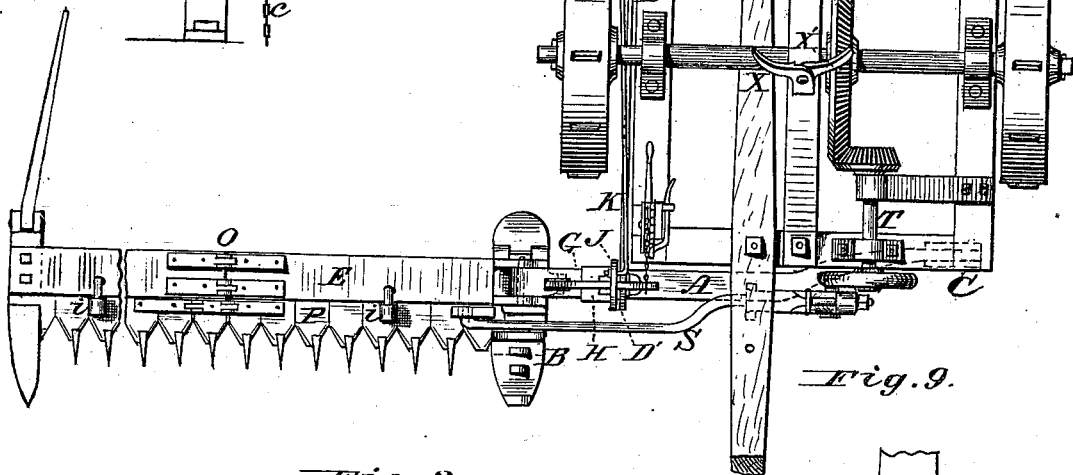

Fig. 9.

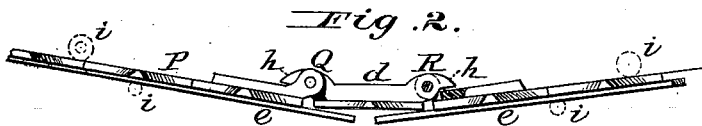

Fig. 2.

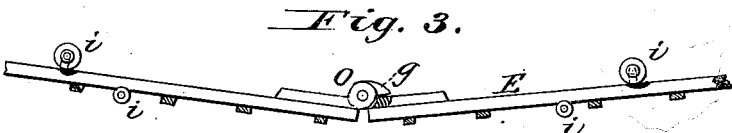

Fig. 3.

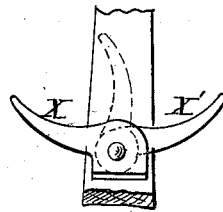

Fig. 7.

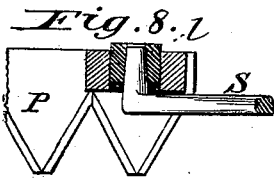

Fig. 8.1

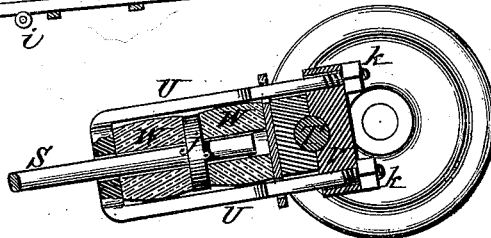

Fig. 6.

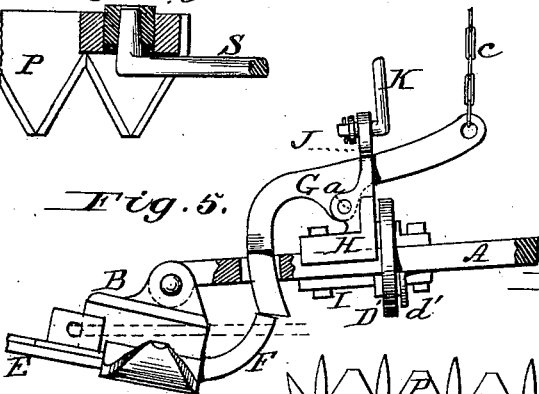

Fig. 5.

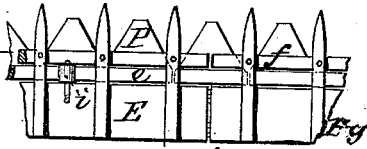
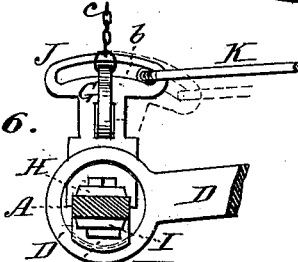

Fig. 4.

Attest:  
H. L. Perrin  
Gloyd Harris

Henry Kelly,  
Inventor.  
Johnson & Johnson  
Attorneys.

# UNITED STATES PATENT OFFICE.

HENRY KELLY, OF OSAGE, IOWA.

## IMPROVEMENT IN HARVESTERS.

Specification forming part of Letters Patent No. **202,269**, dated April 9, 1878; application filed August 14, 1877.

*To all whom it may concern:*

Be it known that I, HENRY KELLY, of Osage, in the county of Mitchell and State of Iowa, have invented certain new and useful Improvements in Mowing-Machines, which improvements are fully set forth in the following specification and accompanying drawings.

In the cutting apparatus I employ a finger-beam, jointed at or near the middle of its length, in connection with a reciprocating cutter having a corresponding hinge or hinges, whereby the finger-beam and the reciprocating cutter may adapt themselves, as to their length, to the inequalities of the ground.

The joint of the cutter is double, and embraces one of the sickle-sections, in order that the cutter and its bar may play back and forth through the fingers, while the finger-beam may have its two sections diverging from a straight line.

The sickle-sections are riveted to the sickle-bar in the usual manner; but the section having the double hinge-joint is riveted to a link connecting the hinges of said double joint, and the sickle-bar is divided at points coincident with these double joints.

A front bar, secured to the guard-fingers, and forming the usual sickle-guide, is separated in line with the beam-joint, and the joint ends of the beam and of the guide-bar allow the divider end of the finger-beam to fall out of line with the heel-end section only a certain distance, and they then abut against each other, and form stops.

The double hinge of the sickle and the hinge of the beam are constructed to form stops to allow only a certain degree of upward flexure of the divider end of the beam, and prevent it from being turned over entirely and breaking the joints.

The fixed and reciprocating parts of the cutting apparatus, adapted for flexure lengthwise, are also adapted for adjustment crosswise, to raise and lower the points of the fingers.

I use a front-cut apparatus hinged at its heel to a coupling-bar, pivoted to the outer front end of the frame. A brace or push bar, pivoted to the rear of the frame, encircles the coupling-bar, near its connection with the

shoe, by means of a ring-termination, the cylindrical bearing for which is formed by an upper and lower casting secured to the coupling-bar, whereby the oscillation of the cutting apparatus is permitted, while obtaining a strong and durable brace-bar connection.

The upper one of the two castings mentioned serves as the pivot-support of a lever, which acts upon a heel-projection of the finger-beam for elevating the outer end of said beam by means of a chain-connection with a ratchet-segment and hand-lever. This casting also has an upper slotted termination, into which plays the front end of a rod, whose rear end is a hand-lever pivoted to the rear inner corner of the frame, and by this slotted connection the points of the guard-fingers are not only elevated, but freedom is allowed for said finger-points to rise when they meet an obstruction, so that the cutting apparatus has a flexible adjustment in every direction to accommodate itself to the surface of the ground.

The jointed finger-beam has upper and lower anti-friction rolls arranged in connection with a reciprocating jointed sickle in such manner as to hold said sickle to its guide, and to render its movements easy.

The sickle pitman-head connection with the crank-shaft consists of a strap, which carries the crank-box, and embraces rubber cushions arranged on opposite sides of a collar on said pitman, whereby the pitman-box holds the springs in place in such manner as to relieve the blow or jarring while the sickle is changing motion and stopping and starting. In this particular construction the pitman passes only into the strap-head through a guide, and is secured by its collar between the springs.

In the accompanying drawings, Figure 1 represents a top view of a mowing-machine embracing my invention; Fig. 2, a front-edge view of the sickle flexed, and showing its double hinge-joint, its divided sickle-bar, and one of the sickle-sections free of said bar at its division-points; Fig. 3, the jointed finger-beam, showing it also flexed; Fig. 4, a detail of the under side of the finger-beam and sickle at the joints thereof; Fig. 5, a detail of the finger-beam and coupling-bar connection, the device for lifting the outer end of the finger-beam, and the brace-ring connection with said

bar; Fig. 6, a detail of the brace-ring connection with the coupling-bar and of the slotted device for oscillating the finger-beam; Fig. 7, a view of the pitman-head crank-connection; Fig. 8, a detail of the pitman-sickle attachment; Fig. 9, the adjustable foot-rest of the driver's seat; and Fig. 10, a detail of the ratchet-connection with the lifting-lever.

The frame carries the tongue and the driver's seat, and the axle turns with the wheels and operates the sickle by the gearing and crank-shaft, as shown in the drawings. These parts may, however, be constructed and arranged in any suitable manner.

The cutting apparatus is carried at the front of the frame by a coupling-bar, A, hinged at the shoe B, and to the outer corner of the frame by a joint, C, admitting of two movements of said bar. A brace-bar, D, pivoted to the rear inner corner of the frame, embraces a cylindrical bearing on the coupling-bar by a ring-termination, D', in a manner to be presently described, and by which said coupling-bar and the finger-beam E may rise and fall and oscillate to raise and lower the points of the fingers.

The shoe and the finger-beam are connected in such manner that a rearward extension, F, of the shoe abuts against the under side of the coupling-bar to limit the descent of the finger-beam, and to receive the action of a pivoted lever, G, by which to elevate the divider end of the finger-beam.

The cylindrical bearing for the ring end D' of the brace-bar is formed by two castings, H I, bolted to the upper and lower sides of the coupling-bar. An extension, J, rises from the upper casting H, and in it is the pivot *a* of the lever G, whose downwardly-curved end abuts upon the upwardly-curved extension F of the shoe. Above the pivot *a* the extension J has a cross-slot, *b*, (shown in Fig. 6,) into which plays the bent end of a rod, K, which extends back, and is jointed to a hand-lever, L, pivoted to the rear inner corner of the frame, and fitted to be moved in a rack-guide rising from the frame, and by this lever the driver raises and lowers the guard-finger points by oscillating the finger-beam. The slot *b* gives freedom for the points of the fingers to rise and to conform to the inequalities of the surface of the ground independent of the hand-lever rack-connection. The brace-bar serves to hold and push the cutting apparatus along, and its ring-termination is held in place against the inner side of the slotted extension and by a collar, *d'*, formed on the under side of the lower part of the cylindrical bearing and the side of the extension J, as shown in Figs. 5 and 6.

The inner end of the pivoted lever G is connected by a chain, *c*, to the lower end of a quadrant-lever, M, pivoted to a standard of the frame, and provided with a rack and spring-dog, N. (Shown in Fig. 10.) By this device the lever G is forced down upon the shoe-extension to elevate the divider end of the finger-

beam and to hold it in such position. As the coupling-bar carries the pivoted lever G, it has a slot (shown in Fig. 5) to allow the acting end of said lever to press upon the shoe-extension and to hold said lever to its action.

The finger-beam has a hinge-joint, O, at or near the middle of its length, and the reciprocating sickle or cutter P has a corresponding hinge-joint formed by a double hinge, Q R, the connecting-bar *d* of which carries one of the sickle-sections, as shown in Fig. 2, while the other sickle-sections are riveted to the usual sickle-bar *e*, Fig. 4, so that the sickle and its bar are separated at points on each side of one of the cutters.

The sickle-bar *e* plays in a guide formed by the front edge of the finger-beam and a bar, *f*, secured to the guard-fingers, and this bar *f*, when made continuous, is separated at a point coincident with the hinge-joint of the finger-beam, as shown in Fig. 4. The abutting ends of the finger-beam joint and of the guide-bar *f* are adapted to allow a certain degree of downward flexure to the outer end of the finger-beam and relieve the hinges of undue strain, while the knuckles of the hinges are provided with stops *g*, to allow of a certain degree of upward flexure to the divider end of the finger-beam, but prevent it from being turned entirely over and breaking the hinges. So, also, are the knuckles of the double sickle-hinge provided with stops *h* for the same purpose. In this way I combine a reciprocating sickle with a finger-beam hinged at or near the middle of its length, and thus obtain the advantage of a flexing cutting apparatus adapted to conform lengthwise to the surface of the ground, while such apparatus has also the capacity to turn or oscillate to elevate and depress the points of its guards.

To the upper and lower sides of the finger-beam I attach small rolls *i*, to hold the cutter in its guide and to reduce its friction. For this purpose they project over the cutter at the top and extend beneath the sickle-bar at the bottom.

The sickle-pitman S is attached to the crank-shaft T by means of a bent strap, U, which carries the crank-box V, and between the box and the inner end of the strap are placed two springs, W, while the pitman passing through a guide in the end of the strap beyond the junction of the springs has a collar, *j*, interposed between said springs, so that the thrusts of the pitman by its collar are upon and are relieved by the springs, thus avoiding the sudden jars in changing centers and in starting and stopping.

The crank-box is held in place by nuts *k* on the open ends of the strap, and the springs are held in place by the box and closed end of the strap, making it very convenient to fit and adjust the box and the springs.

The sickle end of the pitman is made tapering, and a soft brass thimble, *l*, is driven onto it, but not quite up, and as it wears away it is driven up onto the tapered pin of the sickle,

so that it will always fit the sickle-eye and form a close joint.

The standard of the driver's seat has foot-rests X X' one of which, X', is pivoted so as to be turned up out of the way, to allow the cover (not shown) for the gearing to be removed when desired.

The sickle-bar is raised up out of the way in going to and from the field, and when so raised it may be supported and held by a rod from the top of the standard to which the lifting-lever is pivoted.

I claim—

1. A reciprocating sickle or cutter for mowing-machines, having a double hinge at or near the middle of its length, the sickle-section between said hinges being separated from the other sections and secured to the connecting-bar of said double hinge, for the purpose stated.

2. The ring-termination D' of the push-bar D, in combination with the cylindrical bearings H I of the coupling-bar, substantially as described.

3. The combination, with the coupling-bar, of the castings upon the opposite sides, forming a cylindrical bearing, the ring-end brace-bar, and the lever pivoted to and passing through the upper casting, as herein set forth.

4. The combination, with the coupling-bar provided with the castings H I, the cutting

apparatus, and the ring-end brace-bar, of the slotted extension J on the coupling-bar and the hand-lever connecting-rod K, substantially as and for the purpose set forth.

5. The lever G, pivoted upon the coupling-bar, having one end passing through a slot therein, and the other through a slot in the casting H thereon, in combination with the shoe-extension F and the lifting device for lifting the divider end of the finger-beam, as set forth.

6. The ring-termination D' of the brace, in combination with the cylindrical bearing around the coupling-bar, the collar d' of the lower casting, and the upward extension J of the top casting, whereby the ring-termination is held upon its bearing.

7. A mowing-machine having a cutting apparatus hinge-jointed at or near the middle of its length, a coupling-bar hinged to the shoe and to the frame, as described, a slotted extension, J, of the device for oscillating the finger-beam, and a swiveling pitman, whereby the cutting apparatus may adjust itself at either end and oscillate to elevate or depress the points of its guard-fingers.

HENRY KELLY.

Witnesses:

J. E. B. MORGAN,  
CHAS. R. SCHURTZ.