

P. K. O'LALLY.
Bung and Bushing.

No. 202,284.

Patented April 9, 1878.

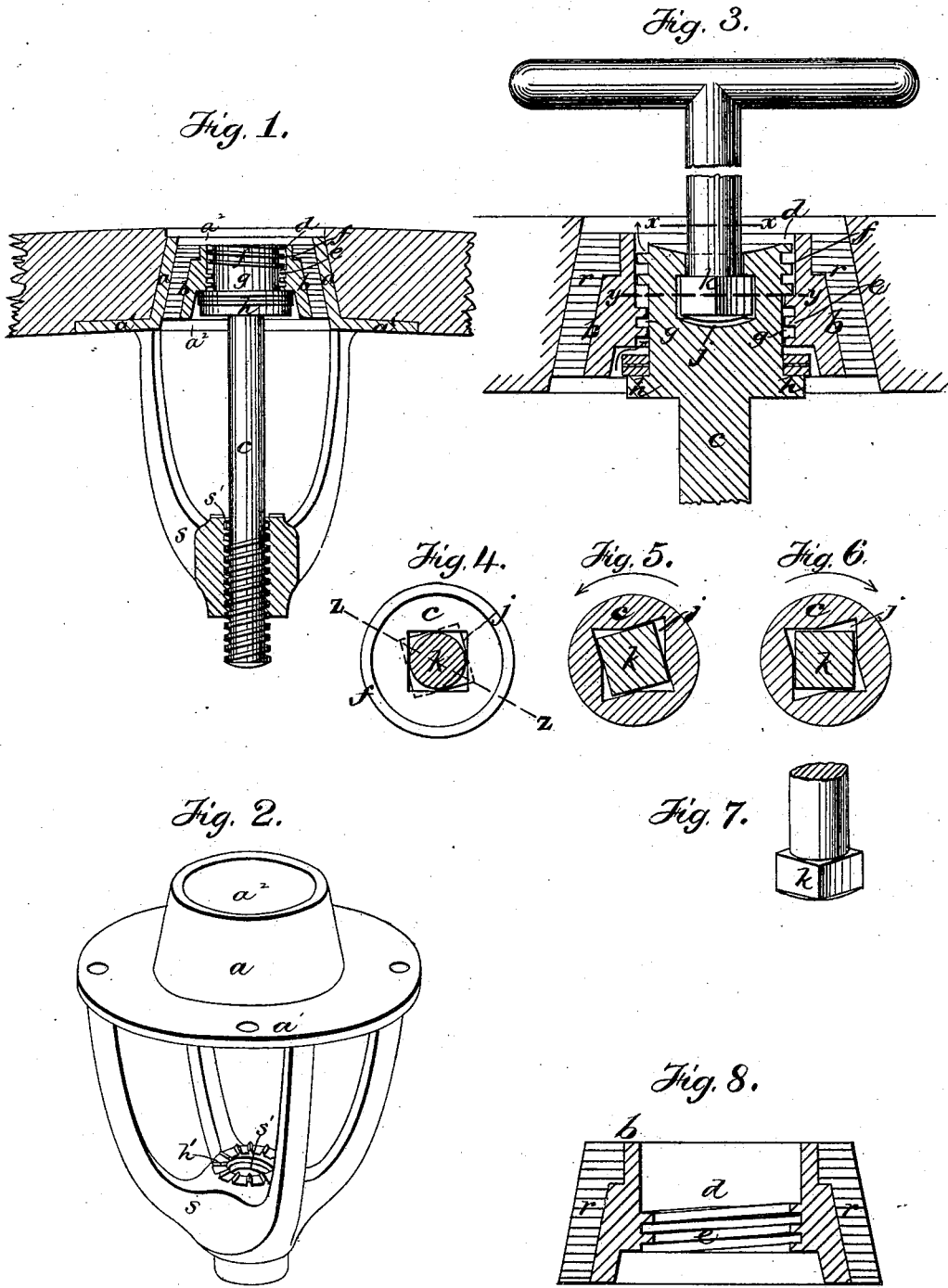

Witnesses.
Geo. W. Pierce,
E. P. Fairchild

Inventor
P. K. O'Lally
by Wright & Brown
Attys

UNITED STATES PATENT OFFICE.

PATRICK K. O'LALLY, OF BOSTON, MASSACHUSETTS.

IMPROVEMENT IN BUNGS AND BUSHINGS.

Specification forming part of Letters Patent No. 202,284, dated April 9, 1878; application filed March 11, 1878.

To all whom it may concern:

Be it known that I, PATRICK K. O'LALLY, of Boston, in the county of Suffolk and State of Massachusetts, have invented certain Improvements in Bungs and Bushings, of which the following is a specification:

This invention relates to bungs and bushings for beer-barrels, or other vessels in which the bung is moved in and out of its seat by a screw; and has for its object to enable the bung to be located within the barrel, so as to stop the bung-hole by being moved outwardly from the inside of the barrel, and vice versa; also, to enable the bung to be held, whether in or out of the hole, in such manner that it can be readily reached and operated; also, to enable the screw which operates the bung to be rotated independently thereof, so that the bung will not be rotated when it is in contact with the hole, and while it is being pressed more firmly into the same; also, to provide means for venting the barrel through the bung without removing the latter from its seat.

To these ends my invention consists in the improvements which I will now proceed to describe and claim.

Of the accompanying drawings, forming a part of this specification, Figure 1 represents a sectional view of a bung and bushing embodying my invention. Fig. 2 represents a perspective view of the bushing detached and without the bung. Fig. 3 represents an enlarged section of the bung on line $z z$, Fig. 4. Fig. 4 represents a section on a line $x x$, Fig. 3, looking down onto the top of the stem of the bung. Figs. 5 and 6 represent sections on line $y y$, Fig. 3, showing the wrench in different positions. Fig. 7 represents a perspective view of the lower end of the wrench. Fig. 8 represents a sectional view of the bung.

Similar letters of reference refer to corresponding parts.

In the drawing, a represents the bushing, which is provided with a flange, a^1 . This flange is adapted to be attached to the interior of a barrel, and is provided with holes for screws or other fastening devices. The lower side of the flange a is preferably curved to follow the sweep or curvature of the vessel in both directions. The bung seat or hole a^2 tapers or decreases in diameter outwardly from

the flange a^1 , so that a similarly-tapered bung can only be fitted into it from the inside of the barrel.

S represents a bridge or spider, which is rigidly attached to the under side of the flange a^1 , and is by preference cast in one piece with the flange and bushing. The bridge or spider is provided with a threaded socket, s' .

b represents the bung, which is tapered to fit the seat or hole a^2 of the bushing, and is arranged to enter the same from the inside of the barrel. I prefer to provide the bung with a removable inclosing-ring or packing, r , of rubber, the body of the bung being preferably of metal, and of a diameter at its larger end less than the diameter of the small end of the hole a^2 , so that the bung can be passed through the hole a^2 before the packing-ring r is applied, the latter being compressed and passed through the hole and applied to the bung inside of the barrel. This arrangement enables the bung and packing to be readily removed for repairs without unheading the barrel.

c represents the screw stem or spindle which operates the bung, said stem entering and working in the socket s' in the spider s , and causing the bung to move out or in when rotated.

If desired, the stem may be rigidly attached to the bung, so that both will turn together; but I prefer to adapt the stem to rotate in the bung independently, so that when the bung is in contact with the seat a^1 , and is being forced firmly into the same by the rotation of the stem, the packing will not be twisted and injured by the rubbing which would take place if the bung rotated. I also prefer to adapt the stem to have a slight longitudinal play in the bung to enable the barrel to be vented through the bung, as will be described. To these ends I make the bung and stem in separate parts, and connect them by any suitable means which will enable the stem to revolve and play longitudinally. In the present case the means employed are such as will admit of the ready removal of the bung from the stem if occasion requires.

I provide the bung with a central opening, d , adapted to receive the stem c , and provided at its lower end with a screw-thread, e . I also provide the stem at its upper end with a screw-

thread, *f*, and below said screw-thread, and separated therefrom by a space, *g*, I place a shoulder, *h*, on the stem, which acts as a seat for the bung. The threads *e f* are so constructed that they will engage with each other when the spindle is introduced into the lower side of the bung and turned in the proper direction, the thread *f* passing through the thread *e* until the thread *f* is entirely clear from and above the thread *e*, as shown in Fig. 1, the space *g* being longer than the longitudinal space covered by the thread *e*, so that the latter will project into the space *g*, and allow the spindle to have a slight longitudinal play in the bung, the thread *e* constituting a stop against which the thread *f* strikes when the stem is moved downwardly, while the bottom of the bung constitutes a stop against which the shoulder *h* strikes when the stem is moved upwardly. This arrangement thus enables the stem to move up and down to some extent in the bung, as well as to rotate therein, without moving the bung. The stem is provided in its upper end with a socket, *j*, to receive the end of a wrench, *k*, for rotating the stem. This socket is preferably undercut or recessed below its mouth or upper end, as shown in Fig. 3, the recessed portion being of the form in cross-section shown in Figs. 5 and 6, and the wrench is preferably made with a square end, which is larger than the shank of said wrench, as shown in Figs. 3, 4, and 7. The end of the wrench is of such size that it will enter and pass through the mouth or upper end of the socket *j*, and when the end of the wrench reaches the bottom of the socket, by turning the wrench, as shown in Fig. 5, the corners of the wrench will project under the mouth of the socket, as shown in dotted lines in Fig. 4, so that the wrench can be used to lift the stem and bung bodily without rotating them, as will be described, while by turning the wrench in the opposite direction it will be in position to be withdrawn from the recess, the walls whereof are so arranged that the wrench cannot be engaged to lift the stem when turned in the direction indicated by the arrow in Fig. 6. The stem is, by preference, threaded at its lower end only part way up to the shoulder *h*, and is reduced in diameter from the lower threaded end to the shoulder, for a purpose that will be explained. The thread on the lower end of the stem extends in an opposite direction from that of the thread *f* on the upper end thereof, so that when the spindle is being turned while the bung is made stationary by contact with its seat there will be no liability of the thread *f* engaging with the thread *e* of the bung to disconnect the bung from the spindle.

In operating my invention, supposing the bung to be in the hole when the latter is to be unstopped, the operator introduces the wrench *k* into the socket *j* and turns the stem *c*, as indicated in Fig. 6. This causes the stem and bung to descend, the thread *f* on the upper end of the stem bearing against the thread *e*

of the bung, and forcing the bung from its seat, and causing it to rest on the shoulder *h*. When the stem has been turned until its lower threaded end is disengaged from the threaded socket in the spider *s*, it drops with the bung until the shoulder *h* rests on the spider, the wrench being in the position shown in Fig. 6, and therefore offering no resistance to the descent of the stem and bung. The wrench is then withdrawn until it is desired to close the bung-hole, when the operator introduces the wrench and inserts it into the socket *j* in the stem, and gives the wrench a slight turn in the direction shown in Fig. 5, and thus engages the wrench with the stem, so that the latter can be lifted and turned in the last indicated direction, which causes the lower thread on the stem to be engaged again with the socket *s'*, and elevated thereby with the bung until the latter enters and stops up the bung-hole, the bung rotating with the stem until it comes in contact with the seat *a*², when it stops rotating, as above described, and is pressed firmly home by the stem. The operator then removes the wrench, the barrel being tightly closed and ready to be rolled freely without interfering with the bung, which is not allowed to project at all, but is somewhat retracted from the surface of the barrel, as shown in Fig. 1. When it is desired to vent the barrel without removing the bung from its seat, the operator turns the stem *c* sufficiently to separate the shoulder *h* from the bottom of the bung and bring the thread *f* of the spindle about down to the thread *e* of the bung, as shown in Fig. 3, the longitudinal movement allowed the stem, as above described, enabling this to be done without forcing the bung out of its seat. When this operation is effected the screw-threads *e f* form spiral vent-passages from the interior to the outside of the barrel, as indicated by arrows in Fig. 4. When the barrel has been properly vented, a turn or two of the stem closes the vent-passages, as will be readily seen.

I do not limit myself, however, to the use of the screw-threads *e f* for the purposes described, as any construction of parts whereby the stem is enabled to play longitudinally in the bung, and thus separate the shoulder *h* from, or bring it in contact with, the bottom of the bung, will be no departure from the spirit of my invention, the opening *d* in the bung being large enough to constitute a vent-passage.

I prefer to roughen or corrugate the lower surface of the shoulder *h*, and similarly roughen or corrugate the seat *h'* on the spider, on which said shoulder rests when the stem and bung are dropped, so that when the wrench is introduced and turned to engage it with the stem, as shown in Fig. 5, the stem will not rotate so easily as to render said engagement difficult of accomplishment, it being necessary that the stem should be stationary while the wrench is being turned. By only partially threading the lower end of the stem the op-

eration of raising and lowering the bung is greatly facilitated, as will be readily seen.

I prefer to provide the lower end of the stem with square double screw-threads, so that it will operate more rapidly. The upper end of the stem is preferably dished, as shown in Fig. 3, to facilitate the introduction of the wrench into the recess.

If desired, the shoulder *h* may be provided with one or more washers, *w*, preferably of rubber, to insure a tight fit of the bung on said shoulder.

It will be seen that the contraction of the outer end of the bushing and the provision of the flange *a'*, bearing against the inside of the barrel, prevent the bushing and its bung from being forced outwardly by the pressure of gas generated in the barrel. When the bushing is threaded on its outer surface and screwed into a wooden barrel from the outside of the latter, as usual, there is some liability of the bushing and bung being forced from the barrel by pressure from within, which liability I entirely obviate.

I claim as my invention—

1. A bushing, *a*, (adapted to be attached to a barrel or other vessel,) contracted at its outer end, and provided at its inner end with a socketed bridge or spider, *s*, projecting into the barrel, combined with a bung, *b*, adapted to enter the bushing from the inside of the barrel, and provided with a stem, *c*, socketed at its outer end to receive a wrench, and threaded at its inner end to engage with the socket of the spider *s*, as set forth.

2. The combination, in a beer-barrel or other vessel, of the seat or orifice *a*², contracted at its outer end, the fixed threaded socket *s'*, located inside of the barrel, and the bung *b*, adapted to enter the seat *a*² from within the barrel, and provided with the threaded stem *c*, adapted to engage with the socket *s'*, all as set forth.

3. The combination of a bung having a central opening, *d*, with a stem, *c*, having a shoulder or seat, *h*, and adapted to play longitudinally in the bung, said stem being provided with a screw-thread working in a fixed socket, *s'*, substantially as described.

4. The stem *c*, having the screw-thread *f* on

its upper end, and a shoulder, *h*, separated from said screw-thread by a space, *g*, combined with the bung *b*, having a central opening, *d*, provided with an internal thread, *e*, which is adapted to be contained in the space *g*, and form a stop which will permit the spindle to have a slight longitudinal play independently of the bung, substantially as and for the purpose specified.

5. The stem having at one end a right-handed screw-thread, and at its other end a left-handed screw-thread and an intermediate shoulder, *h*, separated from the thread at the upper end by an intervening space, *g*, combined with a fixed threaded socket, *s'*, in which the lower threaded end of the stem works, and a bung, *b*, having a central opening, which is internally threaded at its lower end, said internal thread being adapted to be contained in the space *g*, substantially as described.

6. The combination of a bung, *b*, adapted to enter its seat from within the barrel, a fixed threaded socket, *s'*, located inside of the barrel, and a stem, *c*, projecting inwardly from the bung, said stem being threaded at its inner end to engage with the socket *s'*, reduced in size between its threaded end and the bung, to slide freely in the socket *s'*, and provided in its outer end with a socket, *j*, adapted to be engaged, as described, with a suitably-formed wrench, *k*, substantially as and for the purposes specified.

7. The stem having the roughened or corrugated shoulder *h*, combined with the bridge or spider *s*, having the correspondingly roughened or corrugated seat *h'*, substantially as and for the purpose specified.

8. The bushing *a*, contracted at its outer end, and provided with a flange, *a'*, adapted to bear against the inner side of a barrel, and prevent the bushing and its bung from being forced outwardly, as set forth.

In testimony whereof I have signed my name to this specification in the presence of two subscribing witnesses.

PATRICK K. O'LALLY.

Witnesses:

C. F. BROWN,
L. W. FAIRCHILD.