

A. W. STRAUB.  
Mill Pick.

No. 202,299.

Patented April 9, 1878.

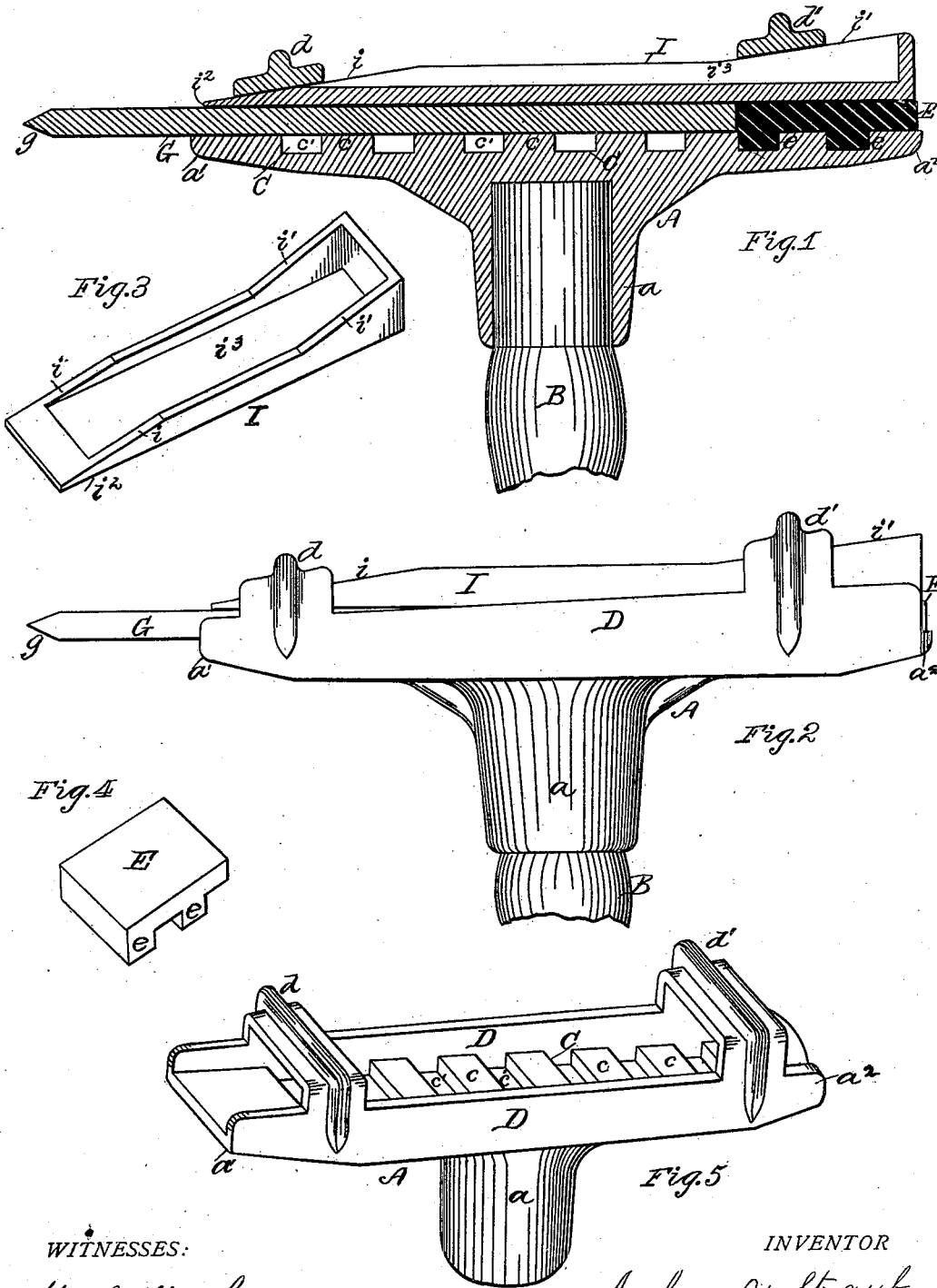

WITNESSES:

W. R. Kershner  
John Haines

INVENTOR

Ambrose W. Straub

# UNITED STATES PATENT OFFICE.

AMBROSE W. STRAUB, OF PHILADELPHIA, PENNSYLVANIA.

## IMPROVEMENT IN MILL-PICKS.

Specification forming part of Letters Patent No. 202,299, dated April 9, 1878; application filed October 30, 1877.

*To all whom it may concern:*

Be it known that I, AMBROSE W. STRAUB, of the city of Philadelphia, and in the county of Philadelphia and State of Pennsylvania, have invented certain new and useful Improvements in Mill-Picks; and I do hereby declare the following to be a full, clear, and exact description of the invention, such as will enable others skilled in the art to which it pertains to make and use it, reference being had to the accompanying drawings, which form part of this specification, in which—

Figure 1 is a vertical longitudinal section, Fig. 2 a side elevation, of my invention. Fig. 3 is a detail perspective of the wedge; Fig. 4, a perspective of the anvil-block; and Fig. 5 a perspective of the head of the pick.

The object of my invention is to provide a mill-pick of new and improved construction, whereby, in the operation of picking, I obtain an even and solid blow from the blade of the pick.

My invention consists in the employment of a straight blade, which abuts against an anvil-block which has on one of its sides projecting ribs or teeth, by means of which said anvil-block is held firmly in a rack formed in the head of the pick; said anvil-block is also adjustable on said rack so as to accommodate itself to the wear of the blade.

My invention further consists in the provision of a peculiarly-formed head for the pick, which is made box shape, and provided with a rack on its upper surface for receiving the teeth of an anvil-block.

My invention further consists in the employment of a wedge having one or more inclines formed on one of its sides, for instantly and securely locking together the various parts of which the pick is composed.

My invention further consists of the peculiar arrangement, combination, and construction of parts, as hereinafter more fully described.

Referring to the accompanying drawing, A is the head of the pick, formed with a socket-bearing, *a*, on its under side, for the reception of the end of the handle B. C is a rack cast on the upper side of said head A, and is formed with square or rectangular teeth and recesses *c* and *c'*. Said head is also provided

with upright sides D D, which are united by one or more cross-bars, *d d'*, which serve as bearings against which the inclines *i* and *i'* of the wedge I impinge, and securely locking the various parts of the pick together.

E is an anvil-block, having on one of its sides square or rectangular teeth or ribs *e e'*, which are designed to fit in the recesses *c' c'* of the rack C, while the body of the anvil rests on the upper surface of the teeth *c c*, between the upright sides D D of the pick A, thus forming a solid foundation for the end of the blade G to impinge against to receive the full force of the blow without springing said blade.

The anvil E is adjustable on the rack C, so as to take up the wear of the blade G. The latter is made straight, as shown, and is provided with a picking or cutting edge, *g*.

I is a wedge, having on one of its sides one or more inclines, *i* and *i'*, so that when it is placed within the head A, with its straight side *i<sup>2</sup>* resting on the blade and anvil-block, said inclines *i* and *i'* will respectively meet the cross-bars *d* and *d'* at the same time, and instantly lock said parts together. Said wedge, if desired, may be longitudinally recessed, as shown at *i<sup>3</sup>*, thereby decreasing the weight of the same and lessening the weight of the pick.

The operation is obvious: The anvil-block being placed in position in the rack C, so as to allow sufficient length of the blade to project beyond the nose *a<sup>1</sup>* of the head of the pick, the wedge I is placed in position, as shown, the inclines *i* and *i'* thereof instantly find their bearings beneath and against the cross-bars *d* and *d'* and lock all of said parts firmly and securely in the head A, every stroke of the pick tending to still further fasten and hold said parts more firmly in position. By reversing the position of the pick, and striking the same on its rear end *a<sup>2</sup>*, the wedge I is at once unlocked, and falls out of the head A by gravity. I thus obtain a mill-pick which is exceedingly strong but light in weight, all the parts thereof tending to support and give additional strength to each other, by reason of their position in relation to the manner in which they are locked together.

What I claim as my invention is—

1. A head for a mill-pick, formed with a socket-bearing for the reception of a handle, two upright sides united by cross-bars, and a rack or serrated surface, substantially as shown and described.

2. The head A provided with a socket-bearing, *a*, upright sides D D united by cross-bars *d* and *d'*, and a rack, C, having square or rectangular teeth and recesses *c* and *c'*, substantially as shown and described.

3. The wedge I, having the longitudinal recess *i*<sup>3</sup>, inclines *i* and *i'*, substantially as shown and described, and for the purpose set forth.

4. In a mill-pick, the combination of the straight blade G and adjustable anvil-block E, having teeth upon it which mesh into a

rack, C, formed permanently in the head of the pick, substantially as shown and described.

5. The combination of the head A, having upright sides D D united by cross-bars *d* and *d'*, the wedge I, having the inclines *i* and *i'*, substantially as shown and described.

6. The combination of the head A, formed substantially as described, the blade G, anvil-block E, and wedge I, substantially as and for the purpose set forth.

In testimony that I claim the foregoing I have hereunto set my hand this 26th day of October, A. D. 1877.

AMBROSE W. STRAUB.

Witnesses:

WELLINGTON R. KERSHNER,  
PETER HAY.