

J. HOCHHEIMER.  
Plaiting-Machine.

No. 202,346.

Patented April 16, 1878.

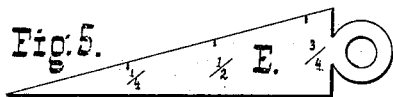
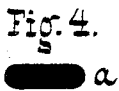
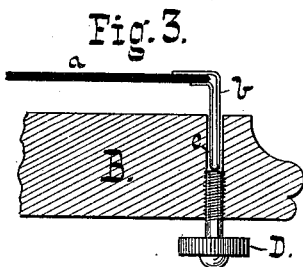
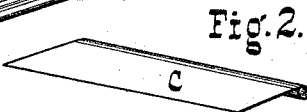
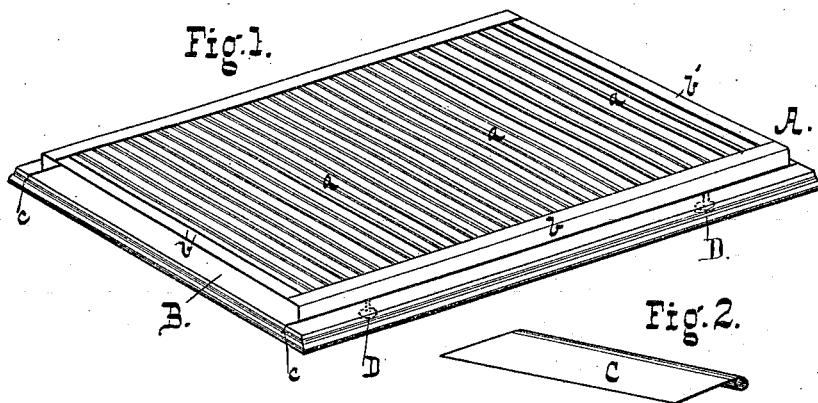

Witnesses,  
David G. Weiss.  
Dr. L. N. Barclay.

Inventor  
John Hochheimer.  
by  
R. W. Williams  
Attorney.

# UNITED STATES PATENT OFFICE.

JOHN HOCHHEIMER, OF BALTIMORE, MARYLAND.

## IMPROVEMENT IN PLAITING-MACHINES.

Specification forming part of Letters Patent No. 202,346, dated April 16, 1878; application filed March 26, 1878.

*To all whom it may concern:*

Be it known that I, JOHN HOCHHEIMER, of Baltimore city, State of Maryland, have invented certain new and useful Improvements in Plaiting-Machines; and I hereby declare the same to be fully, clearly, and exactly described as follows, reference being had to the accompanying drawings, in which—

Figure 1 is a perspective view of the plaiter; Fig. 2, a similar view of the knife; Fig. 3, a sectional view of a part of the plaiter; Fig. 4, a cross-sectional view of one of the needles; and Fig. 5, a plan view of the gage.

This invention relates, in general, to machines for forming plaits in textile fabrics, and, in particular, to that class of such machines as operate upon the principle of forcing the material, by means of a folder or knife, between a series of parallel slats or needles.

In such machines it has hitherto been customary to adjust the depth of the plaits (if at all) by means of a movable shoulder upon the knife; but this construction necessitated the exertion of such a degree of pressure in bringing the shoulder upon the knife into close contact with the fabric over the needle as resulted in causing the latter to bend, the plait being partially drawn out as the needle straightened upon the withdrawal of the knife. An obstacle was also met in the needles themselves. If cut from sheet material, the edges are liable to be either sharp or rough, or both, and, if round, they must necessarily be so thin as not to possess the requisite stiffness. Round needles are furthermore objectionable on account of their forming a bead on the edge of the plait as the latter is pressed.

My invention has for its object to obviate these defects in plaiters as heretofore constructed, and, at the same time, secure other and important advantages, as will be apparent.

In the accompanying drawings, A represents the plaiter proper, which consists of a rectangular frame, preferably of tin, having side pieces *b b*, turned over, as shown, at right angles to the frame. Within the frame are soldered or otherwise suitably secured the needles *a a*. These consist of metallic rods, preferably steel, having a shape in cross-section

as shown in Fig. 4—viz., that of a flattened oval. They are conveniently formed by rolling or flattening a mild steel wire, and subsequently cutting to the proper length and tempering. These needles answer every requisite. They are three times as stiff as a cylindrical needle of the same material and thickness, having a correspondingly greater cross-sectional area. Their breadth prevents the formation of a bead on the edge of the plait, and they possess all the advantages of cylindrical needles in respect to smoothness.

The base B is a suitable board, having a pair of grooves, *c c*, adapted to receive the side pieces *b b* of the plaiter. These grooves are cut about half through the board B, into the under side of which, and entering the grooves, are screwed the thumb-screws D.

It will be evident that as the side pieces *b b* rest upon the screws D within the grooves, the height of the needles *a* above the board B may be readily adjusted by turning the screws D. Fig. 3 illustrates this in detail.

The knife C is a simple strip of tin or other sheet metal, having a folded edge for the sake of smoothness.

A gage, E, provided with a scale, serves to indicate the height of the needles above the board.

In operation the plaiter is adjusted above the board to a height corresponding to the depth of the plaits to be formed. The fabric is then laid upon the frame, and is thrust between the bars *seriatim* by means of the knife C, which is caused to bring up against the board as each plait is formed.

It is obvious that the plaits are thus made of uniform depth, and the needles are subjected to no strain other than that caused by the fabric sliding over them, and this is reduced to a minimum by the smoothness of their surfaces.

Finally, when the plaiter is full or the fabric exhausted, the frame A is inverted, and the plaits are set by ironing over a damp cloth.

It is evident that, as an alternative for the adjusting-screws D, one or more thin bars or needles may be laid in the grooves, or other expedient adopted for raising the frame A to any desired height above the board B.

Having thus described my invention, what

I claim as new, and desire to secure by Letters Patent, is—

1. A plaiter consisting of a frame provided with parallel needles, and having devices for adjusting it to any desired height above a suitable base, substantially as described.

2. The plaiter A, vertically adjustable upon the base B, in combination with the folder C, substantially as described.

3. In combination with the plaiter A, having side pieces *b*, the base B, having grooves *c* and set-screws D, substantially as described.

4. A plaiter-needle having in cross-section the form of an oblate oval, substantially as described.

5. In combination with the base B, the vertically-adjustable plaiter A and gage E, substantially as described.

J. HOCHHEIMER.

Witnesses:

R. D. WILLIAMS,  
DAVID G. WINNS.