

M. MINAHAN.
 Device for Cutting Screw-Threads.

No. 202,362.

Patented April 16, 1878.

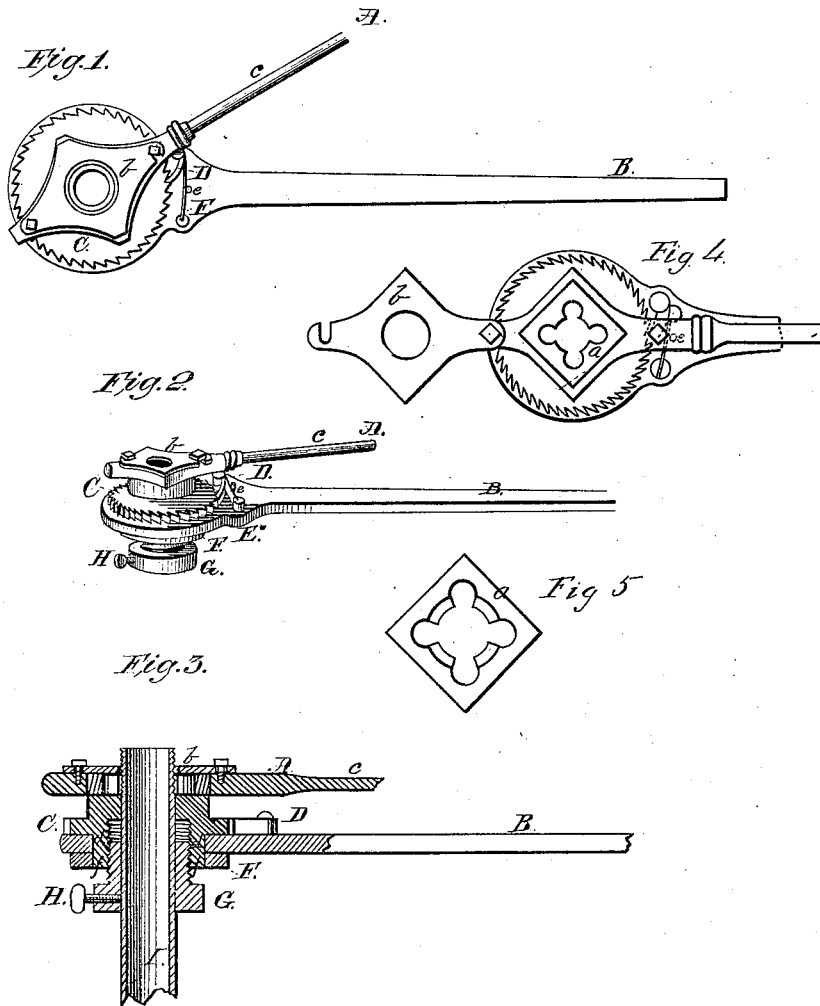

Attest:

Charles C. Strickler
 John P. Fidock.

Inventor:

Michael Minahan

UNITED STATES PATENT OFFICE.

MICHAEL MINAHAN, OF PORTLAND, OREGON.

IMPROVEMENT IN DEVICES FOR CUTTING SCREW-THREADS.

Specification forming part of Letters Patent No. 202,362, dated April 16, 1878; application filed May 11, 1877.

To all whom it may concern:

Be it known that I, MICHAEL MINAHAN, of Portland, in the county of Multnomah, in the State of Oregon, have invented an Improved Pipe-Stock, for use in cutting screws or threads on large pipe, and of which the following is a description, reference being had to the figures of the drawing herewith, and the letters of reference marked thereon.

Figure 1 represents a plan view of the invention. Fig. 2 is a perspective view. Fig. 3 is a longitudinal section. Figs. 4 and 5 are details.

The object of the invention is to secure increased power, in a manner readily applied, to a common "die-stock."

A represents a die-stock, having the contained die *a* and the swinging fastening-plate *b*. Its lever end is marked *c*. It is provided with a ratchet-flange, C. F indicates a collar, which is secured to the ratchet-flange in such a manner as to allow a space between the two, forming the journal *d* of the power-lever B. D represents a pawl, attached to the power-lever; and E, a pawl-spring, also attached to said lever, opposite the pawl, and so pivoted to its fastening-stud that it can be disengaged from and re-engaged with the pawl at will, the spring-bearing being secured by a back pin, *e*. G indicates the pipe-guide, threaded to engage with the neck *f* of the die-stock. H is a thumb-screw, and I the pipe to be cut.

To use the device, the pipe I is placed inside the guide G, and the thumb-screw H screwed firmly against it. If the main guide is too large, then one or more rings are placed inside, each having a hole in its side to allow the screw H to pass through to the pipe. The pipes being thus centered and held firmly in a pipe-vise, is now ready to receive the thread. The stock A is now taken and turned in the direction for cutting a thread, and in so doing the die is brought against the end of the pipe by the action of descending the guide-screw; and as soon as the die has fairly begun to work, very great strength is required to drive it, (some-

times several men are required,) and just here the power apparatus is applied. The pawl D being in gear, the long lever B is taken in hand, and the driving continued in the same direction. As soon as the die has well begun its work, the screw H is unloosed, and the cutting continued any required distance down the pipe.

The ratchet C is made in such way that the under side is turned for a center bearing for the lever B; and below, on the under side, a collar, F, is secured by proper screws or other fastenings, thus securing center of B firmly under the ratchet. The spring E is somewhat peculiar, in having a pin and center in one end, disengaging it when not required for action against the pawl C. For instance, it being required to reverse the die in taking it off, the end of E next the center of the pawl is raised up; D will now be easily thrown out of gear, and, by letting E fall again, may be kept quite clear of the ratchet, should care be taken to leave it between D and the ratchet.

The lever B may be made of any length, and in this way as much leverage may be obtained as may be required for any special case. The ratchet may be secured to the die-stock in any suitable way, by screws, rivets, or otherwise.

I claim—

1. The die-stock A, having the lever *c*, ratchet C, journal-bearing *d*, and threaded neck *f*, in combination with the collar F, pipe-guide G, and screw H, and power-lever B, journaled between said ratchet and collar, and having a spring-pawl for engagement with said ratchet, substantially as specified.

2. The combination, with the die-stock A, having a circular ratcheted flange, C, and journal *d*, of the power-lever B, its disengaging-pawl, pivoted spring E, and back pin or bearing *e*, substantially as specified.

MICHAEL MINAHAN.

Attest:

CHAS. C. STRICKLER,
JOHN P. FIDOCK.