

G. LENNARTSON.
Miter-Machine.

No. 202,445.

Patented April 16, 1878.

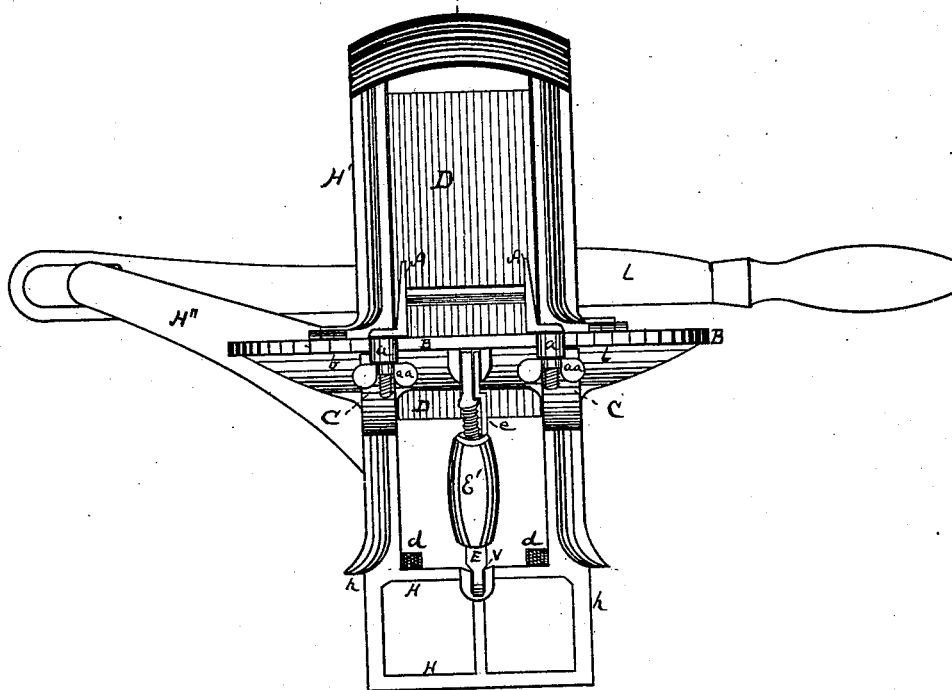

Fig 1 X

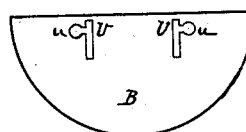

Fig 3

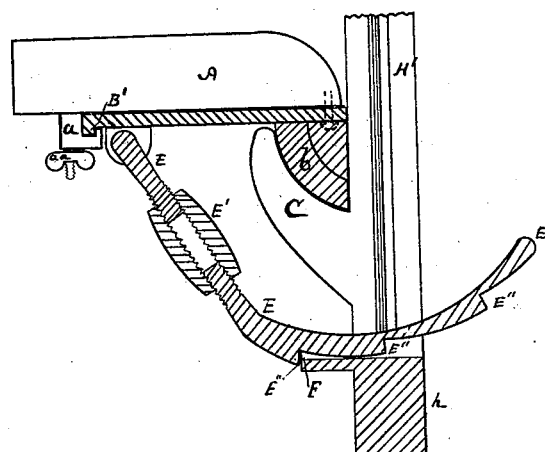

Fig 2.

WITNESSES

J. M. D. Meyerland.
Geo. A. Sturges

INVENTOR

Gustav Lennartson
by Sturges & Halllock
attys

UNITED STATES PATENT OFFICE.

GUSTAVES LENNARTSON, OF ERIE, PENNSYLVANIA.

IMPROVEMENT IN MITER-MACHINES.

Specification forming part of Letters Patent No. 202,445, dated April 16, 1878; application filed September 28, 1877.

To all whom it may concern:

Be it known that I, GUSTAVES LENNARTSON, of Erie, in the county of Erie and State of Pennsylvania, have invented a new and useful Improvement in Miter-Machines; and I do hereby declare the following to be a full, clear, and exact description thereof.

My invention relates to improvements in the construction of the miter-planing machine shown in Letters Patent of the United States No. 179,662, dated July 11, 1876, to myself and L. G. Berystrom, said Berystrom assignor to myself.

My invention consists in improvements in the construction of the various parts of said machine, as follows: First, of the frame; second, of the mode of operating the plane; third, of the table; fourth, of the means for adjusting the table; and, fifth, in adapting the machine more nearly to the wants of mechanics generally, by making it smaller, lighter, more compact, and easily portable—capable of being kept in a tool-chest and adjusted for use in the bench-vise.

My device is shown in the accompanying drawing, as follows: Figure 1 is a front elevation of the machine. Fig. 2 is a section on the line *x x*, Fig. 1, with the upper portion broken off. Fig. 3 is a plan view of the table.

The parts of the machine, as indicated by the letters of reference, appear as follows:

The frame-work is of one piece of cast-iron, *H'* being the uprights; *H*, the cross-pieces, and *h* the tenon-shaped base or foot; and *H''* is an arm, on which the actuating-lever is pivoted. The foot *h* is made tenon-shaped, so as to allow of the machine being properly set into the bench-vise; and it is so formed that it may be clamped on either side by the vise, as is seen in Figs. 1 and 2.

D is the plane, which operates the same as in the patent referred to—that is to say, vertically within grooves in the uprights *H'* *H'*. The plane *D* is operated by a lever, *L*, which is pivoted to the arm *H''*, and attached to the plane *D* in the proper manner. *d d* are rubber buffers, set in sockets in the uprights *H'* *H'* and on the cross-tie *H*, for the purpose of receiving the downward stroke of the plane.

B is the adjustable table, which is hung on the brackets *C* in such a manner that it can

be turned up to any angle desired. Thus far the construction of this table is the same as in the patent referred to. In this case this table is made of iron, being one solid piece of casting, and having on the under side of its periphery a rim, *B'*. (Fig. 3 is a plan view of the table.) This iron-plate table is perforated by two slots, *U U*, and by two holes, *u*, each of which open into one of the slots. These slots and holes serve the same purpose as the T-shaped grooves in the old device—that is to say, they are for receiving the lugs on the inner end of the guides *A* and assisting in the proper adjustment of the said guides. The clamps *a* on the outer ends of the guides are provided with an L-shaped lip or lug, which fits over the rim *B'*, and holds the clamp in place while the guides are being properly placed.

The outer edge of the table is sustained by a curved and notched brace, *E*, which is jointed to the under side of the table at its upper end, and at its lower end rests in a groove, *V*, in the cross-piece *H*. This brace is so arranged that the notches *E''* engage at *F* on the lower side of the groove. By changing from notch to notch the table is placed at fixed angles to suit the work in hand. Slight changes can be made in the angles by the screw *E'*, if desired. *e* is a clip, which, when the screw *E'* is set against it, insures the table being at the angle indicated by the notches *E''*. When any slight change of angle is desired by the use of the screw *E'*, this clip *e* has to be swung to one side.

My machine, as thus constructed, is much more compact, it is cheaper, and adapted for use as a bench tool. It is more easily and exactly adjustable, and more desirable in every respect.

What I claim as new is—

1. The combination, within the frame-work of a miter-planing machine, of the uprights *H'* *H'*, cross-pieces *H H*, arm *H''*, extending from uprights *H'*, brackets *C*, and tenon-shaped foot *h*, all said parts being arranged substantially as and for the purposes set forth.

2. In combination with the vertical acting plane *D*, the lever *L* and frame-arm *H''*, extending from uprights *H'*, as and for the purposes mentioned.

3. In combination with the plane D, uprights H' H', and lower cross-piece H, the rubber buffers *d d*, as shown, and for the purposes mentioned.

4. The cast-iron table B, with slots U and openings *u*, and ribbed periphery B', in combination with the guides A and clamps *a*, with L-shaped lugs for reaching over said rib B', as and for the purposes mentioned.

5. In combination with the adjustable table B and vertical acting plane D of a miter-planing machine, the curved and notched brace E and its support E'', for adjusting said table to the face of said plane, as set forth.

6. In combination with the adjusting-nut E', the gage-clip *e*, as shown, and for the purposes mentioned.

7. The combination, within a miter-planing machine, of the cast-iron frame, composed of grooved uprights H' H', cross-pieces H, arm H'', brackets C, and tenon-shaped foot *h*, to which frame are attached the table B and adjusting and sustaining brace E, the operating-lever L, and plane D, and the rubber bumpers *d*, all being arranged to operate as and for the purposes set forth.

In testimony whereof I, the said GUSTAVES LENNARTSON, have hereunto set my hand.

GUSTAVES LENNARTSON.

Witnesses:

JNO. K. HALLOCK,
MYRON E. DUNLAP.