

G. B. PHILLIPS.
Portable Forges.

No. 202,461.

Patented April 16, 1878.

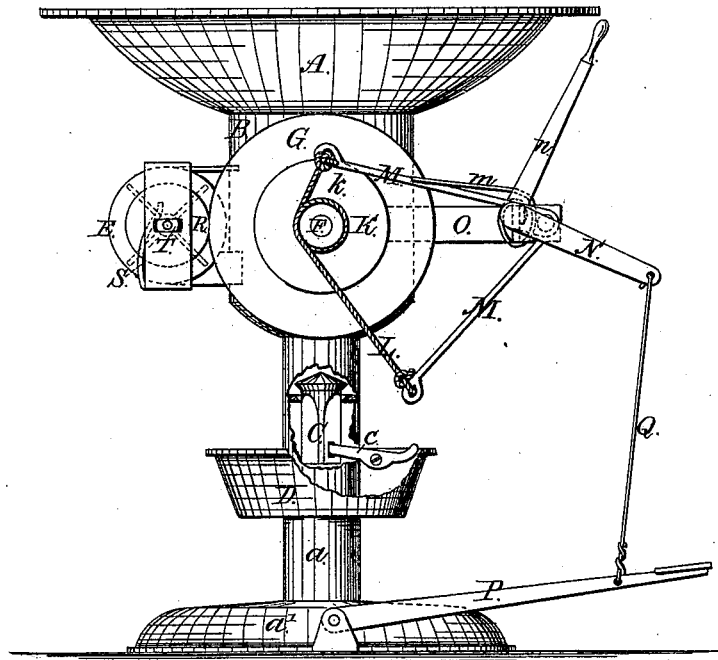

FIG. 1.

Witnesses.
E. A. Crawford
E. J. Benham.

Inventor:
GEORGE B. PHILLIPS.
by
William H. Low
Attorney.

G. B. PHILLIPS.
Portable Forges.

No. 202,461.

Patented April 16, 1878.

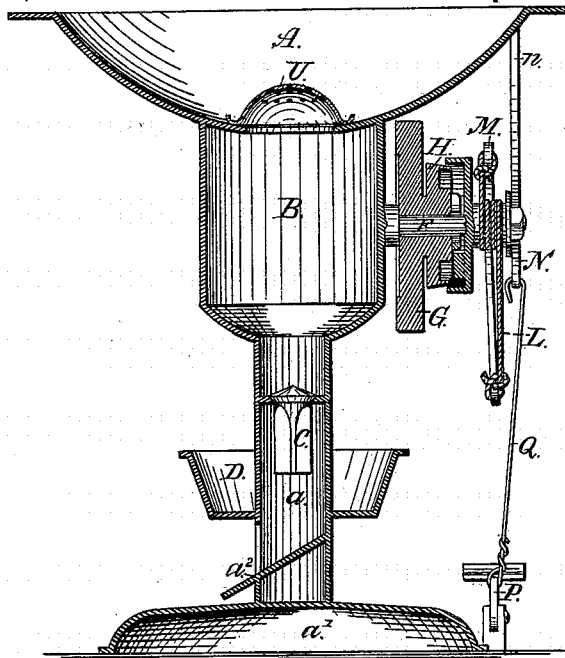

FIG. 2.

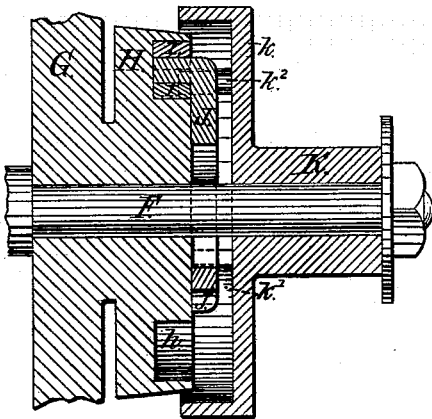

FIG. 3.

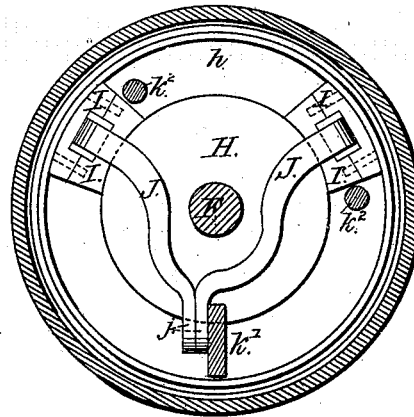

FIG. 4.

Witnesses.

E. Crawford.
E. J. Benham.

Inventor.

GEORGE B. PHILLIPS.
by
William H. Low
Attorney.

UNITED STATES PATENT OFFICE.

GEORGE B. PHILLIPS, OF BATH-ON-THE-HUDSON, NEW YORK.

IMPROVEMENT IN PORTABLE FORGES.

Specification forming part of Letters Patent No. **202,461**, dated April 16, 1878; application filed November 15, 1877.

To all whom it may concern:

Be it known that I, GEORGE B. PHILLIPS, of Bath-on-the-Hudson, in the county of Rensselaer and State of New York, have invented certain new and useful Improvements on Portable Forges, of which the following is a full and exact description, reference being had to the accompanying drawings, making a part of this specification, in which—

Figure 1 is a side elevation of my improved forge; Fig. 2, a vertical section, and Figs. 3 and 4 detached and enlarged details of the driving mechanism.

My invention consists of the combination and arrangement of the devices herein shown and described, for the purpose of producing a simple and effective forge, complete in itself, and ready at all times for immediate use.

As shown in the drawings, A is the top plate of the forge, which I preferably make of a dishing form. It is supported by the standard *a* and base *a*¹. It is provided with a tuyere-hole at its center, through which the air blast is discharged into the fire. An enlargement of the standard forms a chamber, B, for receiving the air-blast from the blower. At the bottom of this chamber is an opening for the discharge of the ashes falling from the forge into the chamber. This opening is closed by the cone-top valve C, which is operated by the lever *c*, projecting through the side of the standard *a*. After passing through the opening in the bottom of the chamber the ashes fall down upon the deflecting-plate *a*², and thence escape through an opening in the side of the standard. A trough, D, encircles the standard, which may be divided into compartments for holding coal, water, tools, &c.

E is a fan-blower, secured to the chamber B, into which it discharges its air; F, a stationary stud or shaft, (attached to the chamber B,) upon which the mechanism for driving the fan-blower revolves. This driving mechanism consists of the following parts: A fly-wheel, G, which revolves freely on the stud F, and which has a disk, H, provided with an annular groove, *h*. In this groove the split clamp-pieces I are placed, as shown in Fig. 4. These are provided with suitable openings at their joints for receiving the cam ends of the levers J, which, when pressure is applied

to the tails *j* of the levers, spread apart the clamp-pieces I with sufficient force to produce the frictional contact between them and the walls of the groove required to give motion to the fly-wheel G; K, a spool placed loosely on the stud F, on which it rotates in either direction. It is provided with a disk, *k*, having a short radial flange, *k*¹, which engages with the tails of the levers J when the spool moves in the right direction, and causes the clamp-pieces to expand, as before described, and bind the fly-wheel and spool together so that the two will move as one piece. The studs *k*² are fixed to the disk *k*, and are so arranged that as the spool is moved backward sufficiently to release the flange *k*¹ from the levers J, they (the studs *k*²) will strike against the ends of the clamp-pieces and release them from their hold in the annular groove, thereby leaving the fly-wheel free to continue its rotations by the force of its acquired momentum. L is the driving-cord, which, after passing several times around the spool K, has its opposite ends secured to the levers M. These levers should have elasticity enough to produce sufficient tension on the cord to create the adhesion required to drive the spool. Said levers are attached to the lever N, which is pivoted to the bracket O, secured to the chamber B. A spring, *m*, having its coiled end secured to the bracket O, has its free end bearing upon the upper one of the levers M with sufficient force to overcome the resistance of the weight of the treadle and its attachments. P is the treadle, fulcrumed to the base *a*¹, and connected to the arm N by the rod Q; R, a pulley on the shaft of the fan-blower E, running in frictional contact with the fly-wheel G, by which it is driven, and against which it is pressed by the spring S, which bears against the bearing T of the blower-shaft, which is movable for that purpose.

When it is required to operate the driving mechanism by hand instead of foot power, the rod Q is detached from the arm N, and the power applied to the hand-lever *n*, which may be detachable, if desired.

When the forge is used for melting precious metals, the perforated cap U, which covers the tuyere-hole by the upturned flange at its base, catches and retains the metal in case the cruci-

ble containing it should be broken while in the fire.

I claim as my invention—

1. The driving mechanism herein described, consisting of the fly-wheel G, provided with the annular grooved disk H, split clamp-pieces I, levers J, and spool K, provided with the disk *k*, flange *k*¹, and studs *k*², in combination with the driving-cord L and levers M, con-

structed to operate substantially as herein described.

2. The combination of the driving mechanism hereinbefore described with the blowing apparatus of a forge, as herein set forth.

GEORGE B. PHILLIPS.

Witnesses:

WILLIAM H. LOW,
E. A. CRAWFORD.