

M. SCHRENKEISEN.
Rocking-Chair.

No. 202,476.

Patented April 16, 1878.

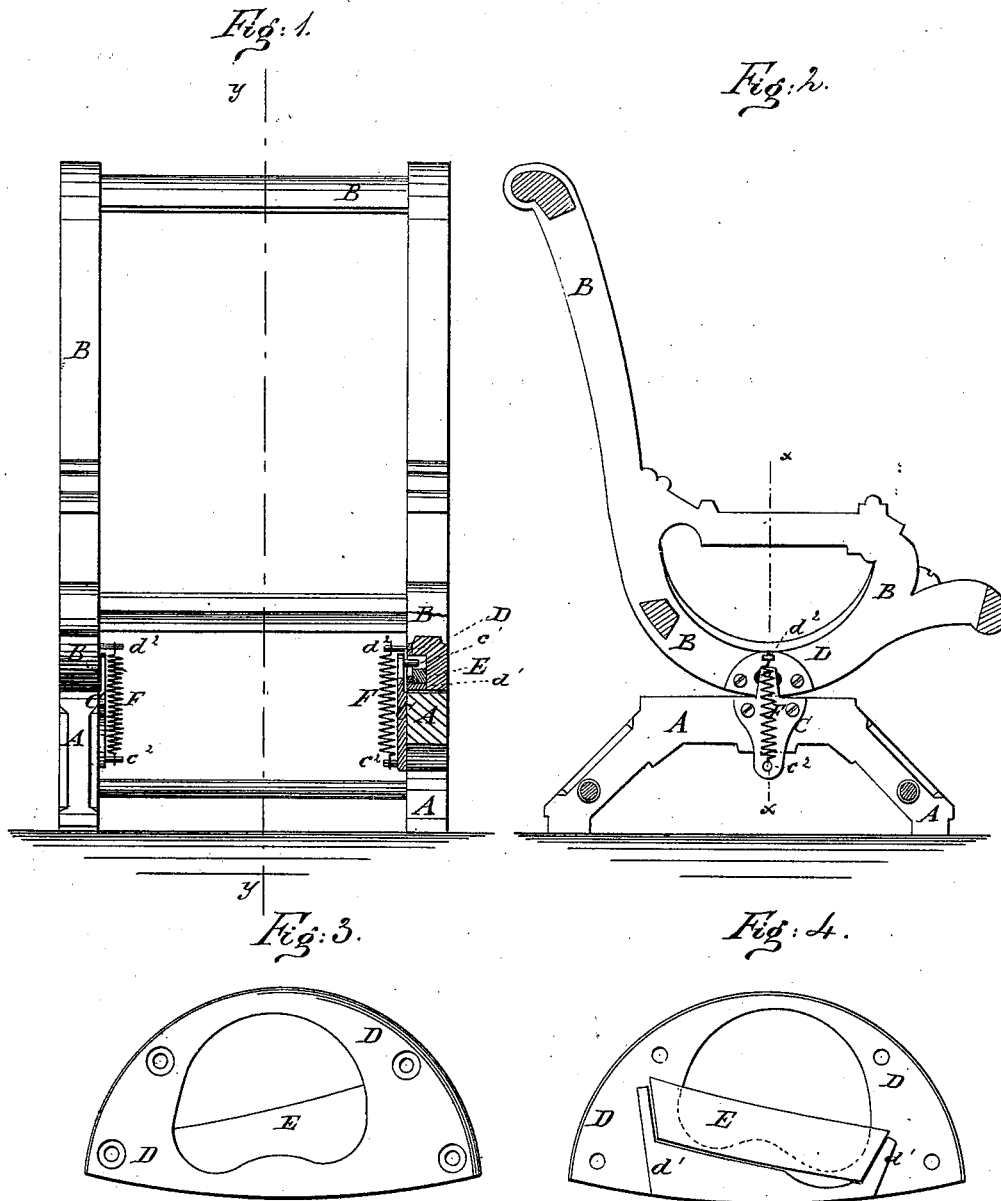

WITNESSES:

Chas. Nida
C. Sedgwick

INVENTOR:

M. Schrenkeisen
BY *Muntz*

ATTORNEYS.

UNITED STATES PATENT OFFICE.

MARTIN SCHRENKEISEN, OF NEW YORK, N. Y.

IMPROVEMENT IN ROCKING-CHAIRS.

Specification forming part of Letters Patent No. 202,476, dated April 16, 1878; application filed December 14, 1877.

To all whom it may concern:

Be it known that I, MARTIN SCHRENKEISEN, of the city, county, and State of New York, have invented a new and useful Improvement in Rocking-Chairs, of which the following is a specification:

Figure 1 is a vertical cross-section of my improved chair, taken through the line *x x*, Fig. 2. Fig. 2 is a vertical longitudinal section of the same, taken through the line *y y*, Fig. 1. Fig. 3 is a detail view of the outer side of the guide-plate. Fig. 4 is a detail view of the inner side of the guide-plate.

Similar letters of reference indicate corresponding parts.

The object of this invention is to furnish an improved rocking-chair of that class that rocks upon a stationary base, which shall be neat and simple in construction, and safe and reliable in use.

The invention will first be described in connection with the drawing, and then pointed out in the claims.

A is the base or pedestal of the chair, upon the upper edge of the side bars of which rest and rock the curved lower edges of the side frames of the chair B. To the inner sides of the side bars of the base A are attached plates C, called, by me "standards," the middle parts of which project along the inner sides of the bottom bars or rockers of the frame B, and have pins *c'* attached to or formed upon them to enter grooves in the plates D.

The plates D are attached to the inner sides of the rockers of the frame B, and have curved grooves formed through them to receive the pin *c'*, to serve as a guide to the said pin and keep the chair in place upon the base A while being used. Upon the inner side of the plates D are formed flanges or boxes *d'*, which project into a recess in the rocker of the chair B. The pin *c'* is made so long as to project through the plate D into the recess in the rocker B

and come in contact with the rubber block E as the chair B rocks forward and back.

The recess in the rocker B is so formed that the wood of the rocker may rest upon the upper side of the ends of the rubber block E, to hold it securely in place and prevent its ends from rising when the pin *c'* comes in contact with it.

The flange or box *d'* is recessed opposite the rear end of the groove in the plate D, to give more elasticity to the chair as it rocks back. The rubber blocks E prevent any sudden jar as the chair reaches the end of its forward and backward movements.

To the upper part of the plates D are attached, or upon them are formed, pins *d²*, and to the lower part of the standards C are attached, or upon them are formed, pins *c²*, to receive the ends of the spiral springs F. The pins *d² c²* have heads or projections formed upon them, or grooves formed in them, to prevent the ends of the said spiral springs F from slipping off them. The spiral springs F tend to draw the chair into and hold it in an erect position, and thus give it an easy, gentle, and regular movement.

Having thus described my invention, I claim as new and desire to secure by Letters Patent—

1. The combination, with the base A and recessed rocker B, of the plates D, having curved grooves, the plates C, having guide-pins *c'*, and the rubber block E, as shown and described.

2. The combination, with the chair-sections, having intermediate rubber E, of the boxes *d'* on plates D, and the pins *c'* on plates C extended through the plates D, as and for the purpose specified.

MARTIN SCHRENKEISEN.

Witnesses:

JAMES T. GRAHAM,
C. SEDGWICK.