

H. A. STEARNS.  
Machine for Folding Cotton-Batting.  
No. 202,480. Patented April 16, 1878.

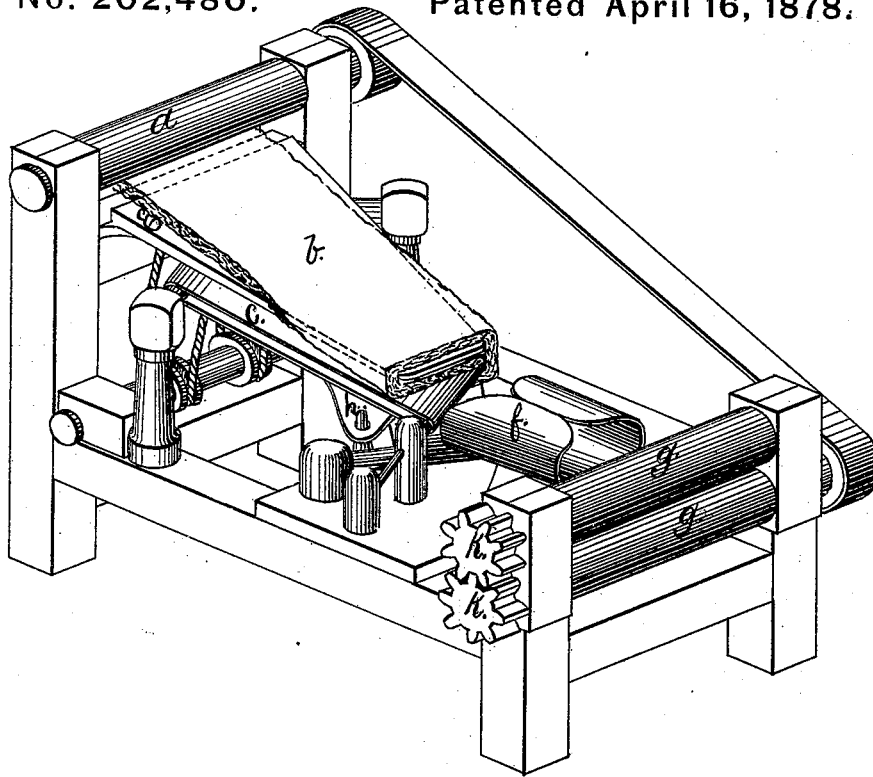

FIG. 1.

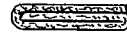

FIG. 5.

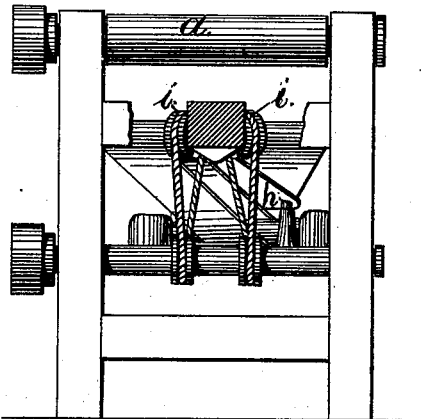

FIG. 2.

WITNESSES.

*Conrad C. Pauth*  
*J. A. Miller Jr*

INVENTOR.

*Henry A Stearns*  
by *Joseph A Miller*  
Attorney

H. A. STEARNS.  
Machine for Folding Cotton-Batting.  
No. 202,480.. Patented April 16, 1878.

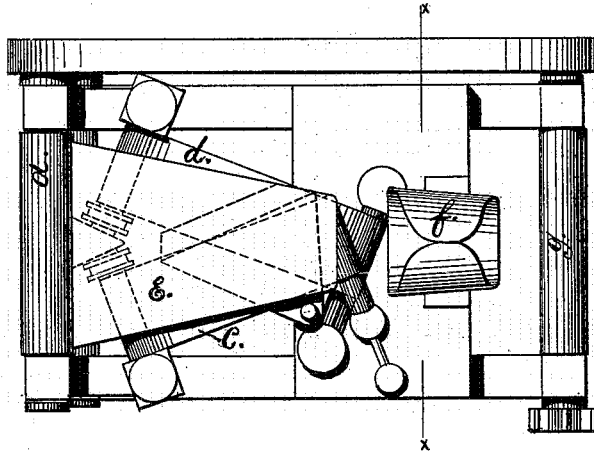

FIG. 3.

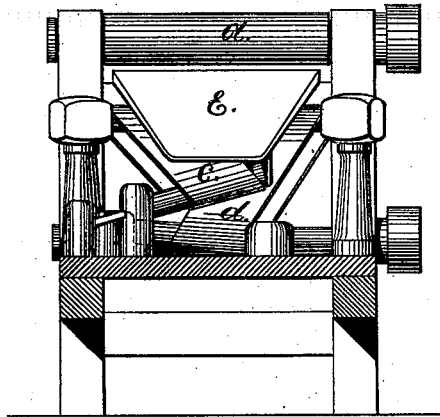

FIG. 4.

WITNESSES.

Ernest C. Barth.  
J. A. Miller.

INVENTOR.

Henry A. Stearns  
by Joseph A. Miller  
attorney.

# UNITED STATES PATENT OFFICE.

HENRY A. STEARNS, OF PAWTUCKET, RHODE ISLAND.

## IMPROVEMENT IN MACHINES FOR FOLDING COTTON-BATTING.

Specification forming part of Letters Patent No. 202,480, dated April 16, 1878; application filed May 20, 1876.

*To all whom it may concern:*

Be it known that I, HENRY A. STEARNS, of Pawtucket, in the county of Providence and State of Rhode Island, have invented certain new and useful Improvements in Machines for Folding Cotton Batting or Wadding; and I hereby declare that the following is a full, clear, and exact description of the same, reference being had to the accompanying drawings, forming part of this specification.

Figure 1 is a perspective view of my improved machine for folding batting or wadding. Fig. 2 is a rear end elevation of the same. Fig. 3 is a top view of the same, and Fig. 4 is a front elevation. Fig. 5 is a sectional view of the folded batting or wadding.

Similar letters of reference indicate corresponding parts.

The object of my invention is to produce a machine for folding cotton batting or wadding longitudinally, as it comes from the carding-machines, so as to compress the same into a narrower width for convenience of packing and transportation.

The invention consists in the peculiar arrangement of endless belts and funnel-shaped chute, composed of sheet metal or other suitable material having a smooth surface, and constructed so as to receive the sheet of cotton batting or wadding of the width as it comes from the cards, and fold the same by means of the endless belts and the sheet-metal chute, so as to fold the batting either into a double sheet, in which the edges meet in the center, or into a triple sheet, presenting one of the edges.

In the drawings, *a* is the delivery-roll, which may form the end roll of an endless apron, by which the batting or wadding is conveyed from the carding to the folding machine.

*b* represents the sheet of batting. *c* and *d* are endless belts or aprons, and *E* is the guide-board.

*f* is the sheet-metal chute. *g g* are the compressing-rolls.

*h* is a sheet-metal fender to separate the endless belts *c* and *d*, and keep them from interfering one with the other.

*i i* are the bands or belts by which the motion is transmitted to the endless aprons *c* and *d*.

*k k* are two gears placed on the rollers *g g*, to insure uniform motion of the same.

In operation, when the wadding or batting is to be folded longitudinally into three thicknesses, the guide-board *E* is arranged so that at its widest part it is as wide as the web or sheet of cotton-batting as it comes from the carding-machine, and made tapering so that its other end is of one-third the width of the batting. As the sheet of batting advances over the guide-board *E* the edges will hang down over the tapering sides of the guide-board, and be taken up by the endless belts *c* and *d*, and carried under the same, so that at the end of the guide-board the central one-third of the width of the batting will be on the board *E*, and one-third on each side be on each of the endless belts *c* and *d*, one below the other, as is shown in Fig. 5.

The so-folded batting now passes through the chute *f*, in which the folding is completed, and thence between the rolls *g g*, where the folded wadding or batting is compressed sufficiently for packing and transportation, as well as use.

By these means, the cotton batting or wadding is put in a convenient form for packing and transportation.

When it is desirable to have the cotton batting or wadding for use thinner than in its folded condition, the edges may very readily be turned back, so as to assume its original width and thickness.

By thus automatically folding the sheet of cotton batting or wadding, as it is delivered from the carding-machine, and turning the edges inward, about one-half the labor required in packing is saved. The sheets can be delivered cut into any desired length, and packed or rolled.

The value of the cotton batting is increased not only on account of its better and more marketable appearance, but as it can be unfolded without injury, there is less waste.

Having thus described my invention, I claim

as new and desire to secure by Letters Patent—

1. In a machine for folding cotton batting or wadding, the combination of the guide E, the endless belts *c* and *d*, and chute *f*, arranged and operating substantially as and for the purpose set forth.

2. In a machine for folding cotton batting

or wadding, the combination, with the guide E and endless belts *c* and *d*, of the chute *f* and rollers *g*, substantially as described.

HENRY A. STEARNS.

Witnesses:

JOSEPH A. MILLER,  
HORACE F. HORTON.