

G. S. BALL.
 Device for Holding Coin and Making Change.
 No. 202,507. Patented April 16, 1878.

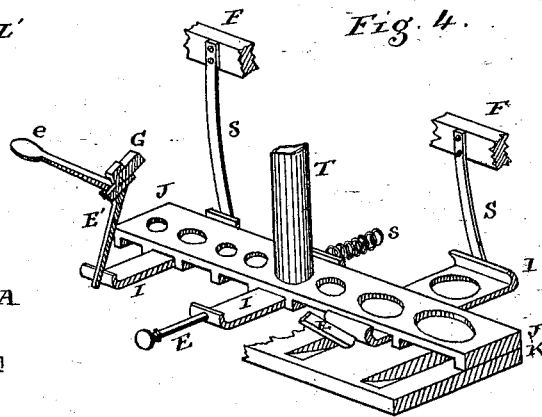
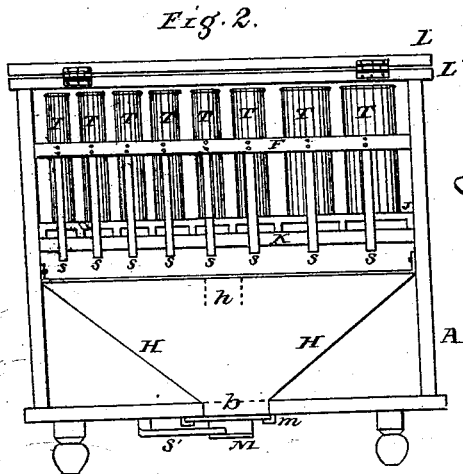
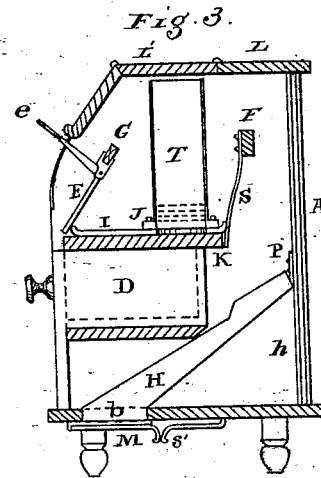
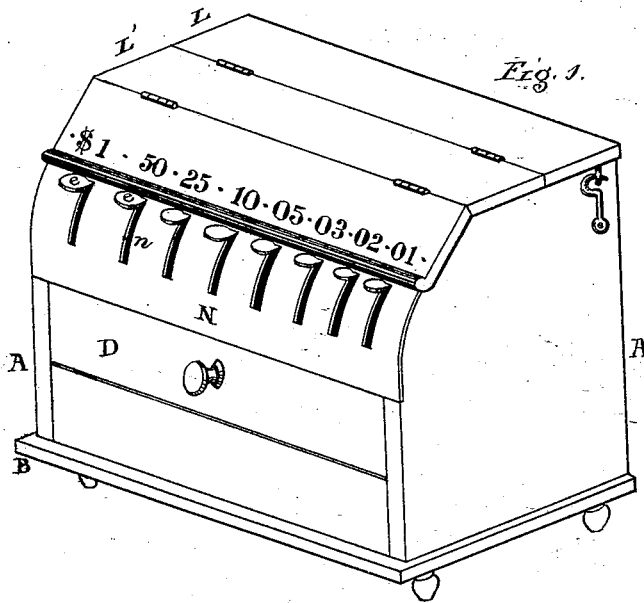

W. B. Miles
Jacob Stauffer
 WITNESSES:

Geo. S. Ball,
 INVENTOR

UNITED STATES PATENT OFFICE.

GEORGE S. BALL, OF LANCASTER, PENNSYLVANIA, ASSIGNOR OF ONE-HALF HIS RIGHT TO EDWARD J. ZAHM, OF SAME PLACE.

IMPROVEMENT IN DEVICES FOR HOLDING COIN AND MAKING CHANGE.

Specification forming part of Letters Patent No. 202,507, dated April 16, 1878; application filed March 19, 1878.

To all whom it may concern:

Be it known that I, GEORGE S. BALL, of the city of Lancaster, in the county of Lancaster, State of Pennsylvania, have invented certain Improvements in a Machine for Making Change Readily, of which the following is a specification:

The object of this invention is to drop the desired piece or pieces of coin into a common hopper by simply depressing the proper key, and the aggregate and exact change delivered to the hand at once, at a great saving of time and with the utmost certainty and accuracy.

The accompanying drawings, with the letters of reference marked thereon, and a brief description, will enable those skilled in the art to make and use said invention, and in which—

Figure 1 is a perspective view, as seen externally, the front side and top shown. Fig. 2 is an interior view, as seen from the rear by removing the sliding back. Fig. 3 is an interior side elevation, to show the arrangement of the parts; Fig. 4, a perspective view of a portion of the cross-bar, with its coin openings and ledges beneath, between which the sliding drop-valves are guided in dropping the coin; also, a modification of the lever by a rod and coiled spring.

The box A is of the required size to contain a series of tubes or cylinders of the diameter of the coin used to make change—one for each denomination. I show one for the silver dollar, fifty cents, twenty-five cents, ten cents, five cents, three cents, two cents, and one cent.

In Fig. 2 I show eight of the coin-tubes T. On a shelf, K, across the box, in Fig. 3, I show the arrangement of the device for operating. These tubes are attached to a plate, J, which plate has openings to agree with the diameter of the tubes, respectively, to receive the coin designed for it.

Guide-ledges project across the lower face of the plate J, between which ledges the drop-valves or slide-plates I have their motion. These sliding plates are turned up at the ends, and also have a circular opening to receive the coin of that tube over it near its rear end, so gaged by the pressure of a spring, s, and stop in front as to bring the coin-opening exactly under the tube to receive one of the coins

within the tube flush with its upper face over the shelf K. The projecting front portion of said plate I comes in contact with the arm E of an elbowed lever, E', having a key-plate, e, on its outer end, projecting through a slot, n.

In the curved covering-plate N, in front of the box, above each key e, is marked the numerical value of the coin contained in that particular tube, under which the plate slides by the action of said levers E E'.

D shows a drawer for notes or paper currency. H is a hopper, into which the coin drops and slides down into an opening, b, made centrally near the front in the bottom of the box. This has a door, M, sliding in side grooves or guides m, and kept in place by a spring, s', pressing against the turned-down end of the trap-door M.

The operation is as follows: The tubes being provided with the coin, respectively, and, as only a single piece can enter the drop-valve or slide at a time, I have just to depress the key of the desired coin. This pushes the valve back beyond the shelf, carrying the coin with it, whence it drops into the inclined hopper, to slide into the opening in the bottom of the box. For instance, I want to make change—say one dollar and eighty-four cents. I depress the keys marked one dollar, fifty, twenty-five, five, three, and one cent in quick succession with my right hand, and, pushing back the trap M beneath the box with my left, the amount desired—one dollar and eighty-four cents—will drop into the hand, and thus much time and confusion in hunting out the pieces is prevented. This provides not only a more ready way, but a safer way also, in making change in the hurry of business on market or in retail stores, and, being simple in its operation, it is found a highly-desirable device.

The sliding back of the box, as also the lids L L', as shown, were so made rather the better to exhibit the same than from any special necessity. I at first tried coiled springs, but prefer the flat.

I am not aware that a device substantially like this was ever known or used for the purpose of making change.

I will mention here that in my original design I connected the valve or drop-plate I with

a rod, E, having a button on it at one end, and the other connected with a coiled spring, but found that to push or pull would tilt the box; hence I adopted the lever, so as to apply the pressure rather vertically, besides being more convenient to operate. Therefore,

What I claim as my invention, in combination with a suitable box or cabinet, A, is--

A series of tubes or cylinders, T, attached to a cross-plate, J, which has coin-openings in the upper face and flanges across beneath to form guideways, the valves or drop-plates I

sliding between said guides, and also provided at one end with openings to receive the coin, shelf K, springs s, rods or elbowed levers E, hopper H, discharge-opening b, and spring-trap or sliding door M, the whole arranged and operated substantially as and for the purpose specified.

GEO. S. BALL.

Witnesses:

W. B. WILEY;
JACOB STAUFFER.