

S. M. FULTON.
 Device for Supplying Feed-Water to Boilers.

No. 202,535.

Patented April 16, 1878.

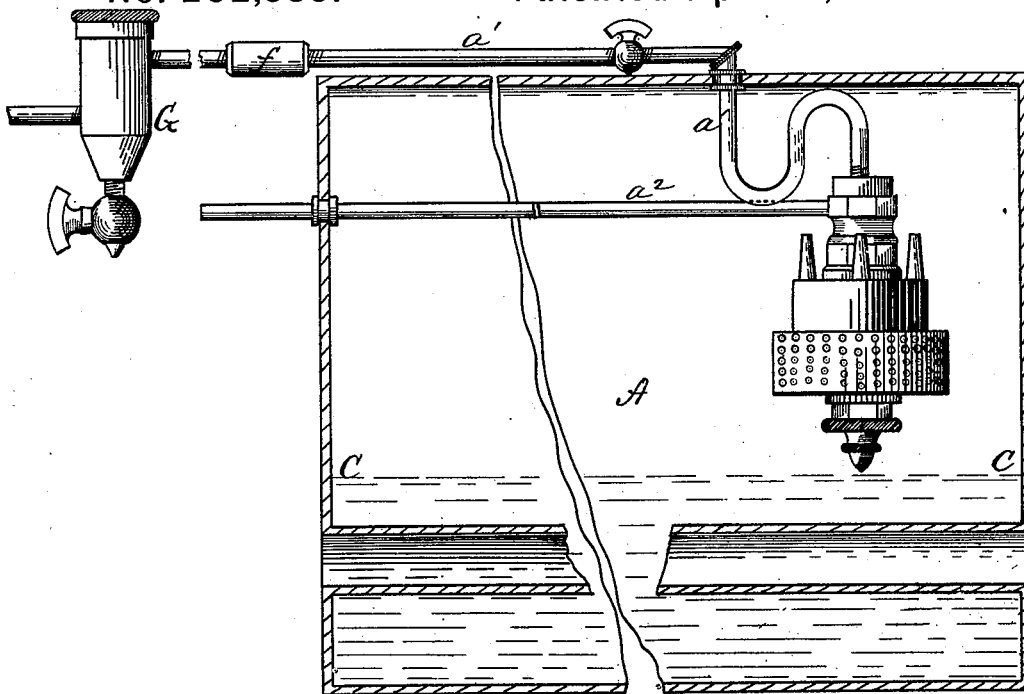

Fig. 1.

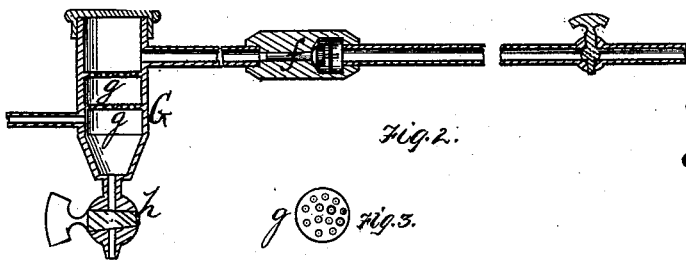

Fig. 2.



Fig. 3.

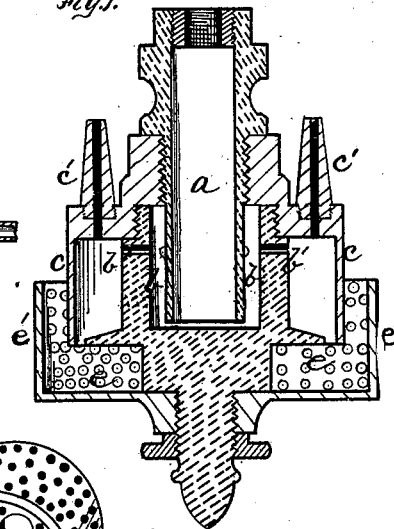
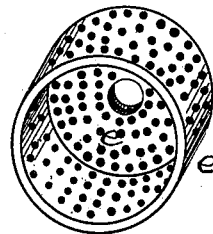

Fig. 4.



Witnesses.

R. W. Finshall
J. H. Smith

Inventor.

Samuel M. Fulton
 By *Bakewell & Ken*
Atty.

UNITED STATES PATENT OFFICE.

SAMUEL M. FULTON, OF PITTSBURG, PENNSYLVANIA.

IMPROVEMENT IN DEVICES FOR SUPPLYING FEED-WATER TO BOILERS.

Specification forming part of Letters Patent No. **202,535**, dated April 16, 1878; application filed March 7, 1878.

To all whom it may concern:

Be it known that I, SAMUEL M. FULTON, of Pittsburg, in the county of Allegheny and State of Pennsylvania, have invented a new and useful Improvement in Devices for Supplying Feed-Water to Boilers; and I do hereby declare the following to be a full, clear, and exact description thereof, reference being had to the accompanying drawing, forming part of this specification, in which—

Figure 1 is a sectional view of a boiler, my improved feed-water devices being attached, and shown in elevation. Fig. 2 is a detached view of my devices in section. Fig. 3 is a detached view of the screen of the exterior trap. Fig. 4 is a detached view of the perforated discharge-cup.

Like letters refer to like parts wherever they occur.

My invention relates to the construction and operation of devices for supplying feed-water to steam-boilers; and consists, first, in combining a trap with the discharge-tube of the supply-pipe within the boiler, whereby such impurities as require a high temperature to induce deposition are eliminated from the feed-water; secondly, in combining with the discharge-orifices of the feed-water device a perforated cup or box, so constructed as to insure the minute division of the feed-water and its dispersion in the steam-space of the boiler.

Various devices have heretofore been constructed for delivering the feed-water into the steam-space of boilers in the form of spray or in like finely-divided state, in order that by absorbing heat from the steam, &c., the feed-water should approximate the temperature of the body of water in the boiler before mingling therewith. The object in thus heating the feed-water is to prevent deposition of mud, &c., formation of scale, cracking of plates, foaming, irregular action of the boiler, formation of currents detrimental to even and uniform generation of steam, &c., and are too well known to the engineer and boiler-manufacturer to require more than a passing word here. But while the spraying of the feed-water into the steam-space of boilers has its advantages, its disadvantages also exist—as, for instance, the sudden reduction of pressure in the boiler whenever the feed-water is introduced, and

the liability to the formation of scale, &c., within the boiler, unless feed-water heaters are used.

The object of the present invention is, first, to substitute for expensive feed-water heaters, &c., simple and effective means for eliminating mud and other impurities tending to produce scale; and, secondly, to so comminute and deliver the feed-water that disturbance of the pressure and circulation in the boiler takes place to little or no material extent.

Certain features herein contained will be found in previous Letters Patent granted to me on the 1st day of January, 1878, and numbered 198,737, upon which the present invention may be said to be an improvement, though the main features of the present invention can be readily applied by the skilled mechanic in conjunction with other feed-water devices of the same class.

I will now proceed to describe my invention, so that others skilled in the art to which it appertains may apply the same.

In the drawing, A indicates a boiler, of tubular or other desired construction; and *c c*, the water-line therein. Secured in the steam-space of the boiler, at any appropriate point, are my feed devices, which are constructed as follows: *a* is a tube or pipe, into which the supply pipe or pipes open, said water-supply pipe or pipes (*a*¹ or *a*²) being introduced through the top or at one end of the boiler, as may be found most desirable under the attendant circumstances. The tube *a* is a dip-pipe, open at its lower end, and is inclosed by a chamber, *b*, perforated above, as at *b'*, forming a water seal and trap. Surrounding the chamber *b* is a hood, *c*, perforated above, and provided with a series of jet-tubes, *c'*, which take steam from the steam-space of the boiler. The hood *c* is open below, so that an annular discharge-orifice, *d*, is formed between the hood and the chamber *b*, and the parts *b c* dip in a box or flanged deflecting and delivery plate. *e* indicates the delivery cup or box, perforated or formed with fine orifices, and provided with perforated sides or flanges *e'*.

At suitable points in the supply pipe or pipes are arranged one or more check-valves, *f*, and on said pipes, without the boiler, is one or several traps, G. The trap or traps G may

be short cylinders or other-shaped receptacles, divided by one or more perforated screens, *g*, the receiving end of the water-supply pipe entering the receptacle *G* preferably upon one side of the screen *g*, and the discharge end leaving the receptacle on the opposite side, so that the feed-water on its way to the boiler is compelled to pass through the perforated plate or screen *g*.

The devices, being properly attached to a boiler, operate as follows: The feed-water entering by the supply-pipe passes through trap *G*, having its force arrested therein, and, passing through the screen, deposits mud, earthy matter, and such impurities within said receptacle, whence it can be removed from time to time through pipe *h*. The supply-water thus purified passes by the supply-pipe into dip-pipe or tube *a* and closed chamber *b*, in which interior or second trap it is subjected to heat, depositing therein such matter as is eliminated by heat and any remaining earthy matter. The pressure in the supply-pipe forces the water from chamber *b*, through holes *b'*, in fine jets or spray, which impinge against the hood or shield *c*, and are further comminuted. The mist thus formed is taken up, heated, and projected against the bottom of perforated box *c* by the steam entering the hood through jets *c'*. The fine spray or mist driven by the jets into the perforated box *c* escapes through the perforations of the same, is deflected by flange *e'*, and disseminated equally through the steam-space of the boiler. It will be found that,

owing to the minute subdivision of the water and the length of time it is retained under heat in the devices, there is much less reduction of pressure, and also that the several traps effectually remove impurities calculated to produce scale in the boiler.

Having thus described the nature and advantages of my invention, what I claim, and desire to secure by Letters Patent, is—

1. The combination, with the supply-pipe of a spray feed-water device arranged within the boiler, of a trap arranged thereon exterior to the boiler, substantially as specified.

2. The combination, with a spray feed-water device, of a trap arranged within the boiler, and formed by the end of the delivery-tube *a*, and inclosing chamber *b*, the whole constructed substantially as and for the purpose specified.

3. In a feed-water heater, the combination of the supply-tube, adapted to deliver the water in fine spray or jets, an inclosing-hood provided with steam-jets, and a perforated box or plate with perforated flange inclosing the free edges of the hood, substantially as and for the purpose specified.

In testimony whereof I, the said SAMUEL M. FULTON, of Pittsburg, aforesaid, have hereunto set my hand.

SAMUEL M. FULTON.

Witnesses:

R. H. WHITTLESEY,
F. W. RITTER, Jr.