

F. A. GOWER & M. J. MATTHEWS.  
Electro-Harmonic Telegraph.  
No. 202,539. Patented April 16, 1878.

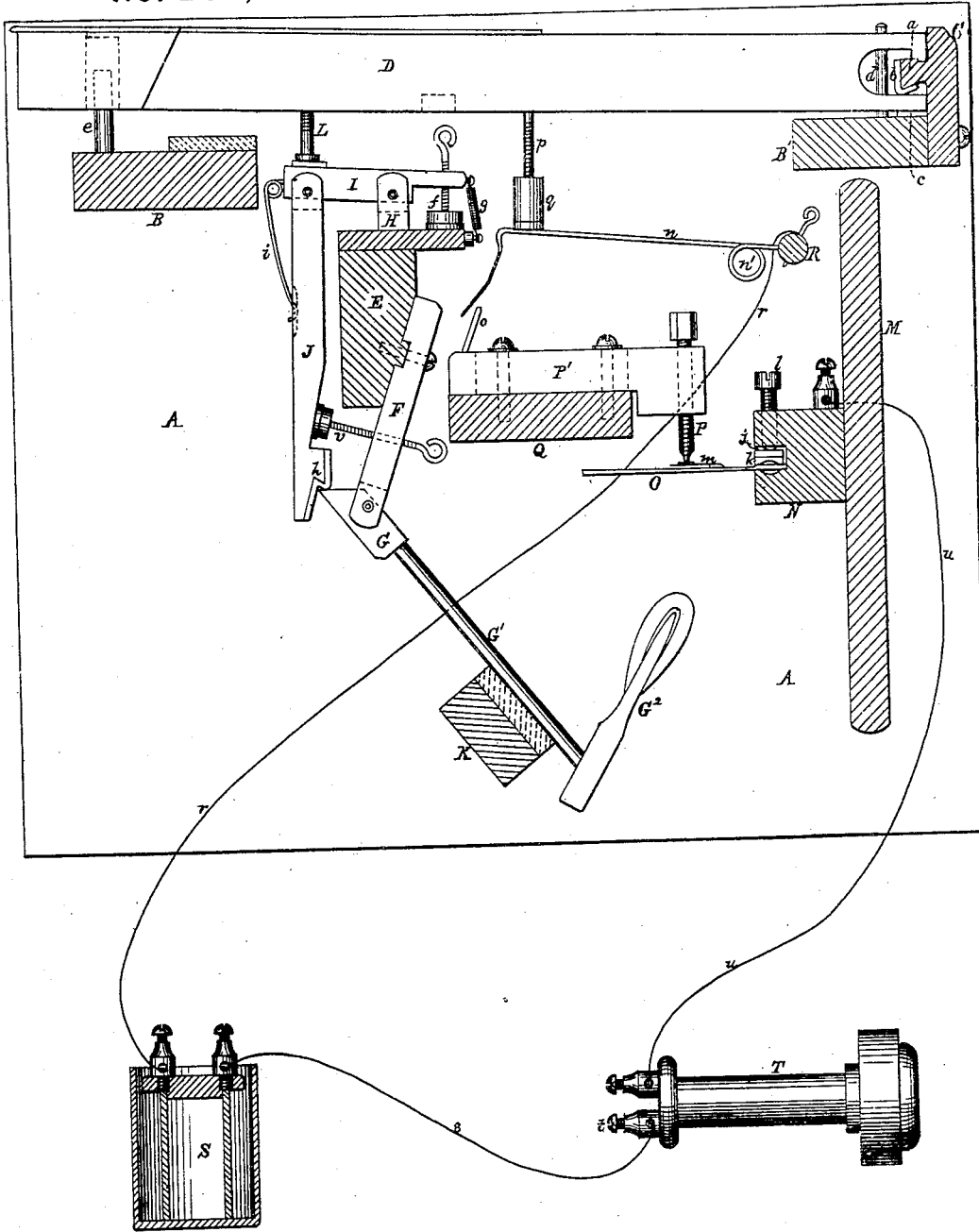

Fig. 1.

Witnesses:

*C. A. Hemmenway*  
*Bory Andrews, Jr.*

Inventors:

*Frederic A. Gower*  
*Mason & Matthews*  
by *N. C. Lombard* Attorney.

F. A. GOWER & M. J. MATTHEWS.  
Electro-Harmonic Telegraph.  
No. 202,539. Patented April 16, 1878.

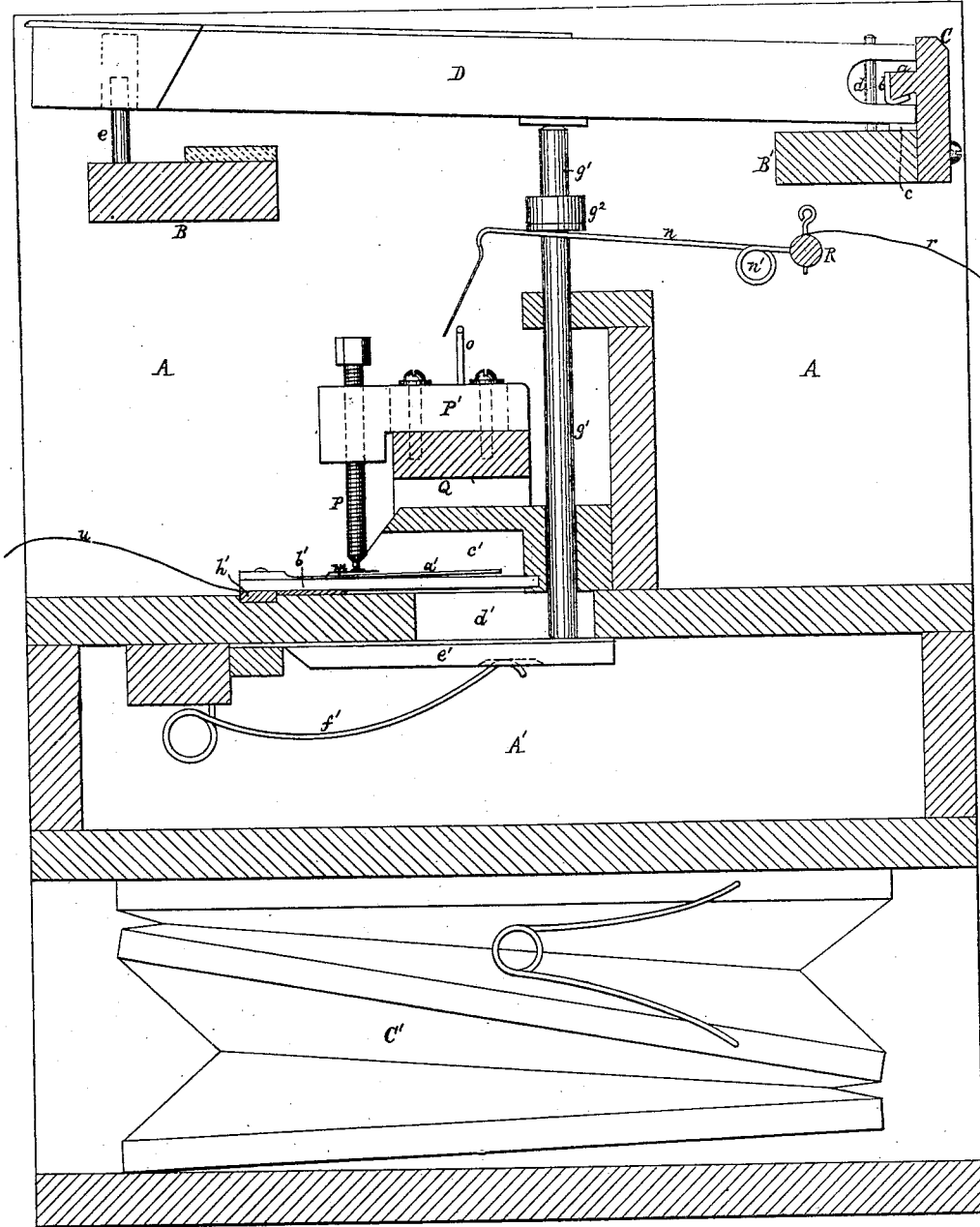

Fig. 2.

Witnesses:

*O. A. Kemmerway*  
*Benj. Andrews, Jr.*

Inventors:

*Frederic A. Gower*  
*Mason J. Matthews*  
by *N. C. Lombard* Attorney.

# UNITED STATES PATENT OFFICE.

FREDERIC A. GOWER, OF PROVIDENCE, RHODE ISLAND, AND MASON J. MATTHEWS, OF BOSTON, MASSACHUSETTS.

## IMPROVEMENT IN ELECTRO-HARMONIC TELEGRAPHS.

Specification forming part of Letters Patent No. 202,539, dated April 16, 1878; application filed January 23, 1878.

*To all whom it may concern:*

Be it known that we, FREDERIC A. GOWER, of the city and county of Providence, and State of Rhode Island, and MASON J. MATTHEWS, of Boston, in the county of Suffolk and State of Massachusetts, have jointly invented certain new and useful improvements in the art of transmitting musical sounds between distant points, of which the following, taken in connection with the accompanying drawings, is a specification.

Our invention relates to the construction of musical instruments, to be used, in combination with an electro-galvanic circuit and a telephone-receiving instrument, for the purpose of transmitting musical tones or telegraphing messages between points widely distant from each other; and has for its object the transmission of musical sounds between distant points with greater precision and purity of tone than has heretofore been accomplished, whereby a perfect harmony of tones may be produced at the receiving end of the line, and at the same time said tones are rendered more easily distinguishable one from another, so that messages may be easily read; and it consists, first, in the use, in a musical instrument, of one or more duplex vibrators, each composed of a primary metallic tongue or reed, adapted to produce a musical tone when set in motion, and a secondary or supplementary tongue or vibrator, secured to the primary vibrator, and adapted to vibrate with said primary vibrator, and also to have imparted thereto an independent vibration of its own, in combination with one or more adjustable contact-points, each in electric connection with the circuit of wire through which the musical tones are to be transmitted, and so arranged relative to one of said supplementary vibrators that said supplementary vibrator shall not touch it when in a state of rest, but will be brought into contact with said point at each vibration, and one or more keys and suitable mechanical action connected therewith, adapted to set said primary and supplementary vibrators in motion by percussion, "plectra," or by the movement of a column of air.

Our invention further consists in the use, in combination with a musical instrument provided with metallic reeds or vibratory tongues, and suitable keys and action for imparting motion to said reeds or tongues by percussion, plectra, or by the movement of a column of air, of a series of adjustable contact-points, each electrically connected with the circuit of wire through which the musical tones are to be transmitted, and so arranged relative to said reeds or vibratory tongues that contact will be made between said reeds or tongues and the points at each vibration of said reeds or tongues, and a series of circuit-closers, each connected with and operated by one of the keys of the instrument in such a manner that the depression of the key which sets the vibrators in motion to produce a musical tone closes the circuit between the vibrator set in motion and the main line of wire, thus permitting the vibrations produced thereby to be transmitted to the receiving-station in the form of the electric currents, and the releasing of the key causes the circuit to be broken, and the transmission of the electric current ceases, notwithstanding the vibrations of the reed or tongue may continue for some time after the circuit is broken.

Our invention further consists in the use, in combination with a musical instrument provided with a series of metallic reeds or vibratory tongues and a piano, organ, or other mechanical action, operated by a series of keys to mechanically impart motion to said reeds or tongues by percussion, plectra, or by the movement of air, of a series of secondary or supplementary tongues, secured one upon each of the primary reeds or tongues, so as to move therewith, a series of adjustable metal contact-points, each adapted to be electrically connected with the main circuit, over which messages are to be transmitted, and so arranged relative to one of said supplementary tongues that contact will be made between said point and supplementary tongue at each vibration of the primary reed or tongue, and a series of circuit-closers, each connected with and operated by one of the keys of the instrument, and adapted to close the circuit between one

of said contact-points and the main line of wire when its key is depressed, and to break it again when the key is released.

Our invention further consists in the use, in combination, of a line of wire, a battery, a transmitting-instrument provided with a series of metallic reeds or tongues, each having secured thereon a secondary or supplementary metallic tongue, a series of keys, a piano, organ, or other mechanical action connected with and adapted to be operated by said keys to impart a vibratory motion to said reeds or tongues, a series of adjustable contact-points, and a series of circuit-closers, each adapted to be operated by one of said keys, and to close or break the circuit between the main line of wire and one of said contact-points, and a telephone receiving-instrument connected to the opposite end of said main line of wire.

In the drawings, Figure 1 is a vertical transverse section of our improved instrument, which we term a "telephone-harp," adapted to be operated by percussion, and illustrating the method of connecting it electrically with a telephone hearing-instrument at the opposite terminus of the line over which messages are to be sent. Fig. 2 is a similar section of a wind-instrument having our improvements applied thereto, in which a vibratory motion is imparted to the duplex vibrators by the wind instead of percussion.

A represents a portion of one end of the case of the instrument; and B and B' are, respectively, the front and rear portions of the key-frame, extending from end to end of the instrument.

To the rear portion B' of the key-frame is secured the fulcrum-rail C, also extending from end to end of the instrument, and provided upon its front face with the lip *a*, having secured to its front and under face the strip of felt *b*, between which and the strip of cloth or felt *c*, resting on the bar B', is inserted the lower fork of the rear end of the key D, in a well-known manner.

The key D is held in position laterally by means of the fulcrum-pin *d*, inserted in and projecting upward from the bar B', and the guide-pin *e* set in the bar B and projecting upward into a slot in the key D, also in a well-known manner.

E is the action-rail, extending from end to end of the instrument, and having secured to its rear side, in an inclined position, a series of flanges, F, in the lower forked end of each of which is pivoted a hammer-butt, G, from which projects downward in an inclined position the hammer-stem G<sup>1</sup>, to the lower end of which is secured the hammer G<sup>2</sup>.

To the upper side of the action-rail E are secured a series of flanges, H, in the forked end of each of which is pivoted a short lever, I, provided at its rear end with the adjustable button, *f*, to serve as a stop to limit the movement of said lever in one direction, and the spring *g*, the tension of which serves to de-

press the rear end of said lever, and, as a consequence, raise its front end.

To the front end of the lever I is pivoted the jack J, which depends therefrom in a vertical position, and is provided at its lower end with the shoulder *h*, which is made to engage with the hammer-butt G by the spring *i* when the jack is in its highest position and the hammer-stem G<sup>1</sup> rests upon the rest-rail K.

L is a screw-pin set in the under side of the key, directly over the front end of the lever I, upon which its lower end rests, said pin being the medium through which the downward motion of the key causes a corresponding downward motion of the jack J and an upward motion of the hammer G<sup>2</sup>.

M is a sounding-board, extending across the instrument from end to end; and N is a metal rail, placed just in front of, and bearing at two or more points upon, said sounding-board, and having formed in its front edge a longitudinal groove, *j*, in which are secured, by means of a gib or clamp, *k*, and set-screw *l*, the steel tongues or vibrators O, all constructed substantially as described in Letters Patent No. 157,850, granted to Mason J. Matthews December 15, 1874.

A secondary or supplementary tongue or vibrator, *m*, made very much thinner and more delicate than the tongue O, is secured upon the upper side of the tongue O in a position parallel, or nearly so, thereto, and having the upper side of its free end faced with platinum, for a purpose to be hereinafter described. Directly above the platinum-faced free end of the supplementary vibrator *m* is a platinum-pointed set-screw, P, set in the metal holder P', secured upon the wooden rail Q, which extends from end to end of the instrument.

R is a metallic rod, extending the whole length of the interior of the instrument, and having set therein a series of coiled and bent spring-wire circuit-closers, *n*, projecting therefrom toward the front of the instrument and obliquely downward toward and into close proximity to the upper ends of the wires *o*, set in the metal holders P', as shown in Fig. 1.

A threaded pin, *p*, is set in the under side of each key D, and carries at its lower end the adjustable button *q*, adapted to rest upon the circuit-closer *n*, and press it downward when the key is depressed, and cause its thin spring-like end to come in contact with the wire *o*, and thus close the circuit, the circuit being broken again, as soon as pressure is removed from the key, by the tension of the spring of the coil *n*, causing the free end of *n* to move upward with the key, and thus separate from the wire *o*.

The metallic rod R is connected by a suitably-insulated wire, *r*, to one of the poles of a battery, S, the other pole of which is connected by the wire *s* to one of the poles *t* of a magnet in an ordinary telephone hearing-instrument, T, the opposite pole of said magnet being

electrically connected to the metallic vibrator-holding bar N by means of the wire *u*.

An adjustable cushioned button, *v*, is mounted in the flange F, for the purpose of limiting the backward motion of the lower end of the jack J.

In the modification shown in Fig. 2, where our invention is shown as applied to a wind-instrument, the key-frame B B', fulcrum-rail C, key D, contact-screw P, holder P', rod R, circuit-closing springs *n*, and contact-wires *o* are all constructed and operate substantially as before described; but the supplementary vibrator *m* is secured, in its proper position beneath the contact-screw P, upon the ordinary metallic reed *a'*, secured to the reed-frame *b'* in the usual manner.

Each of the reed-frames *b'* is fitted into a separate cell, *c'*, above an opening, *d'*, through the upper board of the wind-chest A', said opening *d'* being covered on its under side by a valve, *e'*, held in position by the spring *f'*, and opened by a downward movement of the push-pin *g'*, caused by a depression of the key D, all constructed and operated in a well-known manner. The push-pins *g'* are each provided with a collar, *g''*, adapted to engage with and operate the circuit-closer *n*, substantially the same as heretofore described in connection with Fig. 1.

A metal plate or bar, *h'*, extends lengthwise of the instrument under and in contact with the reed-frames *b'*, and is connected by the wire *u* to the magnet of a telephone hearing-instrument; and the rod R is connected by the wire *r* to a battery, from which another wire leads to and connects with the magnet of the telephone-instrument at the opposite terminus of the line, all as heretofore described.

The reed *a'* is made to vibrate by the passage of air through the cell *c'* and passage *d'*, caused by the operation of the bellows C' in a well-known manner.

When the primary vibrator *a'* or O is set in motion, either by the action of wind, by percussion, by wind and percussion combined, or by plectra, the supplementary and more delicate vibrator *m* is brought into contact with the point of the screw P at each vibration of the primary vibrator, thus communicating said vibrations to the electric wire, and through it to the diaphragm of the telephone hearing-instrument T at the opposite end of the line, it being understood that the telephone-harp is located at one end of the line, as at Boston, and the telephone-instrument at the other end of the line, as at New York.

The duration of the tone delivered in New York is determined by the length of time which the circuit-closer *n* is held in contact with the wire *o*, notwithstanding the vibrators may continue to move some time after the circuit is broken. This gives a sharply-defined effect to the note as heard at the point of delivery, and produces a quick response to the touch, which greatly facilitates the rapid transmission

of messages over long lines of wire on land, and is especially adapted to use in connection with ocean cables.

To this end we have arranged a musical alphabet, consisting of twenty-six distinctly different musical notes, each representing a different letter of the Roman alphabet, and adapted to be readily distinguished by the ear of the operator at the receiving-station.

The battery-power used by us consists of two or more cells "Leclanche," and an induction-coil of proportionate power; but it is obvious that the power or intensity of the battery, or both, may be varied to suit circumstances, or other styles of battery may be used.

The receiving-instrument used by us consists of a permanent magnet, either single or double—that is, either straight or of horseshoe form—with a coil of insulated wire upon the pole or poles, as the case may be, and a membrane or diaphragm of thin sheet-iron fastened in front of the pole or poles of the magnet, but not touching the same, it being substantially the instrument known as the "Bell telephone;" but other forms of the telephone may be used, and an electro-magnet may be used instead of the permanent magnet, if desired, without affecting the principles of our invention.

It will be obvious upon careful consideration that the form of action or the construction of that portion of the instrument by means of which motion is imparted to the primary vibrators may be very different from that shown in the drawings—as, for instance, the vibrators may be operated by a variety of percussive actions, by wind applied in a variety of ways, by wind and percussion combined, or by plectra, without in any way affecting the principle of the main features of our invention, as hereinbefore described and set forth.

The contact-screws and the supplementary vibrators are faced with platinum at the points of contact, to prevent the consumption of the metal of the supplementary vibrators; and the molecular changes in the platinum due to the passage and cessation of the current of electricity produce an important effect upon the delicacy of the contact, and thus upon the accuracy and purity of the tone.

We have found it possible to adjust the contact-screw so delicately to one of these supplementary vibrators as to produce a continuous note for two minutes after the large tongue had been struck by the hammer.

What we claim as new, and desire to secure by Letters Patent of the United States, is—

1. In combination with a musical instrument provided with a series of metallic reeds or tongues, each tuned to a different pitch, a series of keys, and a piano, organ, or other mechanical action, adapted to be operated by said keys, and to mechanically impart a vibratory motion to said reeds or tongues, a series of adjustable contact-points, each in electric connection with the main circuit of wire,

through which the musical tones are to be transmitted, and a series of secondary or supplementary metallic tongues, secured one upon each of said primary reeds or tongue in close proximity to one of said adjustable contact-points, but not touching it until it is thrown in contact therewith by the vibration of the primary reed or tongue, substantially as and for the purposes described.

2. In combination with a musical instrument provided with one or more metallic reeds or tongues, one or more keys, and one or more sets of piano, organ, or other mechanical action, adapted to be operated by said keys, and to impart a vibratory motion to said reeds or tongues, one or more adjustable contact-points, so arranged relative to said reeds or tongues that contact will be made between one of said points and a reed or tongue at each vibration of said reed or tongue, and one or more circuit-closers, each connected with and operated by one of the keys of the instrument, and adapted to connect one of said adjustable contact-points electrically with the main circuit of wire through which the musical tones are to be transmitted, substantially as described.

3. In combination with a musical instrument provided with one or more metallic reeds or tongues, one or more keys, and one or more sets of piano, organ, or other mechanical action, adapted to be operated by said keys and to impart a vibratory motion to said reeds or tongues, one or more secondary or supplementary metallic tongues, secured one upon each of said primary reeds or tongues, one or more adjustable contact-points, so arranged relative to said supplementary tongues that contact will be made between one of said points

and a supplementary tongue at each vibration of its primary reed or tongue, and one or more circuit-closers, each connected with and operated by one of the keys of the instrument, and adapted to connect one of said adjustable contact-points electrically with the main circuit of wire through which the musical tones are to be transmitted, substantially as and for the purposes described.

4. The combination of a line of wire, a galvanic battery connected therewith, a transmitting-instrument provided with a series of primary metallic reeds or tongues, each having secured thereon a secondary metallic tongue, a series of keys, a piano, organ, or other mechanical action, connected with and operated by said keys and adapted to impart motion to said reeds or tongues, a series of adjustable contact-points, so arranged relative to said supplementary tongues that contact will be made between one of said points and a supplementary tongue at each vibration of a primary reed or tongue, and a series of circuit-closers, each connected with and operated by one of said key, and adapted to close and break the circuit between one of said points and the main line of wire, and a telephone receiving-instrument located at and connected with the opposite end of said line of wire, all arranged and adapted to operate substantially as and for the purposes described.

Executed at Boston, Massachusetts, this 19th day of January, A. D. 1878.

FREDERIC A. GOWER.  
MASON J. MATTHEWS.

Witnesses:

N. C. LOMBARD,  
E. A. HEMMENWAY.