

C. McCARTHY & C. GILES.
Oil-Pump.

No. 202,565.

Patented April 16, 1878.

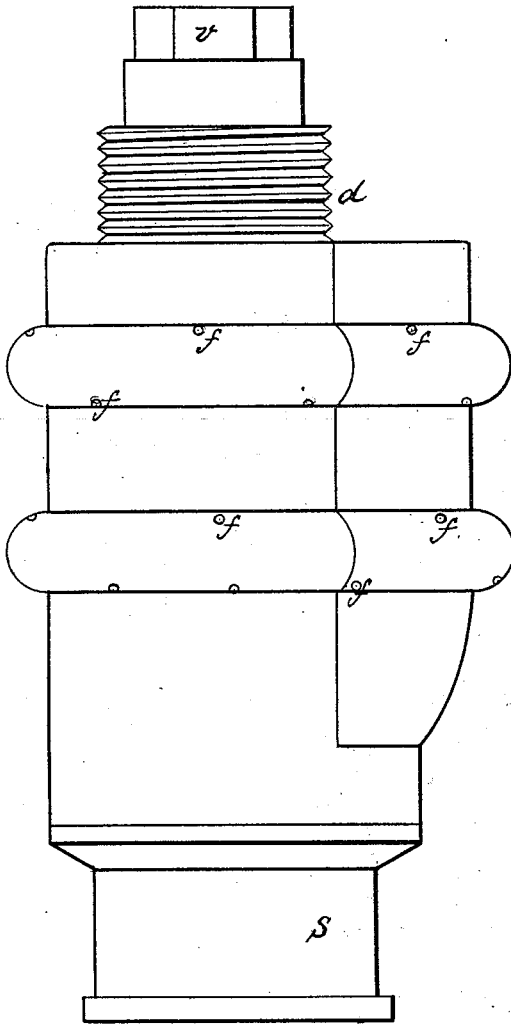

Fig. 1.

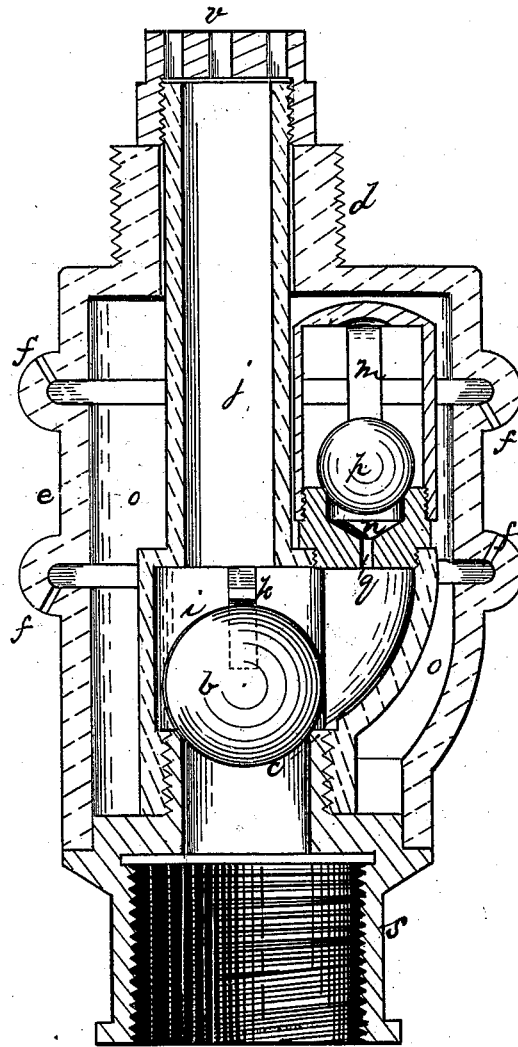

Fig. 2.

WITNESSES.

R. H. Whittlesey
Jacob Smith

INVENTORS

Cornelius McCarthy
Charles Giles

By Bakewell & Kerr
Attys

UNITED STATES PATENT OFFICE.

CORNELIUS McCARTHY, OF PETROLIA, AND CHARLES GILES, OF SUMMIT CITY, PENNSYLVANIA.

IMPROVEMENT IN OIL-PUMPS.

Specification forming part of Letters Patent No. **202,565**, dated April 16, 1878; application filed March 23, 1878.

To all whom it may concern:

Be it known that we, CORNELIUS McCARTHY, of Petrolia, Butler county, and CHARLES GILES, of Summit City, Venango county, State of Pennsylvania, have invented a new and useful improvement in Pumps for Oil-Wells; and we do hereby declare the following to be a full, clear, and exact description thereof, reference being had to the accompanying drawing, forming a part of this specification, in which—

Figure 1 is a side elevation of my improved valve for oil and similar well pumps. Fig. 2 is a vertical section of the same.

Like letters of reference indicate like parts in each.

In oil-well and other suction pumps there are two and sometimes three valves. They consist of what is called the "working-valve," which is, in fact, the ordinary piston of the pump having a valve opening on the downstroke to admit the fluid, and closing on the upstroke to retain and raise it. The second valve, known as the "standing valve," is a valve in the lower end of the working barrel below the working valve, which rises during the upstroke of the latter to admit the fluid into the barrel, and closes and retains it in the barrel upon the downstroke, the purpose being to hold the oil in the barrel, in order that the working valve may take its load. The third valve mentioned is simply a check-valve at the top of the working barrel, to relieve the working valve of the weight of the column of fluid in the pump-tube above.

It has been regarded as a fundamental necessity that the standing valve should be perfectly tight upon its seat, because, if it was not, the fluid would escape out of the barrel and retire before the piston on its downstroke, so that it could not get its load.

Recently, however, oil operators have been using what they term "leaky valves," which are standing-valves having small grooves or file-cuts in the seat, so that on the downstroke of the piston a portion of the fluid will be forced through the grooves back into the well.

In oil-wells the oil flows into the well from a porous, sandy layer or stratum, known as the "oil-rock." There is always more or less water in the well. The presence of

the water causes the paraffine in the oil to congeal or partially congeal, forming, with the water, a gumming substance, which adheres to the side of the well and closes up the crevices, so that in time the rock ceases to yield or produce oil. Various expedients, such as torpedoing, steaming, and washing the well with benzine, have been adopted to remove this deposit and reopen the crevices. The purpose of the so-called "leaky valve" is to produce an agitation or churning of the oil against the sides of the well, which will, in some degree, prevent or retard the clogging of the oil-rock by dissolving the paraffine, when it will be pumped out of the well. Below the standing valve of the pump, and secured to the end of the barrel, is a tube, which is called an "anchor," and is for the purpose of protecting the lower end of the pump.

The fluid enters the pump through openings or perforations in the side of the anchor near the lower end of the working barrel. It must stand in the well high enough to cover these holes, because if the air or gas can get into the holes no vacuum or partial vacuum can be formed in the working barrel, and consequently no fluid will be drawn up above the standing valve and the pump cannot work. As it is very injurious to the well to permit the water to stand on the oil-rock, the holes by which the oil is admitted into the pump are made at or near the lower edge of the oil-rock, while the oil flows into the well from its whole surface.

The effect of the churning or agitation of the fluid caused by the leaky valve is confined to that part of the well immediately around the perforations in the anchor, and cannot act upon the oil-rock above, where it is equally needed. Furthermore, the washing of the rock can be done only in a very imperfect manner through these holes, as the construction is entirely unfitted for such a purpose. When the seat of the standing valve is perfect at first it will wear evenly, and consequently will last a long time; but if there is an unevenness or imperfection in it the wear of the valve increases, and the valve is rendered useless in a short time. This is the effect of grooving the seat to make a leaky valve.

The wear of the valve-seat at the grooves soon renders it necessary to take out the pump and replace the worn seat by a new one, so that, in fact, the benefit to the well does not compensate for the wear of the valve-seats and the loss of time in replacing them.

My invention consists in an improved means of washing the sides of the well by a jet or jets of oil caused to be thrown against them from and by the operation of the pump. A secondary but very important feature of this apparatus is that it prevents the gas of the well from entering the pump, and causes it to be directed into the casing of the well, so that it is prevented from interfering with the working of the pump, and can be collected and utilized at the mouth of the well.

Serious difficulty is experienced in pumping oil-wells by reason of the presence of gas in the well. It flows into the well with the oil, and frequently, when the pressure is strong, it raises the valves and holds them open, and prevents the pump working. When it is not so strong, and is forced up with the oil through the tubing, it escapes at the mouth of the well and cannot be collected for use, except by means of expensive apparatus. I cause it to be separated from the oil, and directed up between the tubing and casing, so that when it rises to the mouth of the well it can be led away and used.

Ordinarily the seat of the standing valve is made in this part of the working barrel. The ball *b* in such case is inside of the barrel and upon the seat, the latter being similar to the seat *c*, which is of the ordinary and well-known form. The lower end of the barrel was provided with a thread similar to the thread *d*, and into it was screwed the section of pipe which was known as the "anchor," of which we have already made mention, and which was perforated all around its upper end for the admission of the fluid from the well into the pump.

By means of the thread *d* I attach a shell, *e*, to the working barrel. This shell *e* is perforated at its sides, as at *f*. Inside of the shell *e* is a shell or valve-chamber, *i*, having a pipe, *j*, which extends up through the shell *e*, and is secured by a perforated nut, which brings the shoulder of the anchor-thimble *s*, attached below to shell *i*, against the bottom of the shell *e*, closing the same and connecting the parts. The chamber is provided with radial wings *k*, which extend inward from the shell, and form a cage over and around the ball *b*. The valve-seat *c* is formed with anchor-thimble *s*, and is screwed into the shell *i*.

These parts, connected as specified, will form an annular chamber, *o*, between shell *i* and the perforated shell *e*. The pipe *j* extends up through the opening at the top of shell *e* and closes the upper end of said chamber *o*.

Arranged on one side of the shell *i* and inclosed by shell *e* is a cage, *m*, inclosing a ball, *p*, or similar valve, which covers and controls

a port, *q*, or channel connecting the interior of shell *i* above the standing valve *b* with the chamber *o* between the shells *i* and *e*. Said port *q* is provided with a funnel or cone shaped valve-seat, *n*, having a small perforation at the apex. This opening can be enlarged to permit the passage of a larger amount of oil to the chamber *o* at each stroke of the piston and the original seat retained, or the seat can be changed, according to the requirements of the well.

On the upper end of the pipe *j* is a perforated cap, *v*, placed there to prevent worn packing-leathers, nuts, and other things which are liable to become loose from the piston from falling into the lower valve-chamber, said nut, as before specified, serving also to connect the shells *i* and *e*.

We will now describe the operation of the apparatus. An anchor-pipe of the desired length is screwed into the lower socket or thimble *s*. This pipe is perforated at any desired point, it not being necessary to make the holes close to the standing valve of my improved pump. The pump is placed in the well in the usual way, but will stand farther up in the sand, which brings the perforations *f* of shell *e* opposite the producing sand. At the upward stroke of the piston the valve *b*, rising, permits the entrance of the fluid into chamber *i*, filling it and the pipe *j*, and passing up into the working barrel *a*.

On the downstroke of the piston the valve *b* closes, and the valve *p* rises by the pressure of the liquid, and permits a portion of the oil to pass through the hole or ports *q* into the annular chamber *o*, whence it is ejected in minute streams through the perforations *f* against the walls of the well. By this means the walls of the well are washed, and the deposition of the paraffine retarded and in a large degree prevented. Upon the upward stroke of the piston the valve *p* drops down upon its seat, closing the ports *q*. The oil which passed through the perforations *f* goes back into the well and feeds the pump—that is to say, furnishes fluid for it to work on.

The flow of oil into the well is usually insufficient to supply the pump, and after pumping awhile the fluid in the well is pumped out below the holes in the anchor-pipe, and then the air and gas in the well are pumped out until a partial vacuum is formed in the well. In pumping, the whole weight of the column of oil in the tube rests on the piston and its rods. When the piston descends the whole column descends with it. When it happens that there is a partial vacuum in the well the descending piston and its load receive no support from below, as it would in case there was a steady upflowing stream of oil. Consequently it falls with great weight, and strains and jerks the sucker-rods and the operating machinery. To prevent this injurious effect, it has been customary to make use of a check-valve, sliding on the sucker-rods, and having its seat on the

upper end of the working-barrel, the result being that the weight of the column is sustained by the check-valve on the downward stroke of the piston.

Now, we obviate the necessity of using a check-valve, because the oil that is raised by the piston first fills the chamber of shell *l*, and the rest passes up through pipe *j* into the working barrel. The oil which filled the chamber *o* flows back into the well and covers the holes in the anchor-pipe, so that the next upstroke of the piston finds oil to work on, which, although it may not be sufficient to produce a discharge from the mouth of the well, still is enough to prevent the formation of a partial vacuum below. With the sufficient accumulation of oil in the well the yield from the mouth will begin again.

It will be observed that even when there is but little oil in the well the walls are constantly washed by the jets from the perforated shell *e*, because, when there is not enough oil to lift the working valve, the downstroke of the working valve will force the oil into chamber *o* and through perforations *f*.

As has been observed, when a leaky valve was used it was necessary to have the supply-opening of the anchor-pipe near to the standing valve, in order that the agitation which would be produced by forcing back a portion of the oil into the well may act through them.

With our device we can have the supply-openings of the anchor-pipe a considerable distance down, so as to bring the perforated chamber *e* high up on the oil-rock. This distance is limited only by the length of the stroke of the piston and its consequent power to raise the oil above the standing valve. With the leaky valve the entire effect produced was the agitation of the fluid at the lower part of the well. By our method the sides of the well are washed by the streams of oil from the perforated shell, and this washing is continued during the whole time the pump is working. Furthermore, the standing valve remains uninjured, and will wear a long time.

The openings in the anchor-pipe being kept covered by the oil, the gas which flows into the well cannot enter the pump-tube, and consequently rises into the casing, through which it passes to the mouth of the well, whence it may be led for use at any desired point.

What we claim as our invention, and desire to secure by Letters Patent, is—

1. The method herein described of priming or feeding the pump, consisting in forcing out of the perforated sides of the pump at the downstroke of the piston a portion of the oil which had been previously raised above the standing valve, so that it may flow back into the well, substantially as described.

2. The combination of the standing valve and the standing-valve chamber with a surrounding chamber, having perforated wall, and a valve controlling the communicating ports between the said chambers, operating substantially as and for the purposes set forth.

3. The combination of the cap *v* with the stand-pipe of the lower valve-chamber and the shell *e*, substantially as and for the purposes described.

4. An oil-well pump having a lower chamber provided with an outer perforated shell and a valve which shall be raised by the downward stroke of the piston, so that a portion of the oil in said lower chamber shall be ejected through the said perforations, substantially as and for the purposes described.

5. The combination of the ball-valve and the cup, with funnel-shaped extension, forming a valve-seat, perforated at the apex, whereby the size of the passage may be enlarged, substantially as and for the purpose specified.

In testimony whereof we, the said CORNELIUS McCARTY and CHARLES GILES, have hereunto set our hands.

CORNELIUS McCARTY.
CHARLES GILES.

Witnesses:

WILL S. WESCOTT,
J. H. LEWIS.