

J. W. PALMER.
Pump.

No. 202,577.

Patented April 16, 1878.

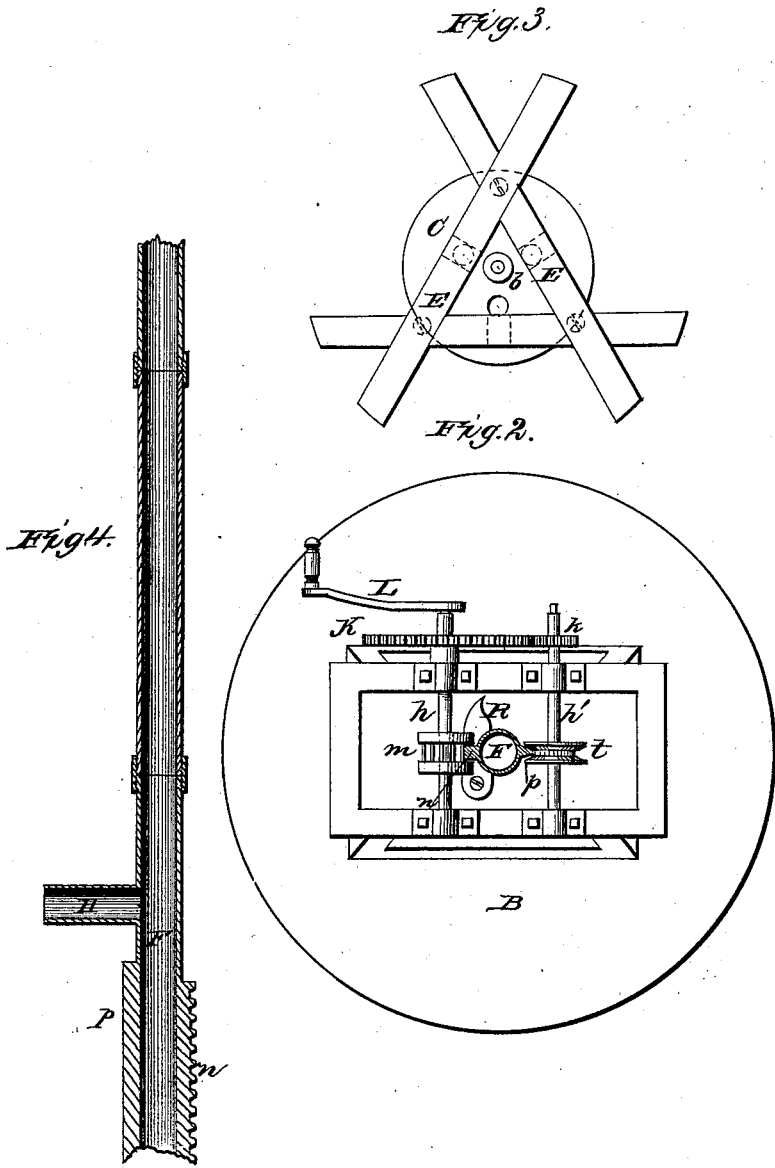

WITNESSES
Frank L. Conrad
Jerry M. Barthy

INVENTOR
Jos W. Palmer
Hander Mason
ATTORNEY

UNITED STATES PATENT OFFICE.

JOHN W. PALMER, OF PORT REPUBLIC, ASSIGNOR OF ONE-HALF HIS RIGHT
TO GEO. W. BERLIN, OF HARRISONBURG, VIRGINIA.

IMPROVEMENT IN PUMPS.

Specification forming part of Letters Patent No. 202,577, dated April 16, 1878; application filed
February 23, 1878.

To all whom it may concern:

Be it known that I, JOHN W. PALMER, of Port Republic, in the county of Rockingham, and in the State of Virginia, have invented certain new and useful Improvements in Pumps; and do hereby declare that the following is a full, clear, and exact description thereof, reference being had to the accompanying drawings, and to the letters of reference marked thereon, making a part of this specification.

The nature of my invention consists in the construction and arrangement of a pump for forcing water from deep and other wells up any desired height, as will be hereinafter more fully set forth.

In order to enable others skilled in the art to which my invention appertains to make and use the same, I will now proceed to describe its construction and operation, referring to the annexed drawings, in which—

Figure 1 is a central vertical section of my improved pump. Fig. 2 is a plan view of the same. Fig. 3 is a bottom view of the pump-cylinder, and Fig. 4 shows the hollow piston-rod made in sections.

A represents the well, with cover B, which forms the platform for operating the pump. C represents the pump-cylinder, open at the top, and provided in its bottom with a series of apertures, *a*, which are closed by a valve, D, on top, said valve having a stem, *b*, passing through and projecting below the bottom of the cylinder.

The cylinder C is secured upon a frame-work, E, which rests on the bottom of the well A, thus keeping the pump-cylinder elevated above the same.

G represents the piston or plunger, which is made hollow, with an interior valve, *d*. Around the outside of the piston is a circumferential groove, *e*, for the application of suitable packing, when required. From the top of the hollow piston leads a hollow or tubular piston-rod, F, which forms the discharge-pipe for the pump, and extends upward through the platform B. At a suitable distance above the platform the pipe or hollow rod F is provided with the spout H, and upon its upper end is screwed a cap, I, as shown.

Upon the platform B is erected a suitable frame-work, J, in bearings upon which are placed two shafts, *h* and *h'*. The shaft *h* is provided with a gear-wheel, K, which meshes with a pinion, *k*, on the shaft *h'*; and L is a lever or crank, which may be applied to the end of either shaft. The shaft *h* is further provided with a pinion, *m*, which meshes with a rack-bar, *n*, secured to the side of the discharge-pipe F. On the opposite side of this pipe from the rack-bar is a longitudinal rib or flange, *p*, which fits in a groove-pulley, *t*, secured upon the shaft *h'*, to guide and balance the piston and piston-rod.

When the crank L is applied to the shaft *h* the gears K *k* are, of course, not necessary; but I have applied them in position, so that when more power is required the crank can be changed to the shaft *h'*. In either position, by turning the same in one direction, the pinion *m*, acting upon the rack-bar *n*, will raise the piston by means of the hollow rod or pipe F, which movement of the piston draws the water into the cylinder below the piston. By now reversing the crank the piston is forced down, which causes the water to pass upward through the piston and rod and out at the spout.

It will be understood that, to force the water upward through the pipe in the manner described, I apply not only the force or power used to turn the crank, but the weight of the piston and entire pipe above it is added to such power, so that the water will easily pass up in a good stream.

It will readily be seen that I may add other sections of discharge-pipe, so as to bring water to the different stories of a building, in which case there will be a discharge-spout on each floor, and also duplicates of the mechanism for operating the pump on each story. The various discharge-spouts should then also be provided with stop-cocks, slides, or equivalent devices for closing all but the one through which the water is intended to come out for the time being.

The cap I should at all times be applied on the extreme upper end of the pipe F.

On the platform is pivoted a button, R, which, in the summer-time, is turned close

against the side of the pipe F, so as to form a stop for the lower end of the rack *n*. This stops the piston at such a distance above the bottom of the cylinder that the valve-stem *d'* therein will not come in contact with the lower valve, and hence the valve *d* will remain closed, and the water in the pipe cannot escape.

In the winter-time the button R is turned away, when the piston will descend far enough to raise the valve *d* and allow the water in the pipe F to escape, and thus prevent freezing.

If desired, weight may be added to the pipe or piston, or both, which, of course, will increase the force.

By making the cylinder and piston of suitable size, the piston and pipe may be raised to the top, and then allowed to descend by its own gravity alone, which would cause a continuous stream to flow from the discharge-spout, the duration of the same depending

upon the size of the different parts and the size of the discharge-orifice. In this way it would be applicable to dairies and other purposes.

Having thus fully described my invention, what I claim as new, and desire to secure by Letters Patent, is—

The combination of the discharge-pipe F, provided with the rack *n* and rib *p*, the shaft *h* with pinion *m*, the shaft *h'* with pulley *t*, the gears K *k*, and crank L, all substantially as and for the purposes herein set forth.

In testimony that I claim the foregoing I have hereunto set my hand this 23d day of February, 1878.

JOHN W. PALMER.

Witnesses:

FRANK GALT,
J. M. MASON.