

W. H. STEIN.
Washing-Machine.

No. 202,598.

Patented April 16, 1878.

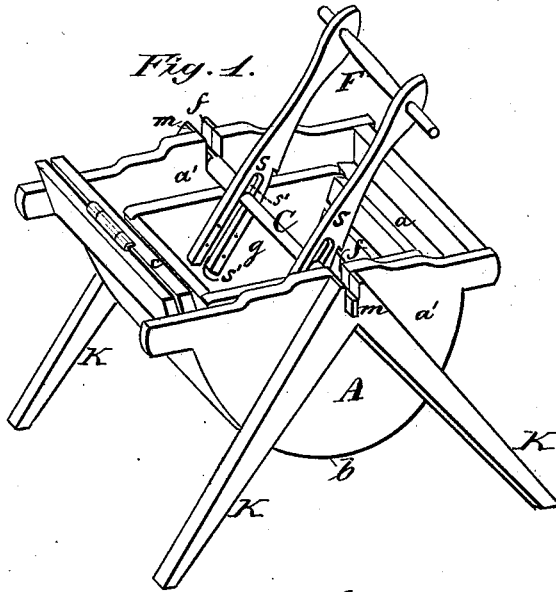

Fig. 2.

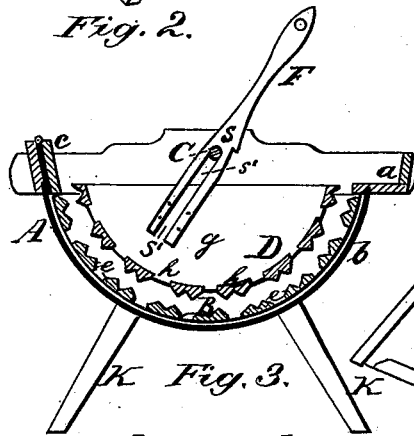

Fig. 5.

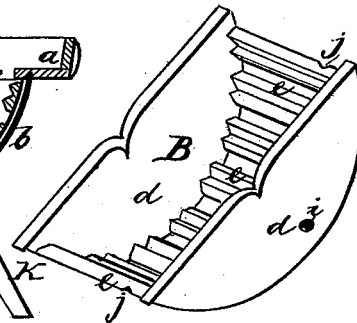
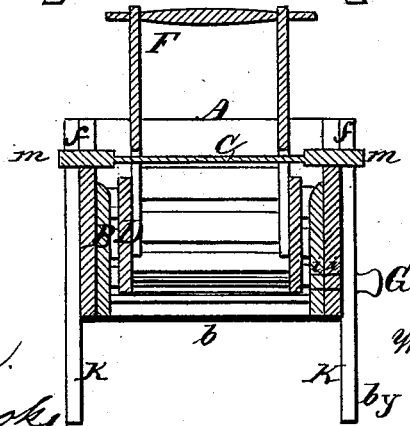
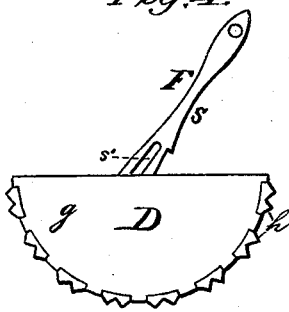

Fig. 4.



Attest:
August Petermann.
Jno. P. Brooks.

Inventor:
William H. Stein,
by Louis Baggett
attorneys.

UNITED STATES PATENT OFFICE.

WILLIAM H. STEIN, OF GARNETT, KANSAS..

IMPROVEMENT IN WASHING-MACHINES.

Specification forming part of Letters Patent No. 202,598, dated April 16, 1878; application filed July 3, 1877.

To all whom it may concern:

Be it known that I, WILLIAM H. STEIN, of Garnett, in the county of Anderson and State of Kansas, have invented certain new and useful Improvements in Washing-Machines; and I do hereby declare that the following is a full, clear, and exact description thereof, which will enable others skilled in the art to which it appertains to make and use the same, reference being had to the accompanying drawings, which form a part of this specification, and in which—

Figure 1 is a perspective view. Fig. 2 is a longitudinal vertical section. Fig. 3 is a cross-section. Fig. 4 is the reciprocating rubber detached; and Fig. 5 shows the stationary rubber detached.

Similar letters of reference indicate corresponding parts in all the figures.

This invention relates to that class of washing-machines in which the clothes are rubbed between two corrugated surfaces, one stationary and the other reciprocating; and it consists in the construction and arrangement of parts hereinafter more fully shown and described.

In the drawing, A is the box or tub, which is semi-cylindrical in shape, the bottom *b* being preferably made of galvanized sheet metal. One end of the tub has a ledge, *a*, and to the other opposite end is hinged a leaf, *c*. B is the stationary rubber. This consists of two side pieces, *d d*, fitting in box A against the sides thereof, and united by slats *e e*, the rubbing surface of which is grooved to the shape of an inverted W. One end of the stationary rubber, when in position, rests against the ledge *a*, while the leaf *c* is folded down against the other end, thus securing it firmly in position.

ff are deep vertical slots or recesses, made in the sides *a' a'* of the stationary tub A, to receive the flat ends or tenons *m m* of a shaft, C, which forms a stationary bearing for the handle-pieces *s s*, upon which the reciprocating rubber D is hung. This consists, like the stationary rubber B, of side pieces *g g*, united by W-grooved slats *h h*, facing the slats *e* of rubber B.

The handle-pieces *s s* are slotted at their lower ends, as shown at *s'*, their upper ends being united by a cross-piece, F, the side pieces *s s* straddling the stationary shaft C, as shown, and placed at a suitable inclination, relative to the rubbers, to bring the cross-piece F within easy and convenient reach of the operator.

The sides *d d* of the stationary rubber and the tub have perforations *i*, stopped by a plug, G, which may be removed for the purpose of drawing off the water, and the under side of slats *e* of rubber B is grooved, as shown at *j*, in order to prevent a portion of the dirty water from being retained in the box by slats *e*.

By the construction and combination of the reciprocating rubber D, with its handle *s s* F, and stationary shaft C, upon which it rides, as herein described, slots *s'* will permit the rubber to rise on the shaft and adjust itself to the quantity of clothes placed under it. Should the layer of clothes under the rubber exceed in thickness the length of slots *s'* above the side pieces *g g*, the deep slots or recesses *ff*, in which the tenons *m m* of shaft C rest, will enable the shaft itself to rise a certain distance; hence, a twofold adjustment of the reciprocating rubber D is possible, more than one of which (the first,) however, seldom comes into play.

Having thus described my invention, I claim and desire to secure by Letters Patent of the United States—

As an improvement in washing-machines, the combination of the reciprocating rubber D, having slotted handle-pieces *s s* permanently secured to its sides and riding loosely on shaft C, said shaft having flattened tenons *m m*; and tub A, having vertical slots *ff*, all constructed and combined to operate as described, for the purpose specified.

In testimony that I claim the foregoing as my own I have hereto affixed my signature in presence of two witnesses.

WILLIAM H. STEIN.

Witnesses:

HENRY YOUNG,
SILVESTER H. DODGE.