

W. H. WHITTLESEY & C. T. NOBLE.
Wheel-Plow.

No. 202,615.

Patented April 16, 1878.

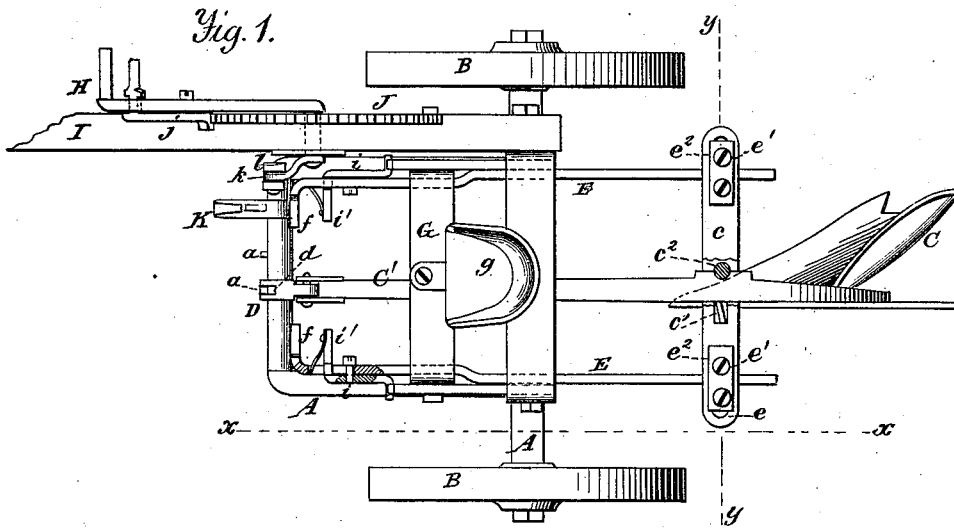

Fig. 4.

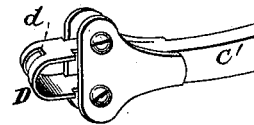
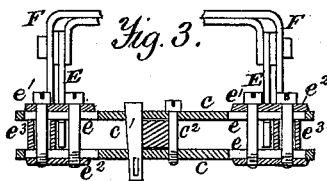
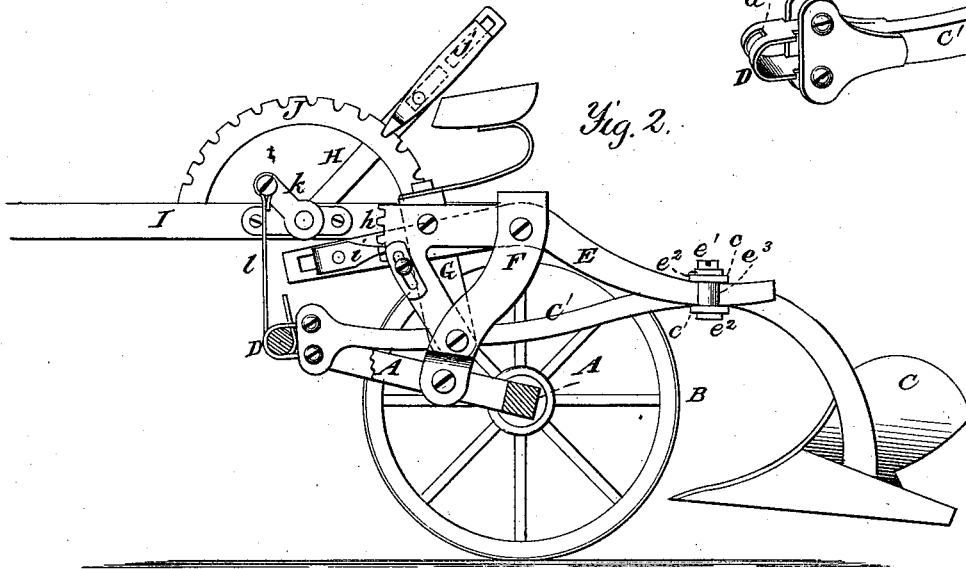

Fig. 2.



Witnesses:
A. Rippey,
James H. Sarge.

Inventors:
Wm. H. Whittlesey,
Charles T. Noble.

per
Edson Prot.
Attys

UNITED STATES PATENT OFFICE.

WILLIAM H. WHITTLESEY AND CHARLES T. NOBLE, OF RUSSELL, IOWA.

IMPROVEMENT IN WHEEL-PLOWS.

Specification forming part of Letters Patent No. 202,615, dated April 16, 1878; application filed January 16, 1878.

To all whom it may concern:

Be it known that we, WILLIAM H. WHITTLESEY and CHARLES T. NOBLE, of Russell, in the county of Lucas and State of Iowa, have invented certain new and useful Improvements in Wheel-Plows; and we do hereby declare that the following is a full, clear, and exact description thereof, which will enable others skilled in the art to which it appertains to make and use the same, reference being had to the accompanying drawings, and to letters of reference marked thereon, which form a part of this specification, and in which—

Figure 1 is a plan view of our improved wheel-plow. Fig. 2 is a vertical longitudinal section of the same on line *x x* of Fig. 1. Fig. 3 is a section on line *y y* of Fig. 1, and Fig. 4 is a detached perspective view of the plow-beam clevis.

Corresponding parts in the several figures are denoted by like letters.

This invention relates to certain improvements in wheel-plows; and it consists in the combination, with independent foot-levers and plow-beam, of a transverse slotted plate or other equivalent mechanism, to attach the free rear ends of said levers to the plow-beam and allow the latter to slide thereon, whereby the plow-beam may have free longitudinal movement when being raised, and the plow may be leveled, and of certain other details of construction, substantially as hereinafter more particularly set forth.

In the annexed drawing, A marks an axle, extended forward, as shown, and having wheels B B. C refers to the plow, and C' to its beam, which is connected to the axle A by means of the clevis D. The clevis D embraces the axle, and is provided with a vertical slot, *d*, which receives one or more projections or studs, *a*, upon the axle, to retain the clevis at the desired point or points thereon in adjusting the beam or beams horizontally. The clevis may be shifted from the said projections or studs to points upon the axle between said projections, and the same end be attained.

To the beam C' are attached transverse parallel plates *e e* by means of key *e'* and bolt *e''* passing through said plates upon either side of the said beam. These plates are provided near

their ends with slots *e e*, which receive parallel posts or bolts *e'* *e'*, held apart or connected together external to said plates by means of short plates or bars *e'' e''*. The posts or bolts *e'* *e'* may be inclosed within the plates by means of tubes or sleeves *e''' e'''*. The slots *e e* in the plates *e e* permit of lateral movement of the plow or plows. E E refer to two foot-levers, fulcrumed in the uprights or frame F F, secured to the axle A, and pass through the parallel uprights of a second frame, fastened to the said axle. The rear ends of the levers E E are confined to the plates *e e* between the inclosed posts or bolts *e'* *e'*. Their forward ends are provided with right-angled projections *f f*, for the feet of the driver, seated upon the seat *g*, mounted upon frame G, to rest on.

It will be observed that by exerting downward pressure upon the levers E E they will elevate the plow or plows and lift them out of the ground, in which position they will be held by the engagement, with teeth or racks secured to the seat-supporting frame G, of spring pawls or detents *i i*, adjusted to the forward ends of said levers. The pawls or detents *i i* are provided with right-angled projections *i' i'*, which are so arranged that they can be operated by the foot or heel of the driver, to retract or disengage the pawls from their racks, and thus free the levers and allow the plows to re-enter the ground. By pressing upon the right foot-lever the plow is presented with its land-side toward the ground. By pressing upon the left foot-lever the plow is presented with its mold-board toward the ground.

H is a hand-lever, fulcrumed to the tongue I of the plow, and alongside of a toothed segment, J, fastened to the tongue. The lever H is provided with a pawl, *j*, which engages the segment J. The fulcrum of the lever H is provided upon the opposite side of the tongue I, through which it passes, with a right-angled arm, *k*, which is connected to the forward end of the axle A by a strap or connecting-piece *l*. By means of this mechanism the angle of presentation of the point of the plow or plows to the ground can be varied.

K is an S-shaped clevis, keyed to the axle A, for the attachment of a second or third horse to the plow.

Having thus described our invention, what we claim, and desire to secure by Letters Patent, is—

1. The combination, with the independent foot-levers *E E* and plow-beam *C'*, of the transverse slotted plates *c c*, or other equivalent mechanism, to attach the free rear ends of said levers to the plow-beam and allow the latter to slide thereon, whereby the plow-beam may have free longitudinal movement when being raised, and the plow may be leveled, substantially as shown and described.

2. The foot-levers *E*, provided with spring-

pawls and ratchets *i i h*, in combination with the parallel plates *c c*, between which slide the free rear ends of the levers *E E* and plow-beam *C'*, substantially as and for the purpose set forth.

In testimony that we claim the foregoing as our own we hereunto affix our signatures in presence of two witnesses.

WILLIAM H. WHITTLESEY.

CHARLES T. NOBLE.

Witnesses:

WM. IRVINE,

JAMES A. SEARS.