

J. A. WOODMANSEE.
Car-Coupling.

No. 202,622.

Patented April 16, 1878.

Fig. 1.

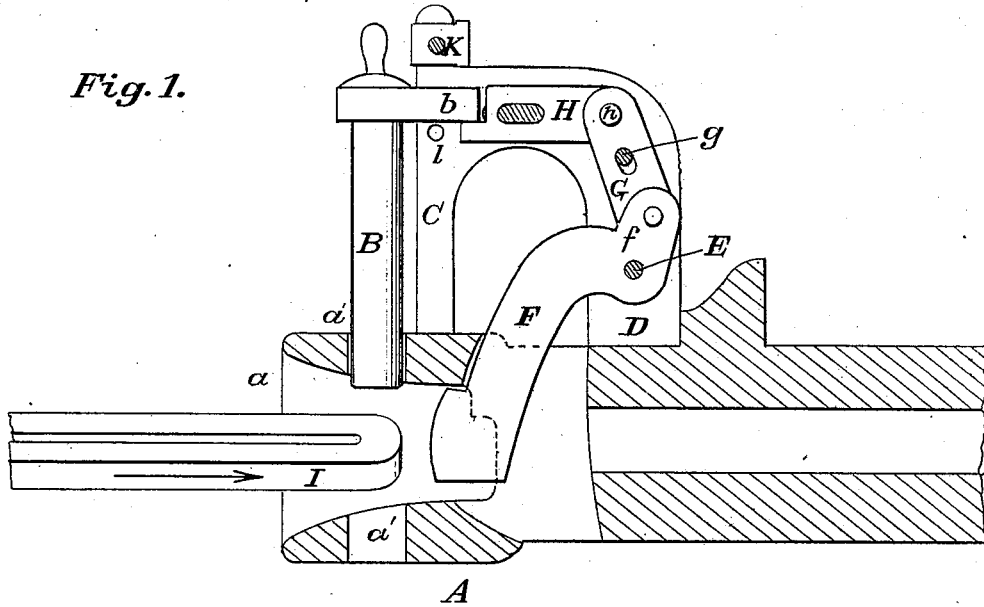
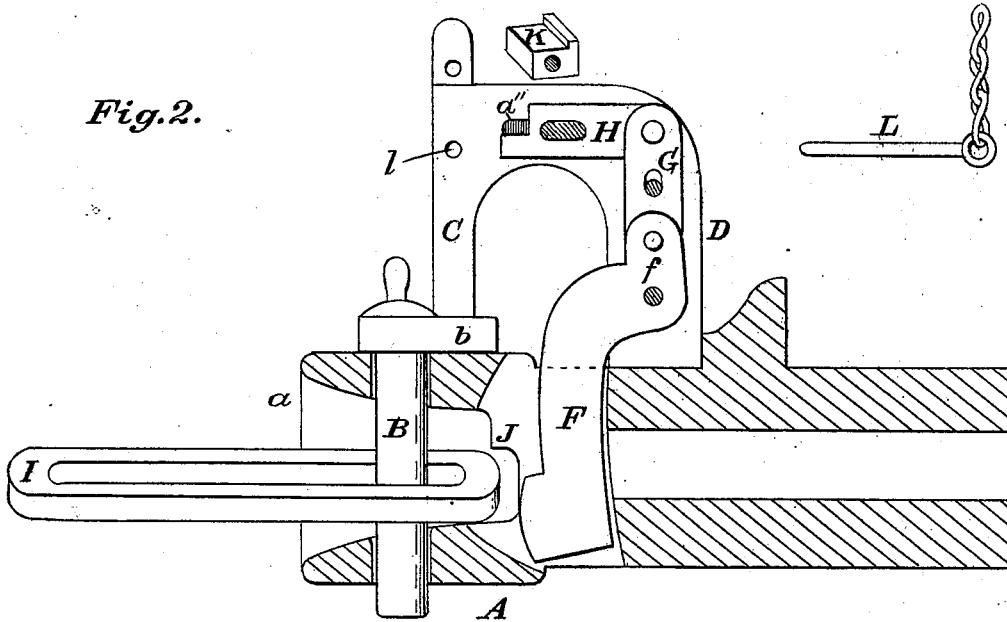

Fig. 2.



Attest
Horace E. Johnson
S. Bond

Inventor:—
J. A. Woodmansee
By Knight Bros.
Attys.

J. A. WOODMANSEE.
Car-Coupling.

No. 202,622.

Patented April 16, 1878.

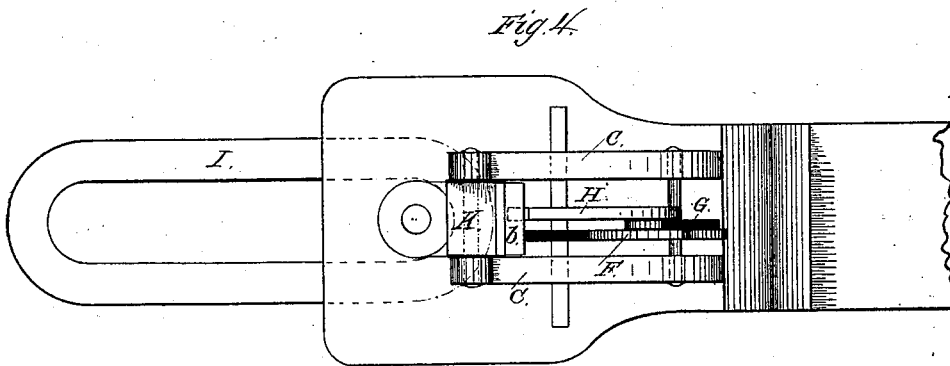
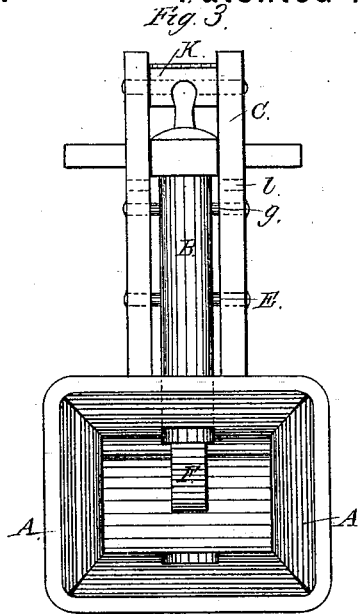

Attest
Horace E. Johnson
L. A. Bond

Inventor
J. A. Woodmansee
By Knight Bros.
Atty.

UNITED STATES PATENT OFFICE.

JOSEPH A. WOODMANSEE, OF NEW VIENNA, OHIO.

IMPROVEMENT IN CAR-COUPPLINGS.

Specification forming part of Letters Patent No. **202,622**, dated April 16, 1878; application filed July 27, 1876.

To all whom it may concern:

Be it known that I, JOSEPH A. WOODMANSEE, of New Vienna, Clinton county, Ohio, have invented an Improved Car-Coupling, of which the following is a specification:

Figures 1 and 2 are vertical longitudinal sections of a coupling embodying my invention in the opened and closed conditions, respectively. Fig. 3 is an end view. Fig. 4 is a top view.

A represents the draw-head, having the customary mouth or muzzle *a*, to receive the link, and vertical hole *a'*, for the coupling pin or bolt B. The coupling-bolt B has a T-head, *b*, which travels up and down in guides C.

A standard, D, which rises from the head A, affords journal-bearings E for trigger F, whose counter-arm *f* constitutes the lower member of a toggle, *f* G, whose upper member, G, is pivoted to the standard at *g*, and to a sliding catch, H, at *h*, which catch plays in a horizontal slot, *a''*, in the top of the head.

Accidental escape of the bolt B from the head is prevented by a block, K, whose removal enables the bolt to be unshipped when necessary.

A pin, L, inserted in a hole, *l*, in the guides, serves to hold the bolt B to its elevated

position independently of the trigger, when desired.

The operation is as follows: The draw-head is set to receive the link I of the opposing car by elevating the bolt B and engaging the catch H under the bolt-head, as in Fig. 1. This action advances the lower end of the trigger F, as seen in said figure. The link I, now approaching, pushes back the lower end of trigger F. This action straightens the toggle *f* G, and retracts the catch H, so as to liberate the bolt B, and to permit it to drop into and lock the link, as in Fig. 2.

The inner extremity of the locked link being held down by the shoulder or projection J of the interior of the head, the link is thereby held in a horizontal position, adapted to readily engage with the muzzle of an opposing car.

I claim as new and of my invention—

The coupling herein described, consisting of T-headed bolt B *b*, standard D, guides C C, catch H, toggle G *f*, and trigger F.

In testimony of which invention I hereunto set my hand.

JOSEPH A. WOODMANSEE.

Attest:

GEO. H. KNIGHT,
HORACE E. JOHNSON.