

A. ALGEO.
Hat-Pressing Machine.
No. 202,623.
Patented April 23, 1878.

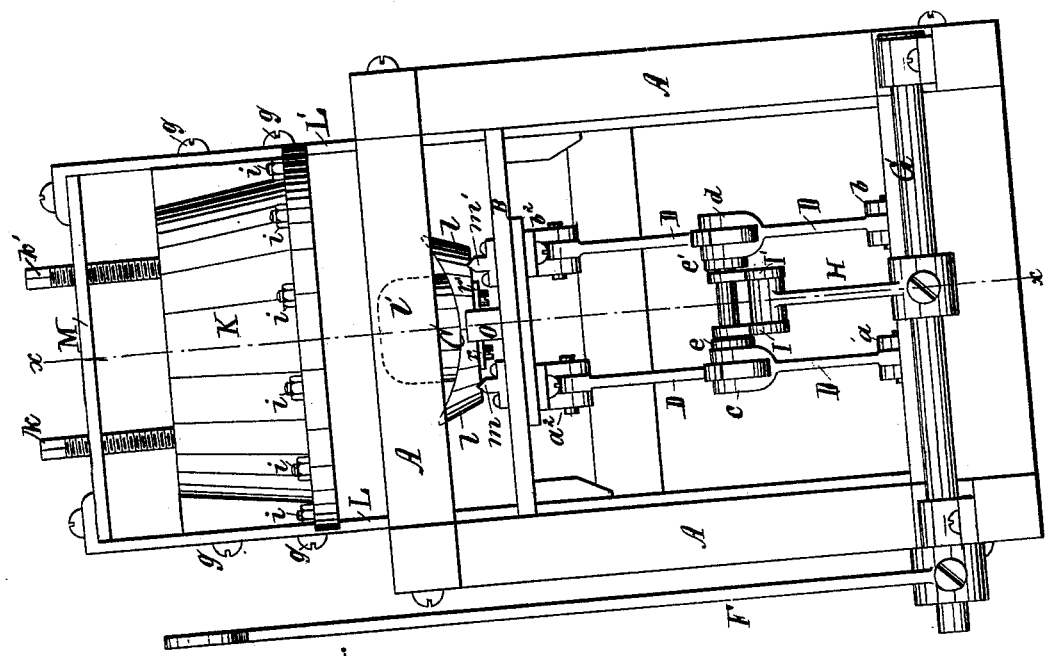
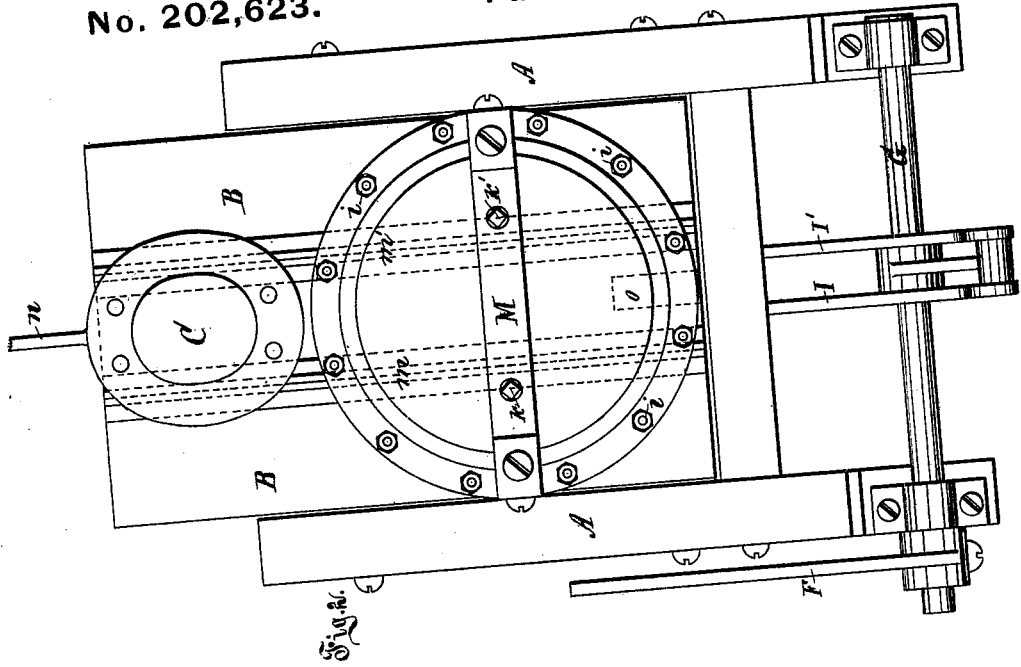

Witnesses:
Theodore B. Hooster
B. B. Curtis

Inventor:
Alexander Algeo
 By *J. H. DeLoach*
his atty.

A. ALGEO.
Hat-Pressing Machine.
No. 202,623.
Patented April 23, 1878.

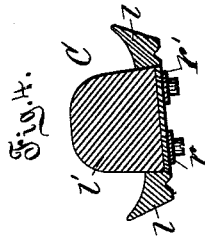
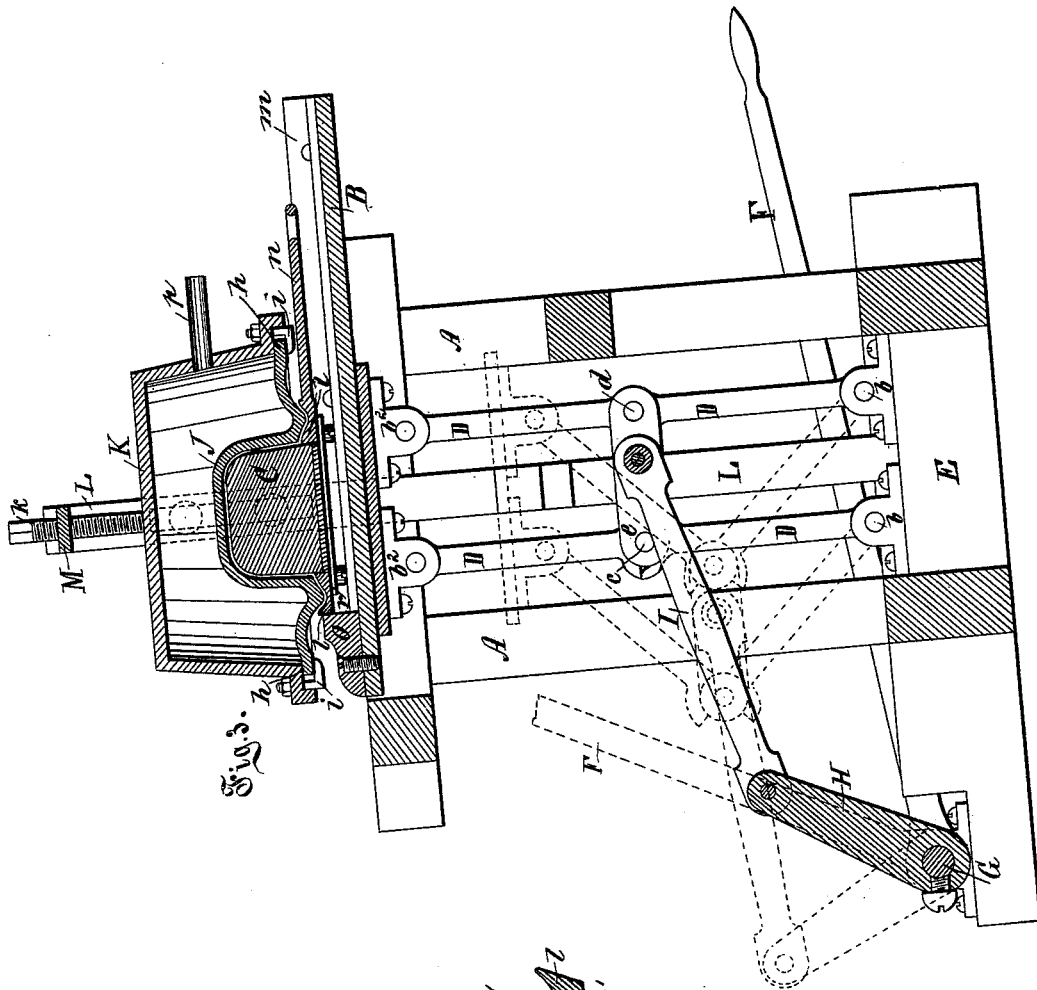

Witnesses:

Theodore. Weston.
C. S. Clark

Inventor:

Alexander Algeo
By J. P. Hatch
his atty.

UNITED STATES PATENT OFFICE.

ALEXANDER ALGEO, OF NEW YORK, N. Y.

IMPROVEMENT IN HAT-PRESSING MACHINES.

Specification forming part of Letters Patent No. 202,623, dated April 23, 1878; application filed March 12, 1878.

To all whom it may concern:

Be it known that I, ALEXANDER ALGEO, of the city of New York, county and State of New York, have invented a new and useful Improvement in a Machine for Pressing Hats, of which the following is a specification, reference being had to the accompanying drawings, forming part of the same.

Figure 1 is an end elevation of a machine containing my invention. Fig. 2 is a plan of the same. Fig. 3 is a vertical section of same on line *xx* of Fig. 1, and Fig. 4 is a vertical central section of the male die used in pressing hats.

This invention relates to a machine for pressing hats; and consists, first, in the peculiar construction and arrangement of the lower die with the movable bed of the press, permitting the said die to have a lateral movement on said bed, whereby it may be withdrawn from under the upper die for the convenient placing upon it of the hat to be pressed, and then be readily replaced under said upper die in position for pressing; second, in the combination, with the movable bed of the press, of four toggle-joint levers for moving said bed, operated by one and the same hand-lever, as particularly hereinafter described.

A is the frame upon which the working parts of my machine are mounted. B is a movable platform or bed which carries the lower or male die C, and is fitted to reciprocate vertically within the said frame. It is actuated by four toggle-joint levers, D D, pivoted at *a a b b* at the lower ends on cross-beams E of the frame, and at the upper ends at *a² a² b² b²* on the under side of the said bed B. This arrangement gives four bearing-points of the bed B upon these levers, separated some distance from each other, so that the bed requires no other guides or means of holding it level and in horizontal adjustment to the die J. These are connected together at the toggle-joints *c d* by the connecting-links *e e'*, and are actuated by the hand-lever F, the rock-shaft G, the arm H, and the connecting-bars I I'.

J is the upper or female die, which is covered by a steam chest or box, K, the said die and chest being secured together with a steam-tight joint at *h*, Fig. 3, by means of screw-

hooks, *i*. This die and steam-chest are supported on strong iron uprights L L', extending from the bottom sills of the frame to a cross-bar, M, over the box J, slotted openings being made in said uprights, through which screws *g* pass into screw-holes in the body of the steam-chest.

k k' are set-screws working in screw-holes in the cross-bar M, their lower ends resting against the said steam-chest. By means of the screws *g'* and these set-screws the die C is made adjustable vertically. This female die J may be made of cast metal, and with the proper form for the hat designed to be pressed.

The lower or male die C may also be formed of metal, or, if preferred, of some material that will remain plastic long enough to have form given to it by pressing it into the upper die J and then become sufficiently hard to perform its office of pressing hats.

I preferably construct this die by making a metal annular plate or rim, *l*, the upper face of which is formed to give the required shape to the rim of the hat, the opening in this annular plate being formed to receive the crown *l'* of the die designed to press the crown of the hat, being made separate and introduced into the annular plate from below upward, the inner edge of the plate and the crown *l'* of the die being formed a little tapering and accurately, fitted to the opening in the rim so that the crown can just go into its place, but not pass through. Then it is held in place by straps or bars, *r r'*, across the base of the crown screwed to the under face of the annular plate *l*.

The upper face of the bed or platform B is provided with ways *m m'*, upon which the die C may slide, grooves being cut in the under face of the said die to fit onto the said rails. For convenience, the said die is provided with a handle, *n*, and *o* is a stop to limit the movement of the said die when it is pushed under the upper die J, so as to adjust it thereto.

p is a steam-pipe leading into the steam-chest K, the design being to heat the die J.

When the bed B is dropped down into the position indicated by the positions of the levers, as shown in dotted lines in Fig. 3, the die C may be withdrawn from under the die J, by the operator grasping the handle *n* and

pulling the said die C along on the rails *m m'* to the front of the machine, when a hat to be pressed may be conveniently placed in the said die, which may then be readily pushed back to its place against the stop *o* immediately under the die J, in position for the operation of pressing, by depressing the lever F.

What I claim as my invention, and desire to secure by Letters Patent, is—

1. The combination, in a hat-pressing machine, of the movable platform or bed B, provided with ways *m m'* and stop *o*, the die C, provided with grooves fitting onto said ways, and the die J, all constructed and arranged to operate as and for the purpose described.

2. The combination, in a hat-pressing machine, of the dies J and C, the movable plat-

form or bed B, the four toggle-joint levers to be actuated by one and the same hand-lever F, rock-shaft G, arm H, connecting-bars I I', and the connecting-links *e e'*, all constructed and arranged to operate as and for the purpose described.

3. The male die C, composed of the rim or annulus *l*, the crown *i*, and the bars *r r'*, constructed and combined to operate as and for the purpose described.

Witness my hand this 9th day of March, 1878.

ALEXANDER ALGEO.

Witnesses:

B. S. CLARK,

M. F. CLIFTON.