

R. W. MORRELL, & T. & J. PARKINSON.
Sewing-Machine.

No. 202.857.

Patented April 23, 1878.

FIG. 3.

FIG. 2.

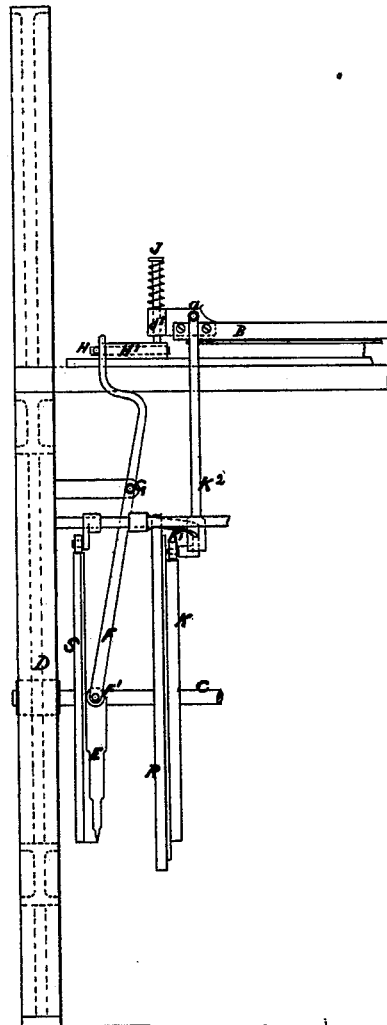
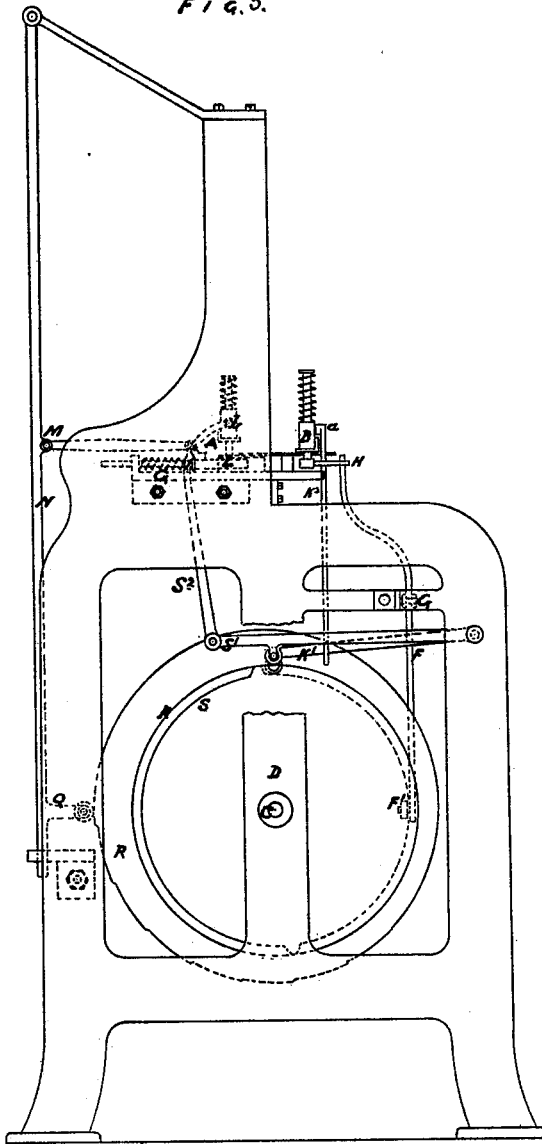

Witnessed.
Aluminum
Olava Broughton

Robert W. Morrell,
 Thos Parkinson,
 Joseph Parkinson
 Inventors
 By Atty.
John C. Earl

R. W. MORRELL, & T. & J. PARKINSON.
Sewing-Machine.

No. 202,857.

Patented April 23, 1878.

FIG. 2.

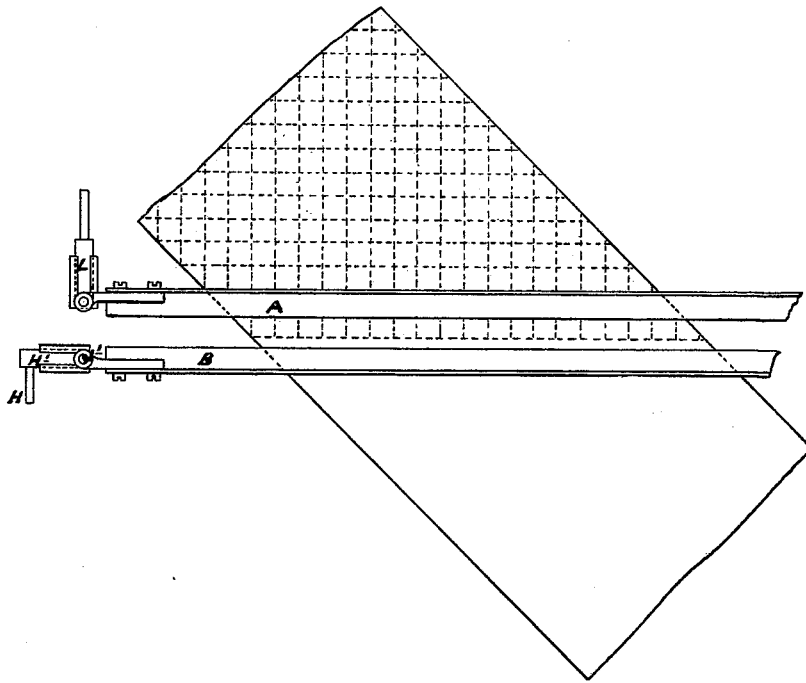

Witnesses:
J. H. Chumney
Clara Broughton.

Robert W. Morrell
Thos. Parkinson
Joseph Parkinson
 Inventors
 By atty. *Wm. E. Hall*

UNITED STATES PATENT OFFICE.

ROBERT W. MORRELL, THOMAS PARKINSON, AND JOSEPH PARKINSON, OF
BRADFORD, ENGLAND.

IMPROVEMENT IN SEWING-MACHINES.

Specification forming part of Letters Patent No. **202,857**, dated April 23, 1878; application filed
July 1, 1876; patented in England, July 9, 1874.

To all whom it may concern:

Be it known that we, ROBERT WILSON MORRELL, THOMAS PARKINSON, and JOSEPH PARKINSON, all of Bradford, in the county of York, Kingdom of England, have invented certain Improvements in Sewing-Machines, of which the following is a specification:

This invention relates to an improved means and apparatus for imparting to the forward feed-bar and to the lateral or sidewise feed-bar the required movements whereby the material being sewed or operated upon is fed to and brought under and held in proper position for the needles.

We mount on a shaft supported by the end frames of the machine cam-tappets or step-wheels, one at each end of the machine. Levers having fulcrums about midway their length are provided at their lower ends with runners or anti-friction bowls, which rest or bear on the tappet-wheels. The other end of one of the said levers engages with a pin in a slide-block, to which block and to a like slide-piece at the other end of the machine the feed-bar for giving the lateral or sidewise feed is mounted.

On rotation being imparted to the tappet-shaft, each succeeding "lift" or step on the tappet will remove the lever last referred to on its fulcrum, causing its upper end to act on the pin and slide-piece, so moving the feed step by step until the desired lateral traverse has been given, whereon other tappets on the tappet-shaft will act on levers, lifting or raising the feed-bar clear of or above the work. Other cam-tappets will now act on runners or anti-friction bowls attached to the lower ends of pendent levers, moving them outward on their fulcrums. About midway the length of the pendent bars are hinged and adjustable links. These links are connected with two slide-pieces, which support and carry the forward or front feed-bar, which will be moved step by step forward as each throw or lift of the tappet-plate acts on the pendent levers.

During the period or time the forward feed is in operation the lateral feed-bar will be inoperative, by reason of the runners of its levers moving over a plain part of their cams, and so will the forward feed-bar remain inop-

erative from a like cause when the lateral feed-bar is in operation, the feed-bars being returned to their original position by means of tappets or springs.

In order that this invention may be fully understood, we herein give reference to accompany sheets of drawings of a machine with our improvements applied thereto.

Figure 1 is an end elevation; Fig. 2, a side elevation, and Fig. 3 the same end view, with a different form of lever.

A is the feed-bar for giving the forward motion to the material under operation, and B is the lateral or sidewise feed-bar. C is a shaft, which is mounted in the end frames D of the machine. E is a cam or step wheel, which acts on the friction-bowl F' of the lever F, which lever is hinged at G, and the top end of the said lever bears against a pin, H, in the slide H', to which slide the feed-bar B is attached by means of the pin J passing through the piece J' on the end of the feed-bar. The drawing shows the bar just at the point of commencing the lateral feed. By the time the cam E has performed half a revolution the lateral feed will be completed, whereon the cam K, acting on the levers K¹ and K², the latter of which is attached to the feed-bar at a, will raise the said bar clear of or above the work, and the forward feed-bar A is next put into operation. This feed-bar is mounted, similarly to the feed-bar B, in slides L, which slide-pieces are connected, by links M, to the levers N, at the lower end of which are anti-friction bowls Q, bearing against cams R. As these cams rotate the feed-bar is moved step by step, and by the time that they have performed half a revolution the feed-bar B will have completed its travel in the required direction. It is then raised above the work by cams S acting on levers S¹ and S², the latter being connected to the feed-bar at b. The return motion of both feed-bars is effected by springs. Those for the forward feed-bar A are shown at c, the spring for actuating the feed-bar B being attached to the lever F at the other end of the machine.

It has not been thought necessary to illustrate both ends of the machine, on account of the similarity of the mechanism.

Instead of the arrangement of levers shown

in Fig. 1 for effecting the forward feed, that shown at Fig. 3 may be adopted.

In the accompanying drawings, the slides and slide-boxes L and H are shown at right angles, whereby the stitches produced by the two feeds are likewise at right angles.

It will, however, be readily seen that by altering the angle of the slides the figures produced by the stitches may be varied; also, by making the grooves in the slides curved, a similar pattern will be produced on the material under operation.

By referring to Fig. 4 it will be seen that the material is inserted in the machine at an angle of forty-five degrees. By first moving the material laterally and then forward, the diamond pattern is produced. It will be seen that if the material were not inserted at this angle the lateral feed would in time draw the material to one side of the machine, and farther progress would be impossible.

Having thus described the nature of our

said invention, and shown by drawings how the same is to be or may be performed or carried into practice, we would have it understood that we do not confine ourselves to the precise details herein set forth, as the same may be modified.

We do not, however, wish it to be understood that we broadly claim a combined lateral and transverse feed for sewing-machines, as such is not new; but

What we claim as our invention, and believe to be new, is—

The combination of the two feed-bars A B, slides L and H', step-cams E and R, and cam S, with their levers and connections, substantially as described.

ROBERT WILSON MORRELL.

THOMAS PARKINSON.

JOSEPH PARKINSON.

Witnesses:

J. W. TASKER,

WALTER SCOTT.