

J. E. ATWOOD.
Machine for Straightening Shafting.

No. 202,978.

Patented April 30, 1878.

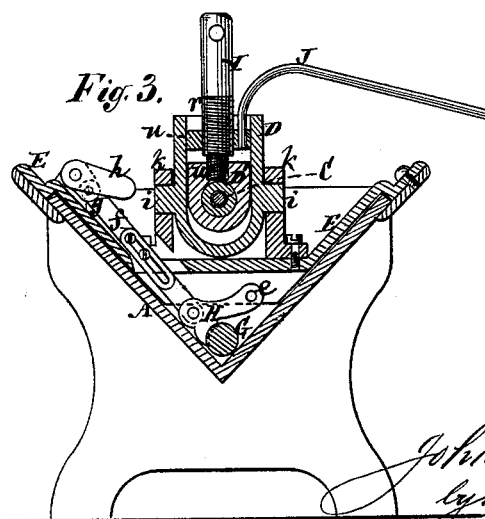
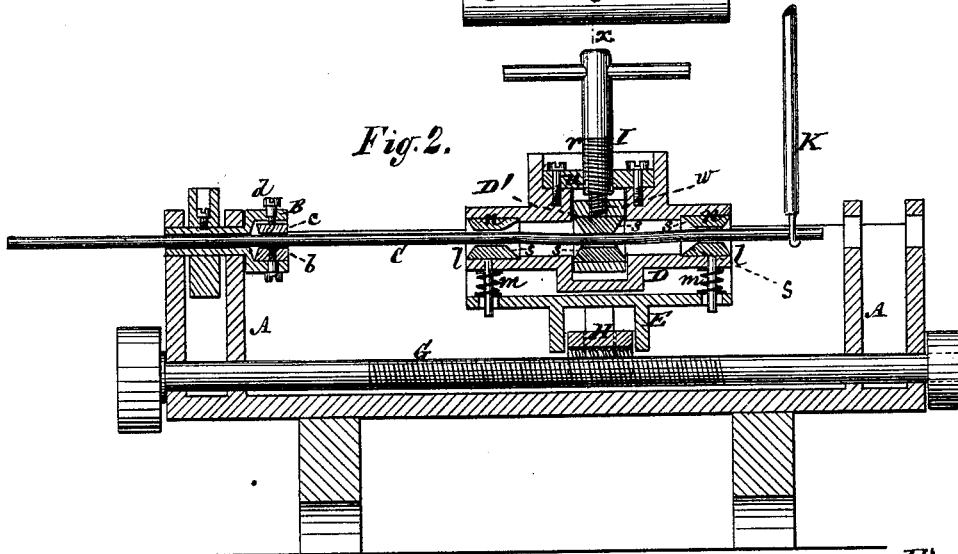
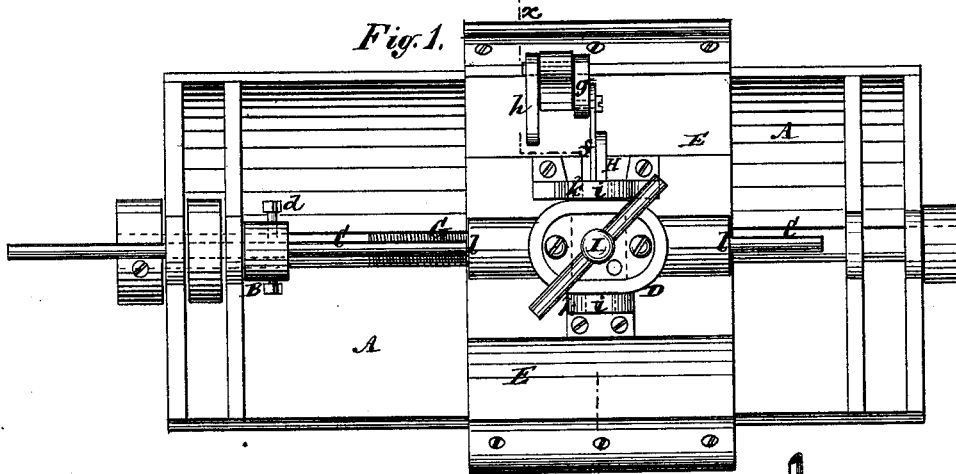

Witnesses:
Henry Eichling
Frank Haynes

Inventor:
J. E. Atwood
By his Attorneys
Brown & Allen

UNITED STATES PATENT OFFICE.

JOHN E. ATWOOD, OF STONINGTON, CONNECTICUT.

IMPROVEMENT IN MACHINES FOR STRAIGHTENING SHAFTING.

Specification forming part of Letters Patent No. **202,978**, dated April 30, 1878; application filed March 12, 1878.

To all whom it may concern:

Be it known that I, JOHN E. ATWOOD, of Stonington, in the county of New London and State of Connecticut, have invented certain new and useful Improvements in Machines for Straightening Shafting, of which the following is a description, reference being had to the accompanying drawing, forming part of this specification.

This invention relates to machines for straightening shafting, in which a straightener carried by a sliding carriage is run over or along the shaft to be straightened, to perform its necessary work of straightening a shaft much after the same manner as wire is now straightened; and the invention consists in various novel constructions and combinations of devices, including a rotating chuck for holding the shaft while being straightened, whereby increased efficiency and conveniences are obtained in the application and operation of the machine.

In the accompanying drawing, Figure 1 represents a plan of a machine constructed in accordance with my invention, and showing a shaft as in the course of being straightened by it. Fig. 2 is a central longitudinal vertical section of the same, and Fig. 3 a transverse vertical section thereof on the line *x x*. Fig. 4 is a face view of a rotating chuck, with dies therein, for holding the shaft at a given point in its length.

A is a longitudinal trough, forming the bed of the machine. On one end of this bed, or it may be at both ends, as hereinafter described, is a chuck, B, driven by belt or otherwise, and serving to rotate and hold at or near its one end, or at any given point in its length, the shaft C to be straightened.

D is the straightener, carried by a carriage, E, which is fitted to slide along the bed A, and when straightening the shaft is moved toward the chuck over or along the shaft, to straighten one part or a given length of the latter. In practice there is another like chuck at the opposite end of the bed A, in which the shaft to be straightened is again secured at another point in its length after the carriage, with its attached straightener, has been disconnected from the means which operate it, and has been moved by hand to the end of

the bed farthest from said chuck, and said carriage, with its straightener thus applied to the shaft, is subsequently operated in a reverse direction, to pass the straightener over the remaining portion of the shaft to complete the straightening of it. A single chuck, B, however, at one end of the bed, as shown in the drawing, will answer, and be sufficient to explain the invention.

The shaft C, which is projected through the chuck B, is centered and secured therein by means of dies *b c*, with which said chuck is fitted. One of these dies, *b*, is of a size to snugly fit the hole in the chuck, and is secured thereto, in a detachable manner, on one side of the chuck, while the other die, *c*, is of a less size than the hole in the chuck, and is adjustable radially therein by means of a screw, *d*. This provides for a true or central running of the shaft relatively with the chuck.

The carriage E is operated along the bed A by a rotating screw, G, in the bottom of the bed when the straightener D is run along the shaft to straighten it, and is moved back by hand when required to readjust the position of the straightener relatively to the chuck by unshipping the carriage from the screw, to which end the following simple means are provided: H is a threaded half-jaw, pivoted to the carriage at *e*, and serving, when pressed toward the screw G, to engage with the latter, and so propel the carriage by the rotation of the screw. Said jaw is connected at its outer or upper end, by a slide or sliding studs, with a slotted rod, *f*, which is carried by a crank, *g*, having its bearings in a projection within the bed on its one side, and is controlled by a handle or lever, *h*, to throw and hold the threaded half-jaw H in or out of gear with the screw, according to the end of the slot in the rod *f* which is brought, by the position of the crank *g*, up or down into contact with the half-jaw H to raise or depress it.

This straightener D is supported transversely to the longitudinal axis of the shaft under operation by trunnions *i i* in bearings *k k* on the carriage, whereby said straightener accommodates itself to deflection or vibratory motion of the shaft; but to hold the straightener in a concentric position at the ends *l l* of its tubular portion, through which the shaft

C passes to provide for the ready entry of the shaft, said ends are supported by springs *m m*. The ends *l l* of the straightener are fitted with bushes *n n*, having their opposite ends made flaring or inclined to facilitate the entry of the shaft and gradual release of it.

Within the straightener D, and forming part of it, is a sliding tubular presser, D', through which the shaft C passes, and which is also bell-mouthed or formed with inclines at both of its ends, for a like purpose or purposes as the bell-mouths of the bushes *n n*.

The longitudinally-traveling presser D' is adjusted up or down by a hand-screw, I, to give any required pressure on the shaft for the purpose of straightening the latter, as said presser is moved over or along it, and also for the purpose, by the gradual release of said presser, of preventing a crook being formed in the shaft, as would be the case were the presser to be released suddenly when leaving the shaft. The flaring or bell-mouthed extremities *s* of the bushes *n* and tubular presser D' also prevent a kink being formed in the end of the shaft when the latter leaves said bushes or bearings, and constitute automatic means for avoiding a kink or crook in the shaft at such part, and which cannot be avoided if the shaft be permitted to leave said bearings abruptly. Such automatic means insure the shaft leaving said bearings without a kink or crook in it should the operator neglect to release the screw.

J is a hose or pipe, which serves to pass a stream of water or other liquid to the shaft under operation by the presser, for the purpose of lubricating the shaft, and keeping it cool during the process of straightening.

The screw I has right and left hand threads *r w* on it, one of which works within a fixed

box or nut, *u*, and the other within the presser D', whereby a rapid and accurate adjustment of the presser may be obtained.

K is an elastic strap or connection, attached to any suitable fixed point overhead, and provided with a hook or hoop at its lower end, for supporting the free end or portion of the shaft without straining the latter while undergoing the process of straightening.

I claim—

1. The combination, with a longitudinally-traveling straightener, of a rotating chuck, for holding and rotating the shaft as said straightener passes over or along it, substantially as specified.

2. The tubular straightener D, provided with side trunnions *i i*, in combination with the longitudinally-sliding carriage E, in which said straightener is freely supported by said trunnions in transverse relation with the direction in motion of the carriage, substantially as and for the purpose herein set forth.

3. The combination, with the tubular straightener D, supported by transverse trunnions *i i*, of one or more springs arranged to automatically adjust said straightener to a fixed or given level, essentially as specified.

4. The elastic supporting strap or connection K for the shaft, in combination with the longitudinally-traveling straightener D and the chuck B, substantially as specified.

5. The tubular presser D' and bushes *n* in the ends of the straightener, constructed with flaring or bell-mouthed extremities *s*, substantially as and for the purpose specified.

JOHN E. ATWOOD.

Witnesses:

EUGENE ATWOOD,
C. H. COWAN.