

J. W. COLLET.
Step-Box for Shaft or Spindle.

No. 202,997.

Patented April 30, 1878.

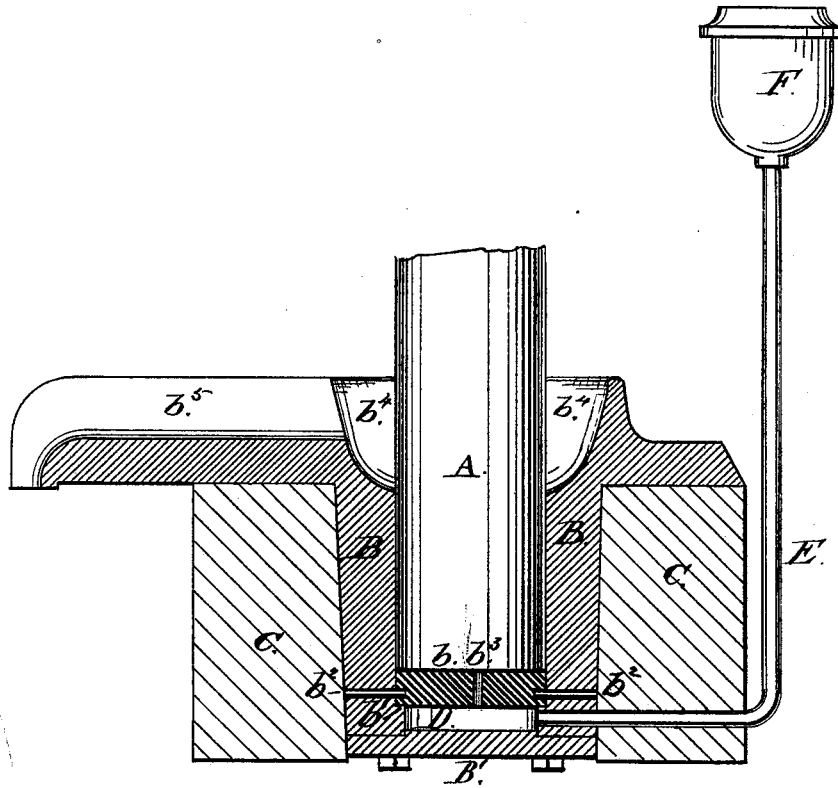

Attest:
Geo. H. Smith:
Chas. Hoock

Inventor:
John W. Collet
Byt Knight Bro.
Atty

UNITED STATES PATENT OFFICE.

JOHN W. COLLET, OF UPPER ALTON, ILLINOIS.

IMPROVEMENT IN STEP-BOXES FOR SHAFTS OR SPINDLES.

Specification forming part of Letters Patent No. 202,997, dated April 30, 1878; application filed November 22, 1877.

To all whom it may concern:

Be it known that I, JOHN W. COLLET, of Upper Alton, Madison county, Illinois, have invented a certain new and useful Improvement in Step-Boxes for Shafts or Spindles, of which the following is a full, clear, and exact description, reference being had to the accompanying drawings, making part of this specification.

My improvement relates to a device for lubricating the shaft in the step-box; and it consists in providing the flat bearing of the step-box with a hole eccentric thereto, for supplying oil to the shaft at a point aside from its center and within its circumference, an oil-chamber below the flat bearing communicating with said eccentric-hole, and being supplied with oil from an elevated cup or reservoir, the surplus oil entering an overflow-cup in the top of the box, from whence it flows off through a spout.

The drawing is an axial section of the box, showing the shaft, the oil-cup, and the oil-pipe in side view.

A is the lower end of a vertical shaft. B is the step-box, and C the bridge or bearing-bar in transverse section. *b* is a step-block, shown as dropped into the box, and sustained by shoulder *b*¹ and fixed by pins *b*². Beneath the block *b* is an oil-chamber, D, supplied with oil by an elevated cup, F, through a pipe, E. *b*³ is an oil-hole made through the block *b* at one side of the center.

The oil is forced upward into the step-box by capillary attraction, and by the pressure from that contained in the elevated cup F, and any surplus oil enters the annular cup *b*⁴, and runs off through the spout *b*⁵.

I am aware that a step-box has been made with an oil-hole beneath the center of the shaft, the shaft being made conical, so as to

cause a circulation of oil by centrifugal influence of the conical end of the shaft, and I do not claim to be the first inventor of this device.

In my improvement the center bearing is left intact, and the part of the shaft exposed to the oil-hole is carried around into contact with the bearing-surface of the box, so that it wears equally with the rest, and also carries the oil, by mechanical action, between the surfaces.

I do not rely upon centrifugal action to carry the oil forward, but also upon gravity and capillary attraction.

As one hole is made eccentric, the oil will cause indirect contact with the part of the lower end of the shaft that comes in direct contact with the face of the bearing-block, and consequently the introduction of oil between the surfaces is positive, and it will spread out over the whole of the bearing-surface by capillary attraction.

The chamber D allows any dirt that may be present in the oil to settle. This may be removed from time to time, if required, by removal of the plate B' at the bottom of the box.

The faster the shaft runs the faster the oil will feed, and when the shaft stops the feed will stop also.

I claim as my invention—

The step-box B, having the flat bearing *b*, provided with the oil-hole *b*³, eccentric thereto, for supplying oil to the shaft at a point aside from its center and within its circumference, oil-chamber D, and overflow-cup and spout *b*⁴ *b*⁵, substantially as set forth.

JOHN W. COLLET.

In presence of—

SAML. KNIGHT,
GEO. H. KNIGHT.