

M. FRANKENSTEIN.
Slate.

No. 203,026.

Patented April 30, 1878.

Fig. 1

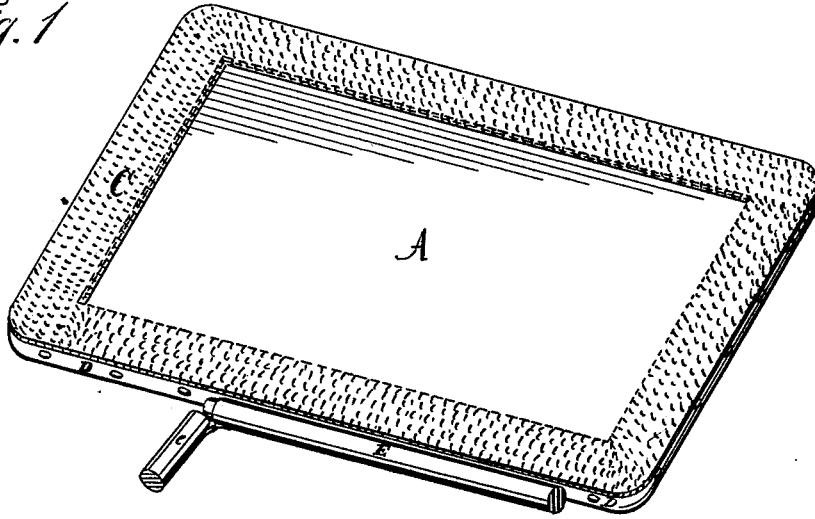
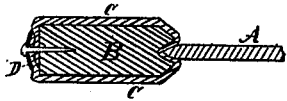

Fig. 2



Attest:
L. A. Seely.
R. T. Dyer.

Inventor:
Morris Frankenstein
by Geo. W. Dyer & Co
Atty.

UNITED STATES PATENT OFFICE.

MORIS FRANKENSTEIN, OF CHICAGO, ILLINOIS.

IMPROVEMENT IN SLATES.

Specification forming part of Letters Patent No. **203,026**, dated April 30, 1878; application filed February 21, 1878.

To all whom it may concern:

Be it known that I, MORIS FRANKENSTEIN, of Chicago, in the county of Cook and State of Illinois, have invented new and useful Improvements in School-Slates, as fully described in the following specification.

The nature of my invention relates to school-slates; and it consists, first, in covering the frame of the slate with a muffling material to render it noiseless, and in binding the frame together with a sheet-metal band to increase its strength; and, second, in combining with a slate constructed in the above manner a pencil-case, as will be more fully hereinafter explained.

In the drawing, Figure 1 represents a perspective view of a school-slate having my improvements. Fig. 2 represents a cross-section of the frame when covered entirely with fabric.

A is the slate, and B the wooden frame, both put together in the usual manner. C is the covering for the frame, of plush or other suitable fabric, which is placed over the stiles of the frame before the slate is inserted therein, its edges being lapped over the outward edges of the frame. D is a sheet-metal band, stretched around the edges of the slate-frame, and secured thereto by a series of tags driven through punch-holes in said band into the frame-stiles.

E is a pencil-case, having a hinged cover, *e*. This case is secured against the outward edge of one side of the frame B, either by tags or screws, or by soldering it to the metallic band D.

As will be noticed, my above-described improvements will not only make the school-slate perfectly noiseless while being handled, but will also strengthen the same to a great extent, while the pencil-case attachment will be of great convenience to the persons using the same.

What I claim as my invention is—

1. A school-slate the frame of which is covered with a muffling material, and is bound together by a band covering the entire edge of such frame, and secured thereto by tacks, substantially as described and shown.

2. In combination with a slate having its frame covered with a muffler, and bound together by a flat or concave band secured by tacks thereto, a pencil-case attached to such frame, substantially as and for the purpose set forth.

MORIS FRANKENSTEIN.

Witnesses:

WM. H. LOTZ,
EMIL H. FROMMANN.