

A. K. HERR.  
Tuyere.

No. 203,041.

Patented April 30, 1878.

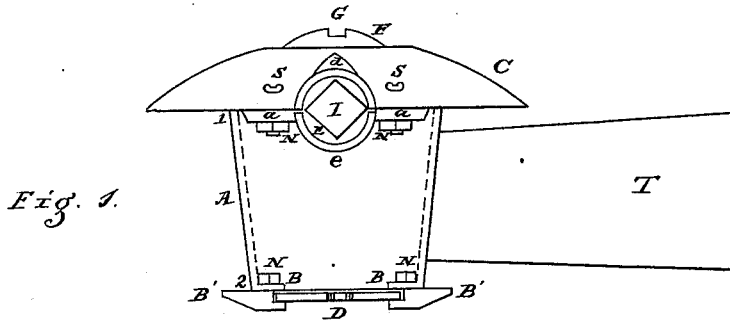

Fig. 1.

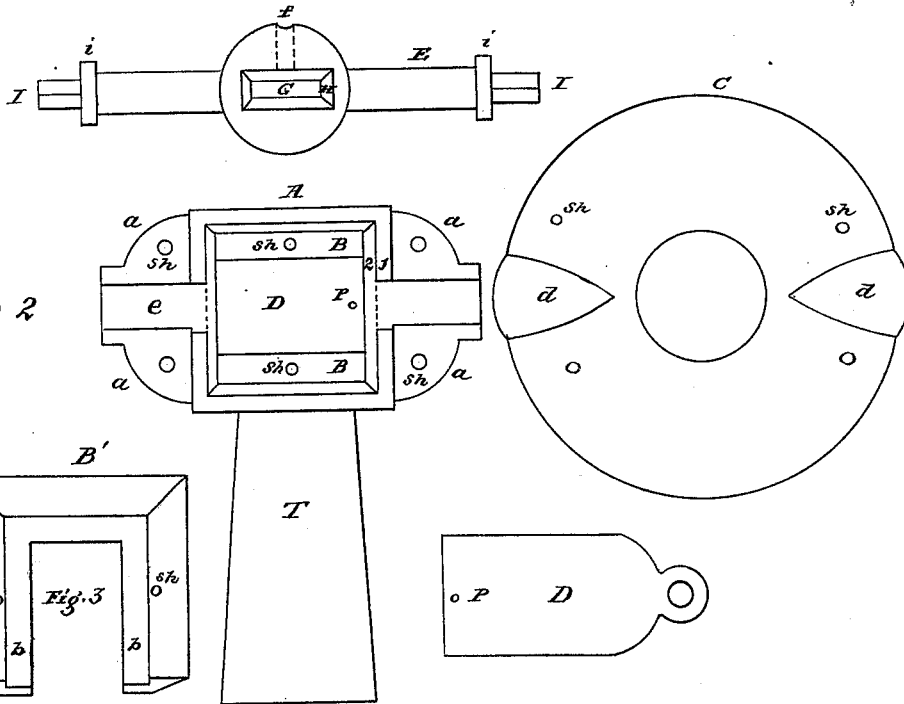

Fig. 2

*H. L. Book*  
*Jacob Stauffer*

*Abraham K. Herr.*

WITNESSES:

INVENTOR

ATTORNEY

# UNITED STATES PATENT OFFICE.

ABRAHAM K. HERR, OF LAMPETER, PENNSYLVANIA.

## IMPROVEMENT IN TUYERES.

Specification forming part of Letters Patent No. 203,041, dated April 30, 1878; application filed February 25, 1878.

*To all whom it may concern:*

Be it known that I, ABRAHAM K. HERR, of Lampeter P. O., in the county of Lancaster and State of Pennsylvania, have invented certain Improvements in the Construction of Ball Tuyere-Irons, of which the following is a specification:

The object of this improvement in ball tuyere-irons is to obviate serious objections to the manner of molding and casting the ordinary base for the forge or smith fire-hearth, as heretofore constructed, by doing away with the external lugs on the lower end of the case, as also on the sides of the frame for the door to slide in, and which is usually bolted to the bottom of the case. The reasons are herein more fully set forth.

The accompanying drawings, with the letters of reference marked thereon, and a brief explanation, will enable those skilled in the art to make and apply my invention.

Figure 1 is a side elevation of the combination; Fig. 2, a top view of the case with the ball and spindle removed, also the top or cover C. Fig. 3 shows the three-sided door-frame, and D the sliding door, with its stop P.

The only novelty in the construction of the case A is in casting an inner flange or ledge, B, on two sides, having central openings *s h*. This ledge is flush with the bottom of the case.

The three-sided frame B' is also perforated centrally, for screw-bolts to match, so that the frame can be set on to adapt it for a right or left side door.

I use headed screw-bolts, which pass through the sides of the frame and the inner side flanges of the case, to which it is secured by a nut. This frame has a shouldered or depressed ledge, so as to form an open space for the door D to slide back and forth in between it and

the under side of the ledge in the case. I have also improved the greater adaptation of the ball for a smaller blast on light work, by introducing a circular opening, *f*, from one side, to enter the beveled central slot G H at right angles thereto.

All the cases of this class of tuyere-irons heretofore made have external lugs on the outside of the lower end of the case. These cannot be cast with a core to produce the hole for the bolt, inasmuch as they form a separate piece in molding, and must be drawn out first; hence it is necessary to drill holes into lugs when cast, which requires extra labor, and when so cast these lugs are very liable to be broken off in rough handling, or in ordinary transportation, as well as in drilling. All these objections are overcome by having the inner ledge cast with the case, and by doing away with the lugs on the frame and case, and to facilitate change instead of bolting or riveting the frame to the case. The use of headed screws and nuts will be more satisfactory, so that the result in this simple change is a combination which is more easily molded and fitted up, and less liable to breaking in transportation, and greatly improves this desirable class of ball tuyere-irons so much in use.

I am not aware that such improved irons were ever before known or used; therefore,

What I claim as my improvement is—

The case A, provided with the inner lower ledge or flange B, in combination with the door-frame B', without side lugs, and door D, the whole constructed and operating as and for the purpose described.

ABRAHAM K. HERR.

Witnesses:

H. G. BOOK,  
D. K. PETERS.